

Mercedes-Benz



Owner's Manual

380 SE
500 SEL
500 SEC

1985

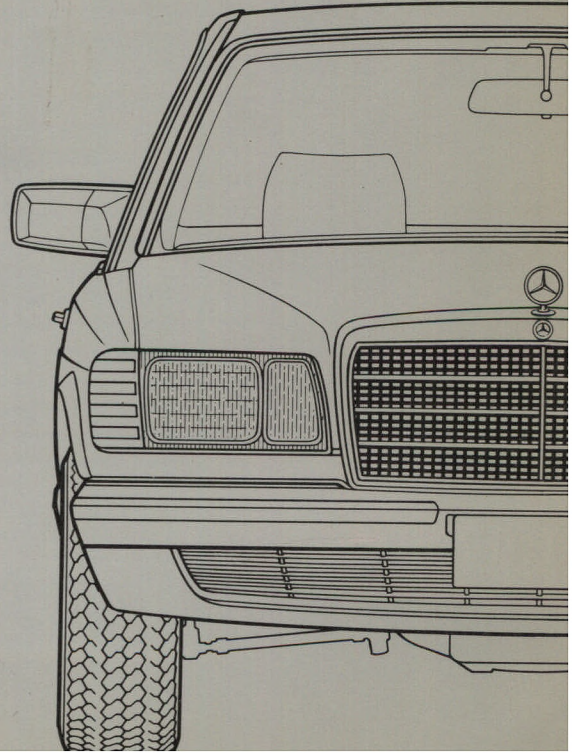

6



Drive Sensibly – Save Fuel

Fuel consumption depends to a great extent on driving habits and operating conditions.

In order to save fuel you should:

- ensure that tire pressures are correct
- not carry unnecessary loads
- remove ski racks or roof-mounted luggage racks when not in use
- not warm up your engine at idle and with the vehicle at standstill
- avoid frequent acceleration and deceleration
- have all the maintenance jobs specified by us carried out at regular intervals by an authorized MERCEDES-BENZ dealer.

Driving in low temperature weather, in stop-and-go city traffic and on short hops, and in hilly country also increases fuel consumption.

Mercedes-Benz



Owner's Manual

380 SE **500 SEL** **500 SEC**

Chassis 126

1985

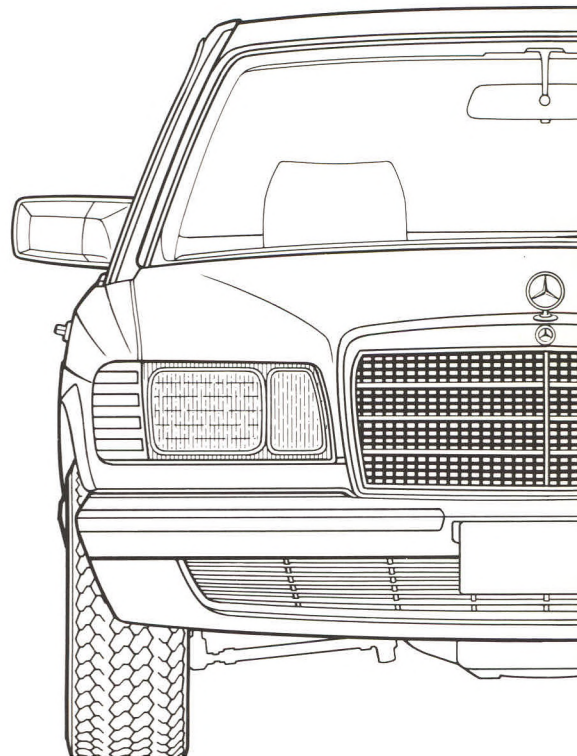

Our company and staff wish you many hours of enjoyment with your new vehicle.

You have placed a lot of trust in our company name by purchasing a MERCEDES, from which you may expect that it will give you long service with a minimum of trouble, and is easy to operate.

We have just one request to make, hoping that it will benefit you as well:

Please do not put this manual aside without first carefully reading it.

You may notice that it contains many important recommendations that should make the operation of your MERCEDES easier and even increase your pleasure driving it.

We wish you many miles of motoring pleasure.
Daimler-Benz Aktiengesellschaft

Special equipment is also described in this manual, including operating instructions wherever necessary. Since there are special-order items, the descriptions and illustrations herein may vary slightly from the actual equipment of your vehicle. If there are any equipment details that are not shown or described in this Owner's Manual, your MERCEDES-BENZ dealer will be glad to inform you of correct care and operating procedures.

Vehicle Operation		Controls	28
Instruments and Controls	10	Steering Lock	28
Instrument Cluster	12	Lighting Switch	29
Keys, Doors	14	Combination Switch	30
Master Key and		Cruise Control	31
Supplementary Key	14	Automatic Climate Control	32
Flat Key	14	Various Equipment	37
Obtaining Replacement		Exterior Mirrors	37
Keys	14	Inside Rear View Mirror	37
Opening, Locking and		Sun Visors	38
Unlocking of Doors	15	Sliding Roof	38
Central Locking System	16	Interior Lamps	39
Anti-Theft Alarm System	17	Heated Rear Window	39
Seats	18	Lighter	40
Adjusting Power Seats, Front.	18	Shelf below Rear Window.	40
Safety Head Restraints, Rear.	19	Power Windows	40
Rear Seat Adjustment		Radio	41
500 SEL.	20		
Electrical Adjustment of the			
Individual Rear Seats			
500 SEL.	20		
Orthopedic Seat Backrest	21		
Arm Rest (Front Seats).	21		
Arm Rest (Rear Seat)	22		
Seat Heater	22		
Supplemental Restraint			
System	23		
Seat Belts and Emergency			
Tensioning Retractor.	23		
Driver Airbag	26		

The last page

What you should know at the gas station

Contents

Driving

Hood	48
Parking Brake	48
Regular Inspections	49
Catalytic Converter Cautions	50
Starting and Turning off the Engine	51
Starting and Shifting Gears	52
Safe Driving	54
Brake Pad Wear Indicator Lamp	55
Brake Fluid	55
ABS-Brake System (Anti-Lock Brake System)	56
Charge Indicator Lamp	57
Fuel Reserve Warning Lamp	57
Outside Temperature Indicator	57
Oil Pressure Gauge	57
Coolant Temperature Gauge	57
Engine Oil Consumption	57
Emission Control	58
The First 1500 km/1000 Miles	58
Driving Economically	58
Economical Driving Indicator (ECONOMY)	58
Special Operating Conditions	59
Winter Driving	59
Hints for Driving	59
Tire Chains	60
Traveling Abroad	60

Vehicle Care

MERCEDES-BENZ Maintenance System	62
Spare Parts Service	63
Cleaning and Care of the Vehicle	63
Jobs related to Care	64

Practical Hints

Safety Head Restraints	68
Rear Seat Cushion	69
Ash trays	69
First Aid Kit	70
Luggage or Ski Racks	70
Spare Wheel, Jack, Vehicle Tool Kit	71
Wheels, Tires, Changing Wheels Wheels, Tires	72
Changing Wheels	73
Tire Inflation Pressure	74
Checking Fuels, Coolants, Lubricants, etc.	75
Engine Oil Level Check	75
Checking Coolant Level	76
Adding Coolant	76
Automatic Transmission Fluid Level	77

Electrical System	78	Technical Data, Fuels, Coolants, Lubricants, etc.	
Headlamp Adjustment	78	Identification Plates	88
Replacing Bulbs	78	Vehicle Data Cards	89
Fuses	82	Warranty Coverage	89
Spark Plugs	82	Technical Data.	90
Battery	83	380 SE	90
Windshield Wipers	84	500 SEL, 500 SEC.	92
Emergency Operation of		Fuels, Coolants, Lubricants, etc.	94
Sliding Roof.	84	Capacities.	94
Unlocking the Fuel Filler Flap	84	Engine Oils	96
Jump Starting.	85	Fuel Requirements	96
Tow-starting and Towing		Brake Fluid	96
the Vehicle	85	Coolants	97
		Service Literature	98
		Consumer Information	99

Vehicle Operation ▶

Driving ▶

Vehicle Care ▶

Practical Hints ▶

**Technical Data, Fuels,
Coolants, Lubricants, etc.** ▶

Vehicle Operation



Instruments and Controls

For more detailed descriptions see quoted pages.

- 1** Speaker grilles
- 2** Side ventilation outlets (page 32)
- 3** Swivelling outlets for nonheated fresh air (page 32)
- 4** Parking brake release handle (page 48)
- 5** Handle to disengage hood lock (page 48)
- 6** Parking brake pedal (page 48)
- 7** Combination switch (page 30)
- 8** Lighting switch (page 29)
- 9** Cruise control (page 31)
- 10** Instrument cluster (page 12)
- 11** Horn control
- 12** Steering lock with ignition/starter switch (page 28)
- 13** Lever for nonheated fresh air (page 32)
- 14** Switch for heated rear window (page 39)
- 15** Switch for electric sliding roof (page 38)
- 16** Switch for hazard warning flasher system
- 17** Switch for automatic antenna (page 46)
- 18** Switch for rear passenger compartment lamp (page 39)
- 19** Automatic climate control (page 32)
- 20** Radio (page 41)
- 21** Ash tray with lighter (page 40, 69)
- 22** Switch for left front seat heater (page 22)
- 23** Switch for right front seat heater (page 22)
- 24** Switch group for power windows (page 40)
- 25** Adjusting lever for exterior mirror on front passenger side (page 37)
- 26** Loudspeaker — fader control
- 27** Glove compartment, illuminated (only in steering lock positions “1” or “2”)

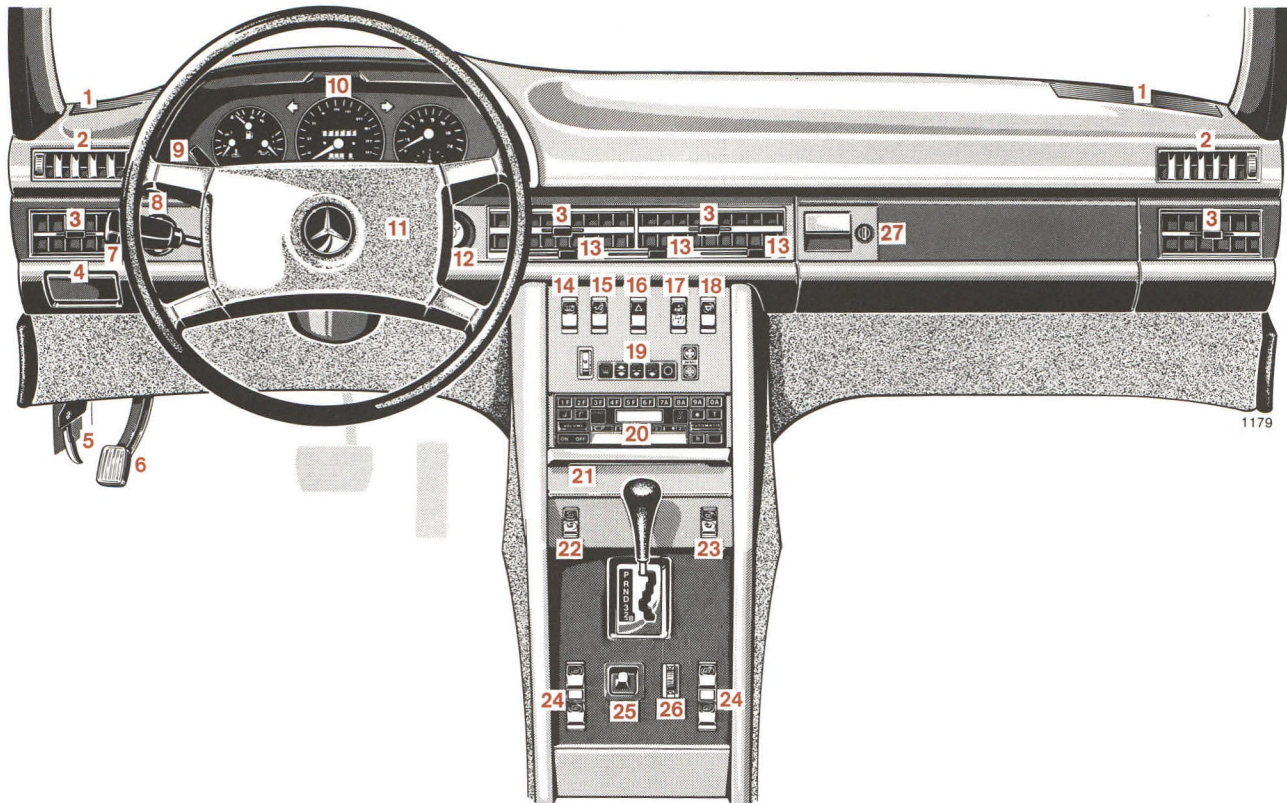

Instrument Cluster

- 1 Economical driving indicator (ECONOMY).
See page 58
- 2 Coolant temperature gauge
Up to red marking: Maximum permissible temperature for an anticorrosion/antifreeze-blended fill protecting down to $-30^{\circ}\text{C}/-22^{\circ}\text{F}$. See page 57
- 3 Fuel gauge with reserve warning lamp (yellow):
Comes on when the steering lock key is moved to driving position "2" and must go out when the engine is idling. See page 57
Fuel reserve and capacity, refer to page 95 and last page
- 4 Oil pressure gauge (bar). See page 57
- 5 Turn signal indicator lamp, left (green)
- 6 Main odometer
- 7 Trip odometer
- 8 Turn signal indicator lamp, right (green)
- 9 Tachometer
- 10 Red marking on tachometer:
Excessive engine speed
- 11 Electric clock
- 12 Knob for clock adjustment
(press in for adjustments)
- 13 O₂-Sensor replacement indicator lamp (red):
When the indicator lamp comes on, the O₂-Sensor must be replaced
- 14 Supplemental restraint system indicator lamp (red). See page 26
- 15 Seat belt warning lamp (red)
- 16 ABS indicator lamp (yellow). See page 56
- 17 Outside temperature indicator. See page 57
- 18 Brake warning lamp (red) comes on if
 - the parking brake is engaged
 - not enough brake fluid is in the reservoir
- 19 Brake pad wear indicator lamp (yellow):
Lights up during braking if the front wheel brake pads are worn down. See page 55
- 20 Charge indicator lamp (red):
Comes on when the steering lock key is moved to driving position "2" and must go out when the engine is idling. See page 57
- 21 High beam indicator lamp (blue)
- 22 Knob for instrument lamps and trip odometer
Rotate knob: instrument lamps intensity are infinitely variable
Depress knob: trip odometer is reset

Instrument Cluster

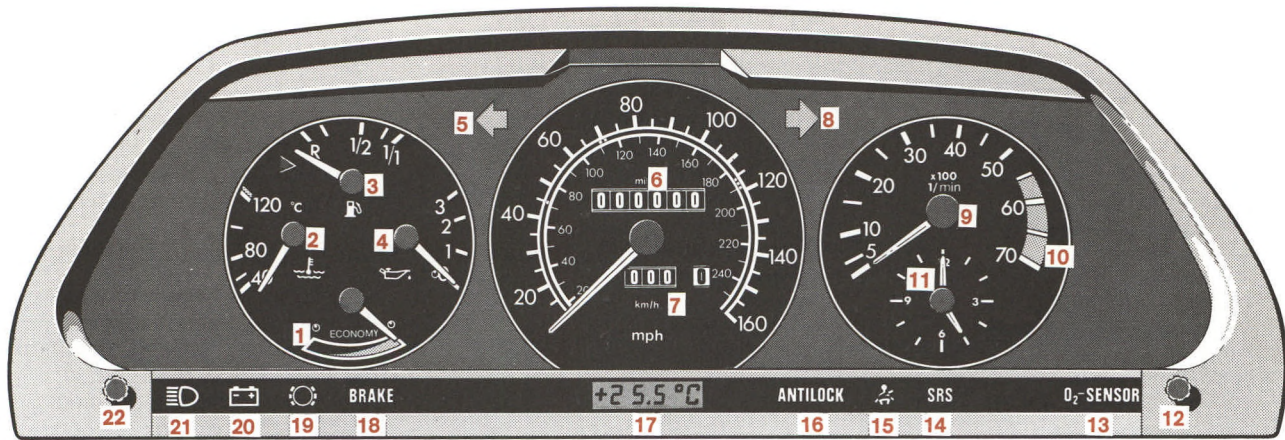

1099

Keys Doors

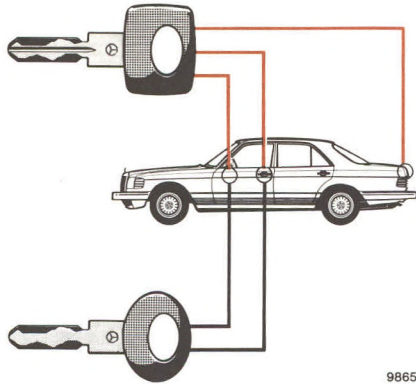

9865

Master Key – square head with a red dot – fits all locks on the car. Arms/disarms the anti-theft alarm system.

Supplementary Key – rounded head – fits only the door locks and the steering lock. This key is intended to be used whenever the car is left with an attendant. Be sure to lock glove compartment and trunk with the master key. The supplementary key cannot be used to de-activate the anti-theft alarm after the car was locked with the master key.

Flat Key



The flat key with a red dot fits all vehicle locks. Arms/disarms the anti-theft alarm system. We recommend that you carry the flat key with you and keep it in a safe place so that it is always handy, if needed (e.g. in your wallet). Never leave the flat key in the vehicle.

Obtaining Replacement Keys

You are given 4 keys with your vehicle. Replacement keys can be obtained only via an authorized MERCEDES-BENZ dealer. For security reasons, obtaining replacement keys requires considerable time.

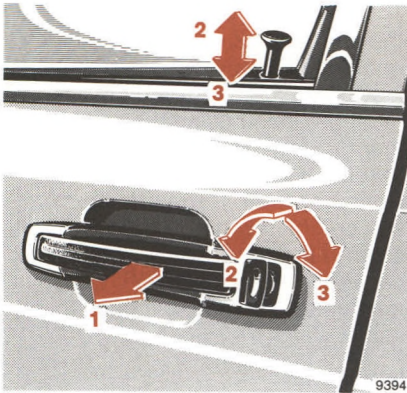

9394

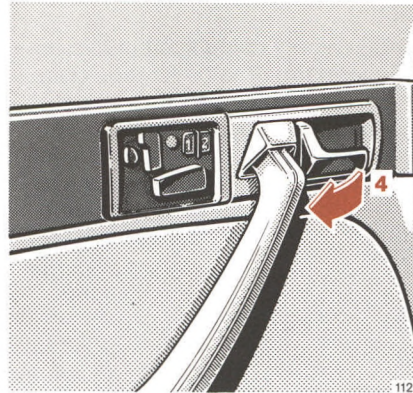

1122

Opening the Doors

From outside: pull handle outwards (1).

From inside: pull handle in door trim panel (4).

Locking and Unlocking of Doors

From the outside: turn key.

From the inside: actuate button.

- 2 Unlocking
- 3 Locking

When the rear door buttons are pushed down, the rear doors cannot be opened from the outside or the inside. They can only be opened after pulling buttons up.

The driver's door can be locked only if it is closed and the door lock has properly engaged.

Central Locking System

The entire vehicle may be locked or unlocked with the central locking system:

- Using the master key, supplementary key, or by pushing down or pulling up the interior door lock buttons at the front doors.
- From the trunk using the master key only.

The central locking system allows you to lock or unlock all doors, trunk lid and fuel filler flap simultaneously.

Doors

When you lock the car, all door lock buttons should move down. If any one stays up, the respective door was not properly closed. You should then unlock the car, open and re-close this door, and lock the car again.

Note:

The central locking system can be engaged from the driver-side door lock button, provided the door is completely closed. It can also be engaged from the passenger-side if the ignition key is removed, or engaged in the lock without being turned (key in position "0").

If the car has been locked from the outside with the master key, the anti-theft alarm will come on if a door is opened from the inside.

Trunk

To unlock the trunk with the central locking system, turn the master key in the trunk lock completely to the left and let it return to the normal position. Push in trunk lock button and open the trunk. To lock the trunk, turn the master key completely to the right and let it return to the normal position.

The trunk can remain locked while the central locking system is unlocked (e.g. while driving or when leaving the car in a situation where it must be driven using the supplementary key but you wish the trunk to remain locked at parking lots, workshops, etc.). Turn the master key completely to the right and pull it out in that position. Now the trunk can only be unlocked with the master key by turning it back to the left.

Important!

Contrary to prior model year vehicles, if the trunk is unlocked with the central locking system engaged, the doors and fuel filler flap will also be unlocked. After closing the trunk, the central locking system must again be engaged using the key!

Note:

If the fuel filler flap cannot be opened, refer to "Unlocking the Fuel Filler Flap" (page 84).

Anti-Theft Alarm System

The anti-theft alarm can be armed or disarmed with the master key (identified by red dot) by locking or unlocking either front door or the trunk.

Operation

Once the alarm system has been armed, the vehicle lamps will flash and the horn will sound intermittently when an unauthorized person tries to:

- open a door
- open the trunk
- remove the radio
- switch on or bridge the steering lock
- step on the brake pedal
- raise the vehicle, i.e. towing away.

The alarm will last approximately 150 seconds in the form of blinking exterior lamps. At the same time an additional horn will sound intermittently for 60 seconds, and repeat for another 60 seconds after a 30 second pause.

The alarm will stay on even if the arming element (a door, for example) is immediately closed.

To avoid setting off the alarm unintentionally, do not arm the alarm system in the following situations; e.g.: Auto ferry, auto train, when hitching/unhitching a trailer, or heavy loading/unloading. For this purpose use the supplementary key and not the master key for locking the vehicle.

Special Function

To activate the anti-theft alarm from the trunk, turn the master key in the trunk lock completely to the right and pull it out in this position.

If you want the alarm system to be armed at the trunk only, turn the master key in the trunk lock completely to the right and pull it out in that position. Then disarm the rest of the vehicle by unlocking either front door with the master key. You can now lock or unlock the doors and filler flap, as well as start the engine, in the usual manner using the supplementary key.

Do not give the master key to an unauthorized person. We recommend that you carry the flat key safely with you (e.g. in your wallet) so that it is always handy, if needed. This key has the same function as the master key.

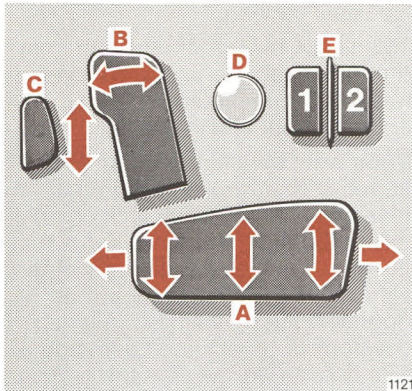

Adjusting Power Seats, Front

The switches are located in each front door.

Turn key to steering lock position "2" (with the driver's door opened, the power seats can also be operated with the key removed or in steering lock position "1" or "0").

Seat and Head Restraint Adjustment:

- A Seat cushion adjustment.
- B Seatback adjustment.
- C Head restraint adjustment. Adjust head restraint to support the back of the head approximately at ear level. The head restraint can also be turned forward by hand.

Note:

The head restraint should not be pulled up past the detent when making adjustments.

Warning!

Do not make adjustments with vehicle in motion.

Storing seat and safety head restraint positions in memory:

- D Memory button.
- E Position buttons "1" and "2".

Two sets of seat/head restraint positions may be programmed in memory. After the seat and head restraints are positioned, push memory button D, and within 3 seconds push position button "1". The second set of positions for the seat and head restraint can be stored by pushing position buttons D and "2".

Recalling seat and head restraint positions stored in memory:

To recall a seat/head restraint position, push position button "1" or "2" until seat/head restraint movement has stopped. For safety reasons, the seat/head restraint movement stops after releasing the position button.

Warning!

Do not make adjustment with vehicle in motion.

To remove head restraint refer to "Practical Hints".

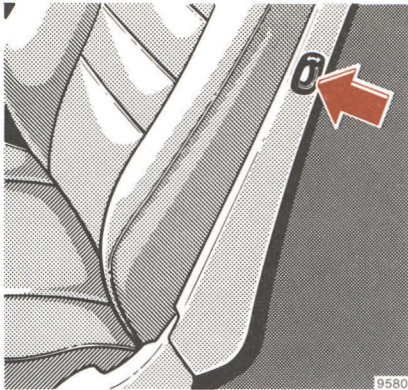

Coupé: For safety, when the doors are closed the backrests are locked by means of vacuum. The locks can be released by pushing button (arrow). When the doors are opened the backrests can be folded forward without pushing the button.

Note:

Prior to operating the vehicle, the driver should adjust the seat height for proper vision as well as fore/aft placement and seat back angle to insure adequate control, reach, operation, and comfort. The head restraint should also be adjusted for proper height so that when the cushion is tipped completely forward, it should form a cradle behind the seat occupant's head.

Both the inside and outside rear view mirrors should then be adjusted for adequate rearward vision. Fasten seat belts. Children under the age of six or under the weight of 23 kg/50 lb should be seated in the back seat with an approved restraint system properly secured.

All seat, head restraint, and rear view mirror adjustments as well as fastening of seat belts should only be accomplished before the vehicle is put into motion.

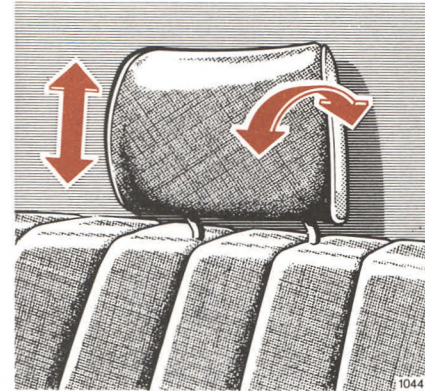

Safety Head Restraints, Rear

Adjust head restraint to support the back of the head approximately at ear level. Do not extend the head restraint past the stop.

For removal of head restraint refer to "Practical Hints".

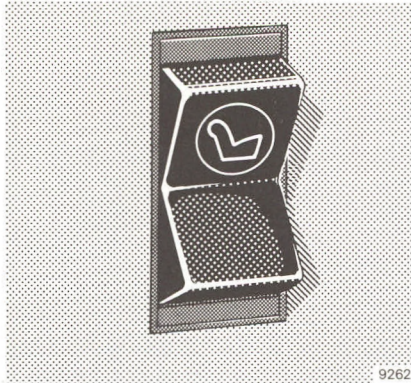

Rear Seat Adjustment 500 SEL

Move key in steering lock to position "2".

The rear seat can be adjusted in longitudinal direction using the switch located in the rear door. The inclination of the seat back is altered together with the adjustment of the seat cushion.

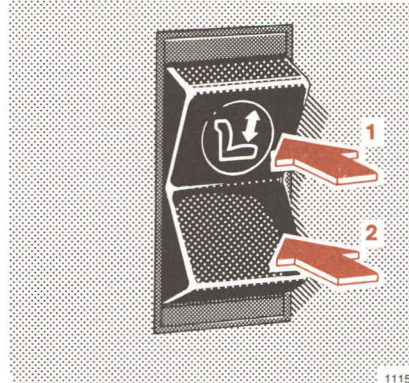

Electrical Adjustment of the Individual Rear Seats 500 SEL

The switches are located on the console between the seats.

Turn key in steering lock to position "2".

Press switches:

- 1 Upward seat cushion adjustment
- 2 Downward seat cushion adjustment
- 3 Forward seat back adjustment
- 4 Rearward seat back adjustment

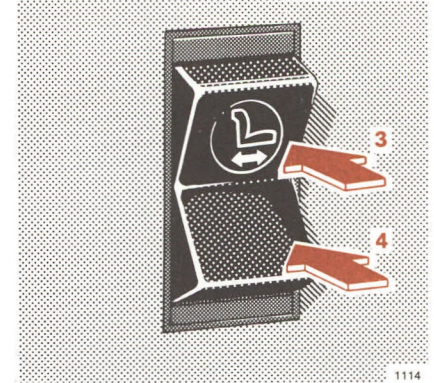

Note:

The seats can also be adjusted when the key is withdrawn or in steering lock positions "1" or "0" provided the driver's door is opened.

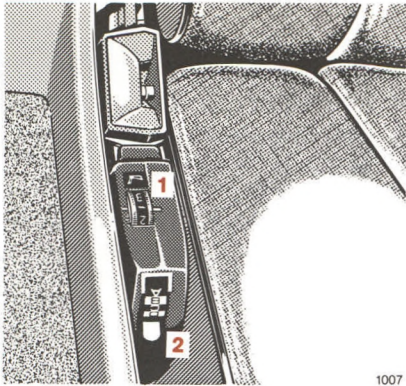

1007

The inflation pressure of the air cushion may be continuously varied between position “0” = without pressure, and position “4” = maximum pressure, by changing the pressure regulator (1) setting.

In addition, the cushion height may be changed to five different settings between position “A” = lowest setting, and “E” = highest setting, by varying the height regulator (2) adjustment.

If a driving trip is temporarily interrupted, the last cushion setting is retained in memory, and automatically adjusts the cushion to this setting when the trip is continued.

Arm Rest (Front Seats)

The arm rest engages in 3 positions.

Position 1 = arm rest folded up.

Position 2 = for normally inclined seat back.

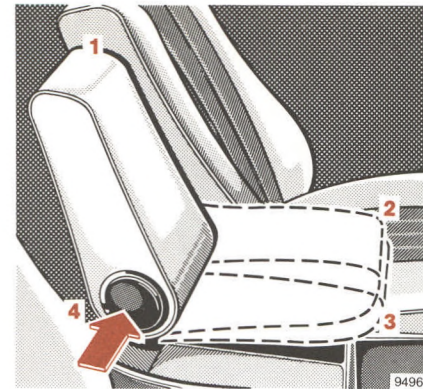

9496

Position 3 = for extremely inclined seat back.

For downward adjustment of the arm rest, depress release button 4.

Warning!

The arm rest does not suffice as a child restraint system. In case of a frontal collision a child can be catapulted forward over the locked arm rest.

Orthopedic Seat Backrest

Some models may be equipped with orthopedic seats. These seats have an inflatable air cushion built into the backrest to provide additional lumbar support. The amount of cushion height and curvature may be adjusted after turning the key in steering lock to position “2”.

Seats

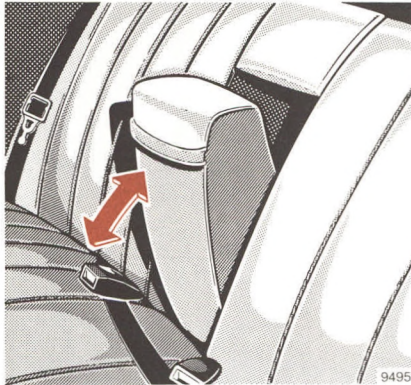

Arm Rest (Rear Seat)

An arm rest is provided in the rear seat which can be pulled out with the loop.

For the removal of the rear seat cushion see "Practical Hints".

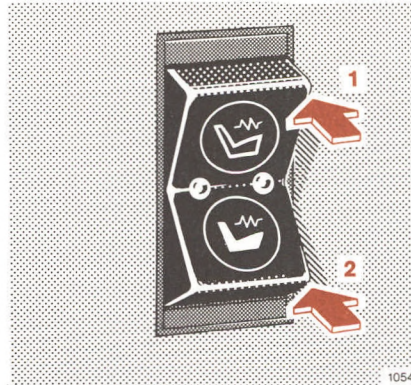

Seat Heater

The front seat heaters can be switched on with the steering lock in positions "1" or "2", the rear seat heaters only in steering lock position "2".

The switches for the front seats are located at the forward end of the center console, those for the rear seats are accommodated in the rear doors.

Heater operation:

Push in upper switch portion; position 1 = normal heater operation, one indicator lamp lights up.

Push in lower switch portion; position 2 = rapid heating, both indicator lamps light up.

After approximately 5 minutes in the rapid heating mode, the heater automatically switches to normal operation and only one indicator lamp will stay on.

Turning off heater:

If one indicator lamp is on, press in upper part of switch, position 1.

If both control lamps are on, press in lower part of switch, position 2.

The heater automatically turns off after approximately 30 minutes of operation.

Note:

When in operation, the seat heater consumes a large amount of power. It is advisable not to use the seat heater longer than necessary.

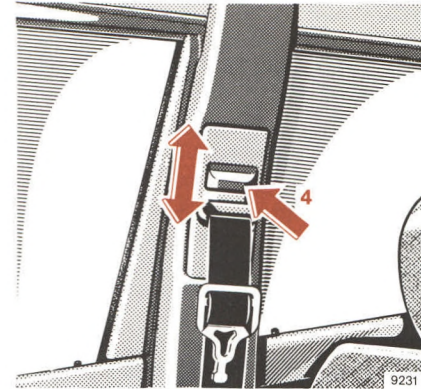
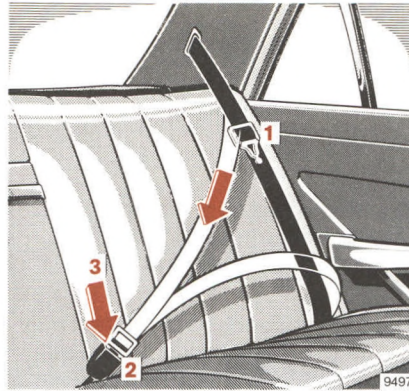

Seat Belts and Emergency Tensioning Retractor

Your vehicle is equipped with seat belt and emergency tensioning retractors for front seats. The tensioning retractors are located in each belt's inertia reel and become operationally ready with the key in steering lock position "1" or "2".

Warning system:

The indicator is illuminated for 4–8 seconds after turning the steering lock key to position "2". If the seat belt of the driver's seat is not fastened a warning buzzer sounds simultaneously.

Fastening:

- Pull belt with latch plate (1) over shoulder and lap. Do not twist the belt doing this.
- Push latch plate (1) into buckle (2) until it clicks.

- 380 SE, 500 SEL:
Adjust front seat belts so as to have the upper belt located as near as possible to the middle of the shoulder. For this purpose, push button (4) and raise or lower belt outlet (3 positions).
- 500 SEC:
When the respective door is closed and the key is in steering lock position "2", the seat belt extender brings the belt forward within easy reach of occupant. The seat belt extender returns to its rest position whenever the

Supplemental Restraint System

seat belt is buckled or when resistance to its extension is encountered (e.g., accidental occupant contact).

If the seat belt is not buckled within 30 seconds, the seat belt extender will return to its rest position.

This is also the case if the key is turned to steering lock position "1" or "0" or if the door is opened.

Emergency operation:

If the electrical system fails, the push rod together with belt can be manually pushed back into their rest position.

- The belt must be pulled snug and checked for snugness immediately after engaging it and during driving. If necessary, tighten the lap portion to a snug fit by pulling shoulder portion up.

On the coupe, the swivel fitting which is mounted on the lower anchoring point to facilitate entering the vehicle must point forward.

Unfastening:

- Push in the red button (3) in the belt buckle.
- The retractor should completely rewind the belt and latch plate (1).

Operation:

The inertia reel stops the belt from unwinding during sudden vehicle stops or when quickly pulling on the belt.

The locking function of the reel may be checked by quickly pulling out the belt.

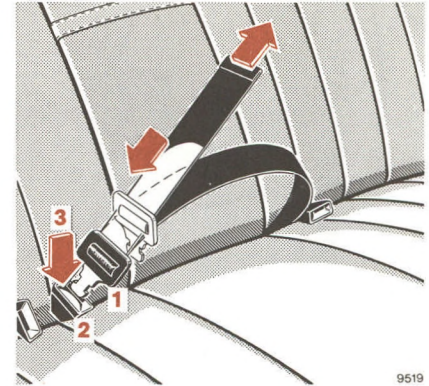

9519

Lap belt in rear passenger compartment:

Pull belt with latch plate (1) across the lap, press latch plate into buckle (2) until it clicks. The belt must not be twisted and must be tight.

To shorten the belt, pull belt end with the latch plate engaged. To lengthen the belt, turn the latch plate so that it is at a little more than 90° to the belt and pull before fastening the belt.

To disengage the belt, push red button (3) in buckle.

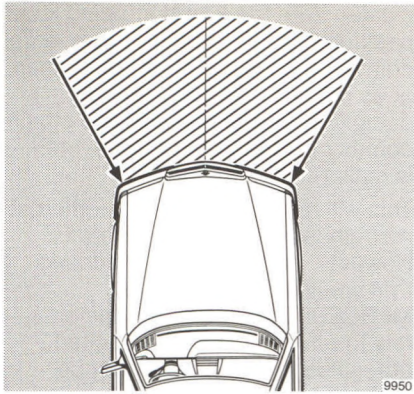

The emergency tensioning retractors are designed to activate only during severe frontal impacts. They tighten the belts in such a way that they fit more snugly against the body restricting as much as possible its forward movement.

In cases of less severe frontal impacts, such as roll-overs, side or rear collisions, or other accidents without severe frontal forces, the emergency tensioning retractors will not be activated. The driver and passengers will then be protected by the fastened seat belts and inertia reel in the usual manner.

Warning!

Rear seat passengers should always wear seat belts – for their own protection and to avoid endangering the driver and front passenger with their unrestricted forward movement.

No seat belt can be used for more than one person. Children under the age of six or under the weight of 23 kg/50 lb should be seated in the back seat with an approved restraint system properly secured.

Child restraint systems recommended by us can be fastened to the existing seat belts. Any authorized MERCEDES-BENZ dealer will gladly advise you on this subject.

For cleaning and care of the seat belts, see page 64.

For seat belt and emergency tensioning retractor safety rules, see page 27.

Supplemental Restraint System



Driver Airbag

If your vehicle is additionally equipped with a driver airbag, this can be recognized by the letters “SRS” stamped into the steering wheel hub pad and by the indicator lamp “SRS” (Supplemental Restraint System) in the instrument cluster.

The airbag (1) is located in the steering wheel hub and, in conjunction with wearing the seat belts with tensioning retractors (2), provides increased protection for the driver.

The operational readiness of the supplemental restraint system (airbag and emergency tensioning retractor) is verified by the indicator lamp “SRS” (3) in the instrument

cluster. With the key in steering lock position “1” or “2”, the indicator lamp comes on for about 10 seconds then goes out. If it doesn't come on, doesn't go out, flickers on and off, or comes on while driving, the system is malfunctioning.

This will not cause the supplemental restraint system to be activated. However, we strongly recommend that you visit an authorized MERCEDES-BENZ dealer immediately to have the system checked; otherwise the “SRS” may not be activated in a severe frontal accident.

The airbag is designed to activate only in severe frontal impacts (see illustration on page 25). Only during these types of impacts will it provide its supplemental protection. The driver should always wear the seat belt, otherwise it is not possible for the airbag to provide its intended protection.

In cases of less severe frontal impacts, such as roll-overs, side or rear collisions, or other accidents without severe frontal forces, the airbag will not be activated. The driver and other passengers will then be protected by the fastened seat belts.

The activation of the “SRS” temporarily releases a small amount of dust from the driver airbag and all of the seat belt emergency tensioning retractors. This dust, however, is neither injurious to your health, nor does it indicate a fire in the vehicle.

The service life of the airbag extends to the date indicated on the glove compartment sticker. To provide continued reliability after that date, it should be inspected by an authorized MERCEDES-BENZ dealer at that time.

Safety Guidelines for the Supplemental Restraint System – Seat Belts, Emergency Tensioning Retractor and Airbag

Damaged belts or belts that were highly stressed in an accident must be replaced and their anchoring points must also be checked. Use only belts installed or supplied by MERCEDES-BENZ.

Do not pass belts over sharp edges.

Do not make any modification that could change the effectiveness of the belts.

An airbag or tensioning retractor that was activated must be replaced.

No modifications of any kind may be made to any components or wiring of the “SRS”. This includes the installation of additional trim material, badges, etc. over the steering wheel hub and installation of additional electrical/electronic equipment on or near “SRS” components and wiring.

Improper work on the system, including incorrect installation and removal, can lead to possible injury through an uncontrolled activation of the “SRS”. In addition, through improper work there is the risk of rendering the “SRS” inoperative. Work on the “SRS” must therefore only be performed by an authorized MERCEDES-BENZ dealer.

When scrapping the airbag unit or tensioning retractor, it is mandatory to follow our safety instructions. These instructions are available at every authorized MERCEDES-BENZ dealer.

When you sell the vehicle we strongly urge you to give notice to the subsequent owner if it is equipped with an “SRS” by alerting him to the applicable section in the Owner’s Manual.

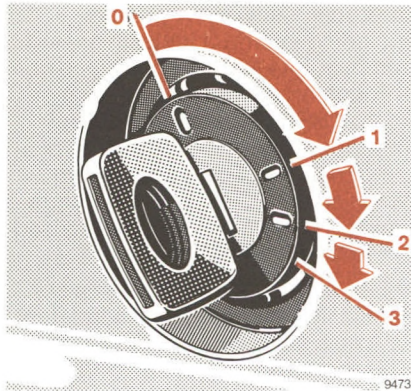

Steering Lock

- 0 Steering is locked when the key is withdrawn and the steering lock is engaged. The key can be withdrawn only in zero position.

Note:

Do not remove key from steering lock while the vehicle is in motion as this will cause the engagement of the steering lock thus rendering the vehicle inoperable.

- 1 Steering is unlocked. (If necessary, move steering wheel slightly to turn the key clockwise to position "1".)
- 2 Driving position.
- 3 Starting position.

For starting and turning off the engine, refer to page 51.

Notes:

The following items can be operated with the key in steering lock position "1":

Wipers, windshield washer, head-lamp flasher, lighter, glove compartment lamp, radio, seat heater for front seats.

A warning buzzer sounds when the key has been left in steering lock position "1" or "0" and the driver's door is opened.

With the engine at idle speed, the charging rate of the alternator (output) is limited.

It is therefore recommended to turn off unnecessary electrical consumers while driving in stop and go traffic. This precaution helps to avoid draining the battery.

An effective measure to preserve battery power is to turn off the following consumers:

Seat heater, heated rear window.

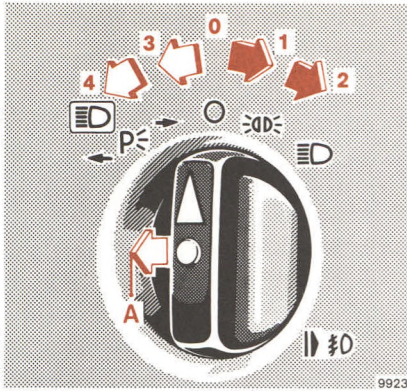

Lighting Switch

- 0 Off-position
- 1 Parking lamps (includes side marker lamps, tail lamps, license plate lamps, instrument panel lamps)
- 2 Same as pos. 1 plus headlamps
- 3 Standing lamps, right
- 4 Standing lamps, left
- A Turn to position 2 and pull out to first detent = same as position 2 plus fog lamps

Notes:

With the steering lock key removed and the driver's door open, a warning buzzer sounds if the vehicle's exterior lamps are not switched off (standing lamps excepted).

Fog lamps will only operate together with low beam headlamps. Fog lamps are turned off automatically when lighting switch is returned to off-position.

Controls

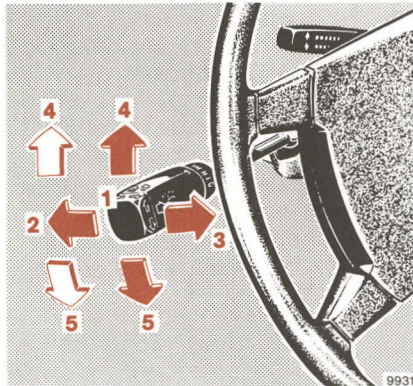

Combination Switch

- 1 Low beam (with lighting switch turned clockwise two notches)
- 2 High beam (with lighting switch turned clockwise two notches)
- 3 High beam flasher (high beam available independent of lighting switch position)
- 4 Turn signals, right
- 5 Turn signals, left

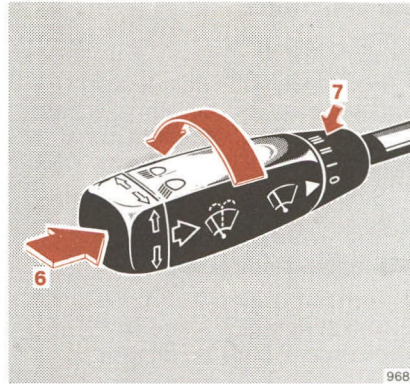

- 6 Control for windshield washer system
When the washer system is switched on, the wipers also operate.
- 7 Windshield wiper control
0 Windshield wiper switched off
I Intermittent wiping
II Normal wiper speed
III High wiper speed

Hints:

If one of the turn signals fails, the turn signal indicator system flashes and sounds at a faster sequence than under normal operating conditions.

For the overload protection for the windshield wiper motor, see page 84.

To operate the turn signals, move the combination switch past the point of resistance (up or down). The switch is automatically cancelled when the steering wheel is turned by a large enough angle.

To signal minor directional changes of the vehicle, such as changing lanes on a highway, move combination switch to the point of resistance only and hold it there.

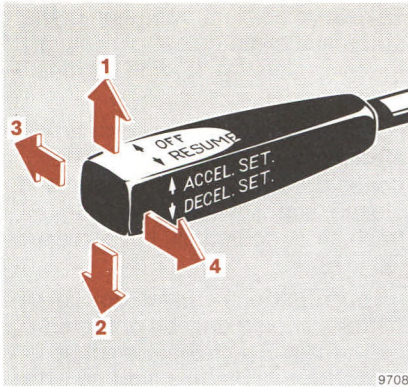

Cruise Control

Any given speed above approximately 40 km/h/25 mph can be maintained with the cruise control by operating the switch.

- 1 Setting (briefly push switch)
Accelerating (hold switch)
- 2 Setting (briefly push switch)
Decelerating (hold switch)

Normally the vehicle is accelerated to the desired speed with the accelerator. Speed is set by briefly pushing the switch to position 1 or 2. The accelerator can then be released.

The speed can be increased (e. g. for passing) by using the accelerator. As soon as the accelerator is released, the previously set speed will be resumed automatically.

If a set speed is to be increased or decreased slightly, e. g. to adapt to the traffic flow, hold switch in position 1 or 2 until the desired speed is reached. When the switch is released, the newly set speed remains.

- 3 Cancelling
To cancel the cruise control, briefly push lever to position 3.
When you step on the brake pedal or the vehicle speed falls below approx. 40 km/h/25 mph, for example when driving upgrade, the cruise control will be cancelled.
- 4 Resume
If the lever is briefly pushed to position 4 when driving at a speed exceeding approximately 40 km/h/25 mph, the vehicle resumes the speed which was set prior to the cancellation of the cruise control. The last

memorized speed is cancelled when the key in the steering lock is turned to position "1" or "0".

Note:

If the engine does not brake the vehicle sufficiently while driving on a downgrade, the speed you set on the cruise control may be exceeded and you may have to step on the brake pedal to slow down. As soon as the grade eases, the cruise controlled speed will again be maintained as long as the brakes were not previously applied.

Important:

Only use the cruise control if the traffic conditions make it advisable to travel at a steady speed.

Position "Resume" should be engaged only if the driver is fully aware of the previously set speed and wishes to resume this particular preset speed.

When driving with the cruise control, the transmission selector lever must not be shifted to position "N" as otherwise the engine will overrev.

Automatic Climate Control

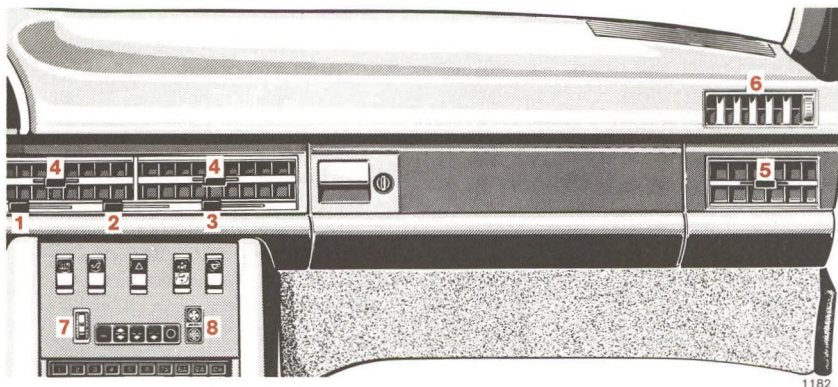

For proper operation of the climate control system, keep all windows and the sliding roof closed.

The engine must be running for the ACC unit to work.

Heating, cooling and air distribution within the vehicle's interior will be automatically controlled. Furthermore, settings are available for extreme weather conditions, enabling the defogging of the windshield or air ventilation to top and bottom.



This is accomplished with the temperature selector (7), the push buttons, and the fan switch (8).

The air outlets (4), (5) and (6) can be opened, closed or moved as desired. The movable outlets (5) can be opened and closed with levers (1) and (3), and outlets (4) with lever (2). Levers towards left = open. Outlets (6) can be variably opened and closed by turning of control wheel. Wheel turned up = open.

To ensure efficient operation of the automatic climate control system, the air outlets (4), (5) and (6) must be kept open.

For the rear passenger compartment, a movable air outlet in the console, which can be opened and closed, supplies either non-heated, fresh air or cooled air. Lever towards left = open.

All push buttons and fan control buttons should only be operated individually. The indicator lamps in the individual buttons light up when pressed with the lighting switch in position 1 or 2.

We strongly recommend settings  and  only, in connection with the desired fan setting. The following instructions explain the remaining settings.

Temperature Selection (° C)

The interior temperature can be adjusted by turning the temperature selector wheel. The selected temperature is reached as quickly as possible and maintained. A basic setting of 22° C/72° F is recommended. In order to avoid undesirable temperature fluctuations, a set temperature should be readjusted in small increments.

To override the automatic climate control, turn the temperature selector wheel to either extreme end position “MAX” or “MIN”.

“MIN” = Peak cooling performance: the system operates mostly with recirculated air and a small amount of fresh air is added. If the fan control is set to “AUTOM”, it will run continuously in speed No. 5.

“MAX” = Maximum heating performance. If the blower control is set to “AUTOM”, it will run continuously in speed No. 5.

Fan Setting

 Selection for fan settings can be made as follows:

 Push upper button for maximum fan speed (6th speed).

Push lower button for minimum fan speed (1st speed).

Push middle button (spring loaded) for automatic control of air supply within 2nd through 5th fan speed range.

Setting  = Always maximum fan speed.

Functions

Off

In this setting, the fresh air supply to the interior of the car is shut off, (to prevent entrance of odors, i.e., while driving through tunnels, etc., or to prevent the entrance of water from automatic car washes). Use this setting only temporarily while driving.

Automatic Climate Control

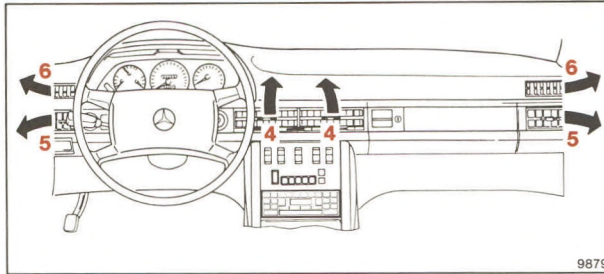

 Economy setting – Ventilation

 Normal setting – Cooling

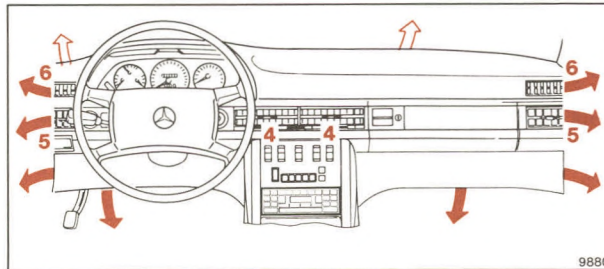

 Economy setting – Heating

 Normal setting – Heating

 EC (ECONOMY) = Economical setting; the air conditioning compressor stays off.

In any other settings, the air conditioning compressor comes on with ambient temperatures above +2° C/36° F.

We recommend this setting to be used with cool outside temperatures, so the air conditioning compressor stays off in order to save fuel.



In the blower operation, air is emitted from outlets (4), (5) and (6) only.

In the heating mode, air is primarily supplied to the foot area. In addition, air is also supplied to the front doors. Only enough air is supplied to the windshield and air outlets (5) and (6), in order to keep the glass defogged in normal weather conditions. In the heating mode, air will be emitted periodically from outlet (4).

With cold outside temperatures, the fresh air supply and the fan remain turned off until the engine coolant has warmed up slightly.

 Normal Setting

We recommend this setting with humid and warm outside temperatures.

The setting  corresponds with setting  but, in addition, the air can be cooled or heated as necessary.

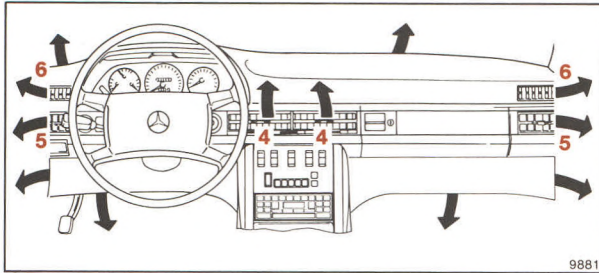

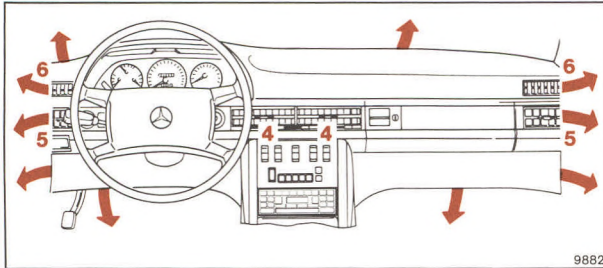

 Multi-Level ventilation – Cooling



 Multi-Level ventilation – Heating

Multi-Level

This setting is necessary for clearing a fogged windshield. As soon as possible, reset to  or .

In the heating mode, air is supplied to the windshield, foot area, air outlets (5) and (6), and the front doors – in the cooling mode, additionally to air outlet (4). In the heating mode, warm air will be emitted periodically from outlet (4).

Automatic Climate Control

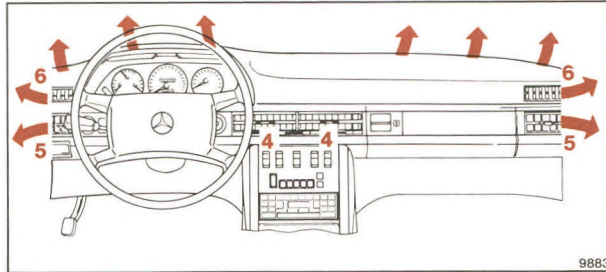

Defrosting

Defrosting

The maximum amount of heated air is directed to the windshield and side windows, regardless of temperature and fan speed setting.

Note:

The air conditioner removes considerable moisture from the air during operation. It is normal if water drips on the ground through openings in the car floor.

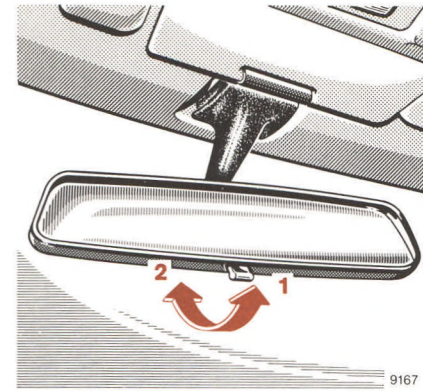
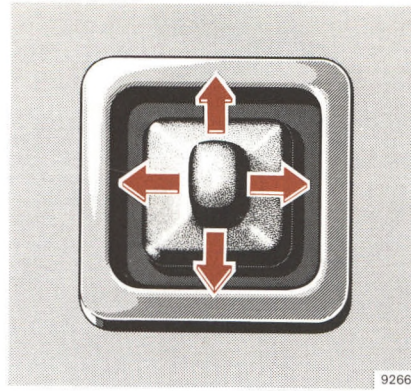
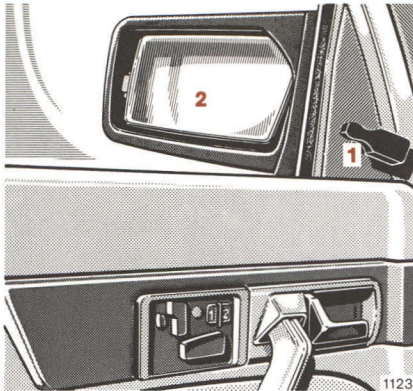

Exterior Mirrors

Driver's side:

The exterior mirror (2) can be adjusted from inside the vehicle by moving adjusting lever (1) in the desired direction.

Passenger side:

Turn key in steering lock to position "2". The exterior mirror can be adjusted by means of the switch.

Note:

If the mirror housing has been forcibly moved from its normal position, it must be repositioned by applying firm pressure.

Inside Rear View Mirror

The mirror can be tilted to the anti-glare night position by means of the lever at its lower edge.

1 = Normal position

2 = Anti-glare night position.

Various Equipment

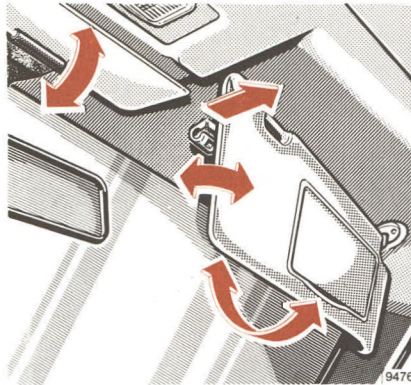

Sun Visors

Swing sun visors down to protect against sun glare.

If sunlight enters through the side window, disengage visor from inner mounting and swing to the side.

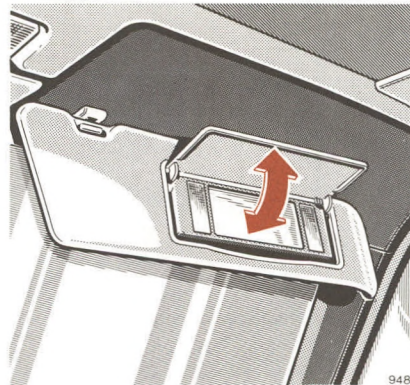

Vanity mirror:

Swing down sun visor. The lamps are switched on when the cover is opened. For this purpose the visor must be engaged in its inner mounting.

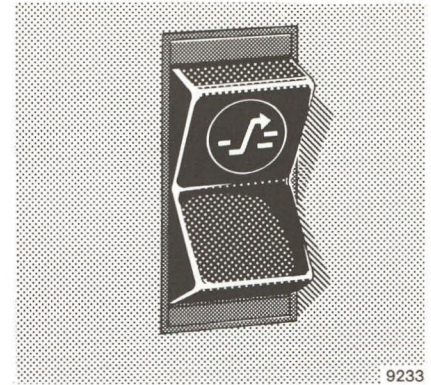

Sliding Roof

Turn key in steering lock to position "2".

Press upper end (symbol) of rocker switch to open roof, press lower end to close.

If the electric drive fails, the sliding roof can also be moved by hand. Refer to "Emergency Operation of Sliding Roof" (page 84).

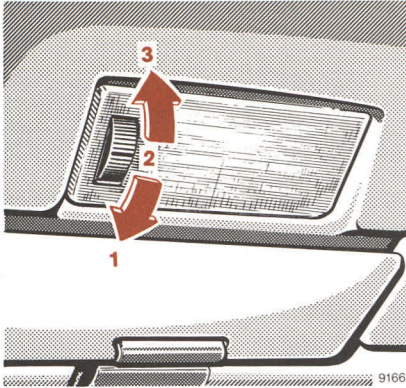

Interior Lamps

The switch for the front lamp has 3 positions.

Position 1: the lamp is switched on and off (delayed) by the front door contact switches.

Position 2: lamp switched off permanently.

Position 3: lamp switched on permanently.

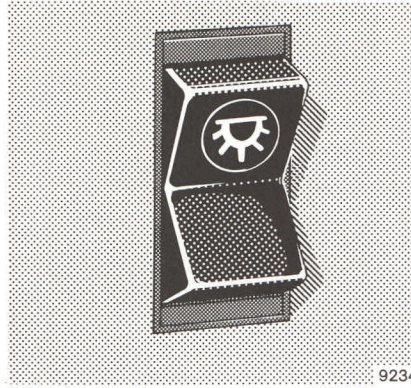

The rear courtesy lamp is switched on and off by the rear door contact switches or by the rocker switch on the instrument panel.

The reading lamps in the rear passenger compartment are switched on and off by means of a switch in each lamp.

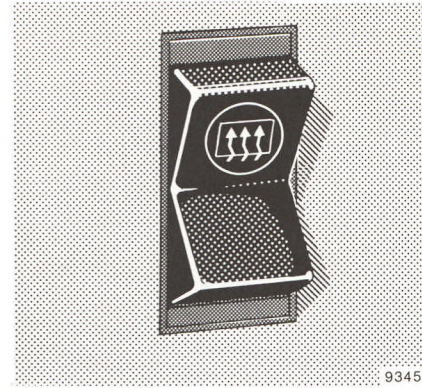

Heated Rear Window

With the engine running, press symbol side of rocker switch to turn on, bottom to turn off.

When the rear window heater is turned on, the indicator lamp in the switch comes on.

A heavy load is imposed on the battery due to the high power requirement. For this reason, switch off the heated rear window as soon as it is demisted or defrosted. It is shut off automatically after a maximum of 20 minutes. Remove snow or ice from window before starting to drive.

Various Equipment

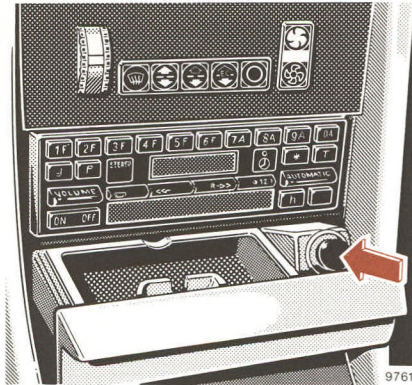

Lighter

Turn key in steering lock to position “1” or “2”.

Press in lighter; it will pop out automatically when hot.

Shelf below Rear Window

The shelf below the rear window should not be used to carry objects. This will prevent such objects from being thrown about and injuring vehicle occupants during an accident or sudden maneuver.

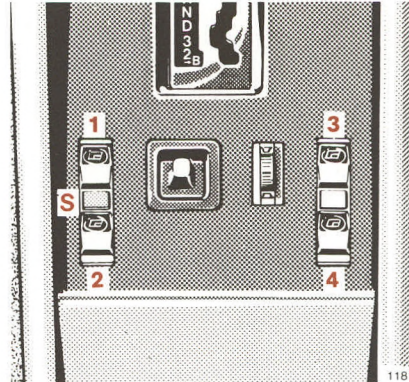

Power Windows

Switch group for power windows:

- 1 front, left
- 2 rear, left
- 3 front, right
- 4 rear, right
- S Safety switch

The power windows can only be operated with the steering lock in position “2”. All four windows can

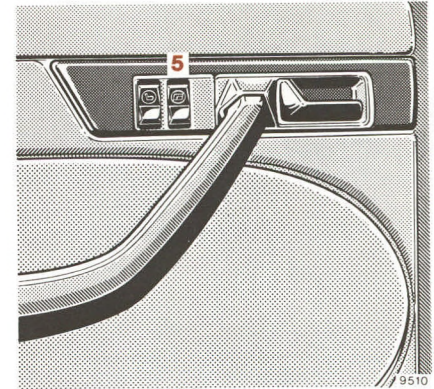

then be operated using the switches in the center console. The rear door windows can also be operated using the switches (5) in each rear door panel as long as the safety switch “S” in the center console is depressed. If the safety switch is not depressed, inadvertent operation of the rear door windows (for instance, by children) is prevented.

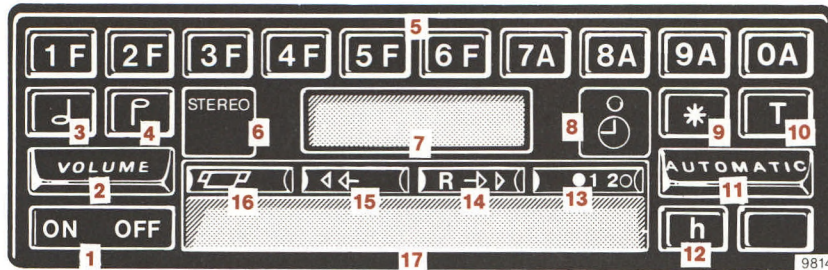

Electronic Radio

- 1 On/Off switch **ON OFF**
- 2 Volume control **VOLUME**
- 3 Bass control **B**
- 4 Treble control **T**
- 5 Push buttons for AM/FM band selection, station frequency selection, station presetting and clock setting **1F** through **0A**
- 6 Stereo indicator lamp **STEREO**
- 7 Digital display for station frequency, station push button number, AM/FM band 07:30 and time display
- 8 Recessed button for setting time **Ⓢ**
- 9 Function control button *****
- 10 Timer button to control switch-on time of radio **T**
- 11 Automatic or manual search station seeker bar **AUTOMATIC**
- 12 Time display button **h**
- 13 Cassette track selector switch and track indicator **1 2 0**
- 14 Fast tape rewind locking button **R → P**
- 15 Fast tape forward locking button **← F**
- 16 Cassette eject button **EJECT**
- 17 Cassette door

15 Fast tape forward locking button **← F**

16 Cassette eject button **EJECT**

17 Cassette door

To turn the radio on or off, the steering lock key must be in position "1" or "2".

To turn the radio ON

Press "ON" side of **ON OFF** switch. The radio will begin operating on the last station, volume and tone setting stored before the last turn off. The radio can also be turned on by inserting a tape cassette through the cassette door.

To turn the radio OFF

Press the "OFF" side of the **ON OFF** switch.

Volume adjustment

To reduce volume, press volume switch **VOLUME** downward; to increase volume, press volume switch **VOLUME** upward.

Radio

A fader control, installed in the center console, allows for balancing the sound level between the front and rear speakers.

To adjust the tone characteristic

To set the radio to a “flat” tone setting (bass and treble at mid-range setting), briefly press both tone controls **B** **T** simultaneously.

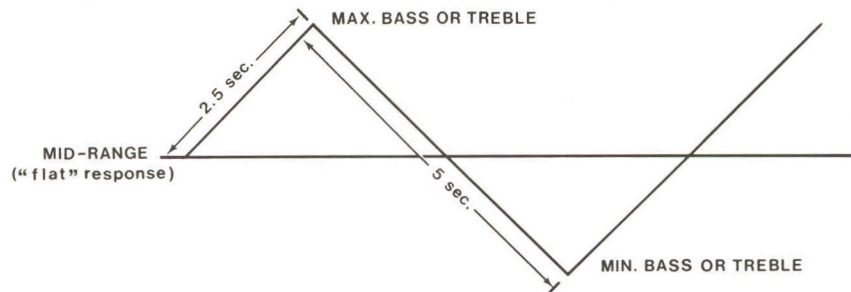

Upon pressing either tone button, the tone level for that function (either bass **B** or treble **T**) will begin increasing. It stops increasing when the button is released or when the maximum tone level is reached (approx. 2.5 seconds). After reaching the maximum tone level, the tone control will stay at that level unless the tone button is released and pressed again.

Once the tone button is pressed again the tone level will start decreasing. It will stop decreasing when the button is released or when the minimum tone level is reached (approx. 5 seconds).

After reaching the minimum tone level, the tone control will stay at that level unless the tone button is released and pressed again. After pressing the tone button again the tone level will begin to increase and the cycle is repeated.

Note: It takes approx. 5 seconds to go from minimum tone level to maximum tone level.

To select AM or FM

Press any of the buttons marked **1F** through **6F** to tune the radio to the FM band.

Press any of the buttons marked **7A** through **0A** to tune the radio to the AM band.

To tune to a station

Stations can be tuned in by using automatic search, direct frequency dialing, manual tuning, or by preset push buttons. The frequency of the station selected is indicated on the digital display.

Automatic station search

Switch to the wave band desired by pressing any of the following buttons: for FM, buttons **1F** through **6F**, for AM, buttons **7A** through **0A**.

By pressing the automatic station seeker bar **AUTOMATIC** upward the radio will search for stations in ascending frequencies, by pressing down it will do so in descending frequencies. The direction of automatic searching can be reversed by pressing the bar **AUTOMATIC** in the respective direction. In order to arrive at a desired station without stopping, the bar has to be held in the desired direction.

The radio is programmed to automatically search the entire band at three sensitivity levels. During its first sweep, only the most powerful stations received will be selected and locked in. During the next sweep, the less powerful and during the third sweep, the weak stations will also be locked in.

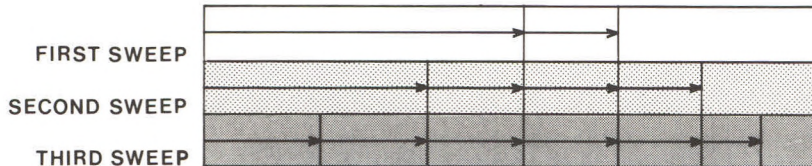

If the station seeker bar is activated within 8 seconds after the radio is tuned to a station, then the search operation will be continued at the same sensitivity level. If 8 seconds are exceeded, the radio will revert to searching only the most powerful stations.

Direct frequency dialing

In order to select a station with a known frequency, select the wave band, press the function button ***** and then enter the frequency by pressing the corresponding push buttons.

Example:

	FM 98.5 MHz	AM 1050 KHz
Press any button marked	1 F through 6 F	7 A through 0 A
Press the function button	*	*
Enter frequency by pressing	9 A , 8 A , 5 F	1 F , 0 A , 5 F , 0 A

When dialing a frequency directly, the number of the push buttons is not displayed on the panel. The wave band is indicated by showing "MHz" for FM or "KHz" for AM.

Note:

All AM stations have allocated frequencies ending with a "0". All FM stations have allocated frequencies ending with an odd (uneven) digit after the decimal point. Broadcasters sometimes may not give their exact frequency but the next closest even number.

US radio frequency ranges:
AM 540 – 1600 KHz
FM 88.1 – 107.9 MHz

Manual tuning (used to fine tune a station or for manual scanning)

After selecting the desired AM or FM wave band, press the function control button *****.

Press automatic station seeker bar **AUTOMATIC** (up or down) and hold. The frequency will increase or decrease respectively in increments of 0.1 MHz for FM or 1.0 KHz for AM. Release the button when the desired station is tuned in.

Unless the automatic station seeker bar **AUTOMATIC** is activated within 8 seconds after pressing the function control button *****, the manual tuning will automatically be deactivated.

Safety Note

To avoid distraction from the vehicle's operation and the road, it is recommended that the driver NOT perform any manual tuning operations while the vehicle is in motion. Use the automatic station search operation or preset stations instead.

Push button tuning

Six FM stations and four AM stations can be stored in memory and recalled by pressing the appropriate buttons marked **1F** through **6F** for FM or **7A** through **0A** for AM stations.

To store stations in memory

Any FM station frequency indicated on the digital display can be stored on any button marked **1F** through **6F** by depressing the button desired and holding it until the display has changed from the "old" setting to a "blank" and then to the new frequency to be stored.

Showing the "old" setting first allows for reconsideration of the decision to store. If it is desirable to leave the "old" frequency in memory rather than exchanging it with the "new" one, quickly release the button. The "old" frequency will remain in memory.

Any AM station can be stored similarly on any button marked **7A** through **0A**.

Stereo reception

The stereo indicator symbol **STEREO** lights up if a stereo program is received.

The radio is equipped with an automatic stereo/mono switch that electronically switches to mono for clear reception if a weak signal is received. A special circuit provides for a smooth change-over rather than a hard sudden switching, thereby reducing noise and interference.

The stereo indicator will remain lit even if the receiver has changed to the mono mode and will turn off at an antenna signal considered insufficient to provide acceptable reception quality.

Important! Although FM is normally static free, reception can be limited by geographic and atmospheric conditions, station strength and distance from transmitter. Buildings or other obstructions can cause momentary static, flutter or station swapping. If good reception cannot be obtained, tune to a stronger station.

Tape Cassette playback

It is recommended to use only good quality cassettes with a playback time of not more than 60 to 90 minutes (C 60) or (C 90).

To start playback, insert a cassette (tape side first, side "1" or "A" facing up) through the cassette door. Push the cassette in until it is locked in its playing position.

When the end of one playing side is reached, the unit switches automatically to reverse for playing the second track.

The tape track can be selected by depressing the cassette track switch button **T 20**. The built-in indicators show which track of the cassette the unit is playing back.

To stop playback, press the eject button **EJECT**. The unit will automatically eject the cassette and switch to radio reception.

For fast tape rewind press the fast rewind button **R ←**. The button will lock into position until the end of the tape is reached or until the eject **EJECT** or fast forward **F →** button is activated.

Accordingly, for fast forward on the tape, press the fast forward button .

When the radio is turned off by pressing the “OFF” side of the **ON OFF** switch or by turning the steering lock key to the off, the cassette will automatically be ejected.

Care and maintenance

To avoid deterioration of the tone quality, occasionally clean the tape head with the special cleaner supplied in your glove compartment or available through your dealer.

To set clock

Turn steering lock key to position “1” or “2”.

Briefly press recessed time set button  by using a pencil or ball-point pen.

Enter the time at which you want to start the clock by sequentially pressing four of the top row push buttons **1F** through **0A**. The time entered will be displayed.

Note: This is a 24 hour clock and time must be entered in all four digits. A 24 hour clock counts time

from midnight to midnight, that is 24 hours. A time of 4:28 PM is indicated by this clock as 16:28 hours (12 plus 4:28 hours).

Example 1: To enter 7:30 AM, press buttons **0A**, **7A**, **3F**, **0A**

Example 2: To enter 4:28 PM, press buttons **1F**, **6F**, **2F**, **8A**

The time entered is now stored. To start the clock in accordance with a time signal or other time reference, again briefly press the recessed time set button .

A colon sign will appear between the second and third digits **07:30**, to indicate that the clock is activated.

With the radio switched off, the time will be indicated on the digital display. When the radio is switched on, the digital display will indicate the frequency which the radio is tuned to.

To display time

Briefly press the call button **h**. The time will be displayed for a few seconds.

To use the timer **T**

By using the timer **T**, the radio can be automatically turned on at a preset

time. In order to set the timer **T**, the steering lock key must be in position “1” or “2”. The timer **T** can only turn the radio on with the steering lock key in position “1” or “2”.

Setting the timer

1. Press button **T**.
2. Enter the time for automatic turn-on by sequentially pressing four of the top row push buttons **1F** through **0A** for the 24-hour time desired.
3. Press button ***** to activate the timer. Activation of the timer is indicated by a colon between the second and third digits of the time.

Note: To activate this function each day, press buttons **T** and ***** with the key in steering lock position “1” or “2”. The radio will then turn on at the preset time.

Whenever you wish to verify the time at which the timer is set, press button **T**. The time will be indicated in the digital display. After a few seconds, the display will switch back to the station frequency. To change the timer to a new setting, repeat steps 1 through 3.

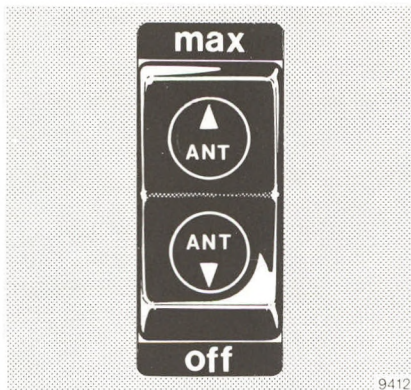

Automatic Antenna

The antenna switch can be actuated with the radio switched on and the key in steering lock positions "1" or "2".

- If the antenna switch is in the center position, the antenna extends automatically to medium height,
- if the antenna switch is engaged in the "max." position, the antenna extends fully,
- if the antenna switch is engaged in the "off" position, the antenna will not extend or will retract completely.

The height of the antenna can be adjusted to any intermediate position by actuating the antenna switch:

- If the antenna switch is in the center position, the antenna will extend to medium height. The antenna can be further extended or retracted to any height by rocking the switch (not engaging it).
- If the antenna is to be retracted, e.g. for playing cassettes, engage switch in "off" position.

When the key is turned to steering lock position "0" or the radio is turned off, the antenna will retract completely.

Driving



Hood

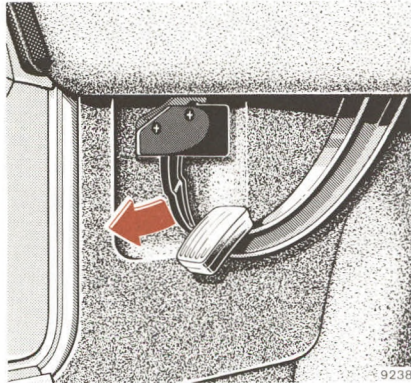

To open, pull hood release handle located on the LH side below the instrument panel. The hood opens up to the safety catch stop.

Push in safety catches on LH and RH sides of the radiator grille simultaneously and lift up hood.

To close, push hood down firmly.

Warning!

Stay clear of moving parts when the hood is open and the engine is running.

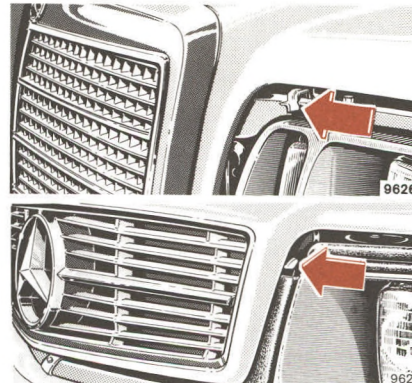

Warning!

The engine is equipped with a transistorized ignition system. Because of the high voltage it is dangerous to touch any components (ignition coil, distributor, spark plug sockets, ignition cables, diagnostic socket) of the ignition system

- if the ignition is "on" and the engine revved manually
- while starting the engine
- with running engine.

Parking Brake

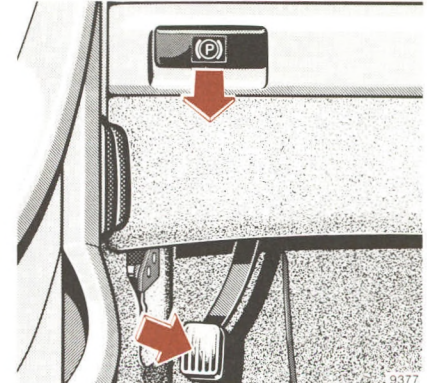

Depress parking brake pedal. When the key is in position "2" of the steering lock, the brake warning lamp in the instrument cluster comes on.

To release the parking brake, pull handle on instrument panel. The parking brake is released instantaneously. The brake warning lamp in the instrument cluster must go out.

Have the following items checked regularly and prior to any long trip

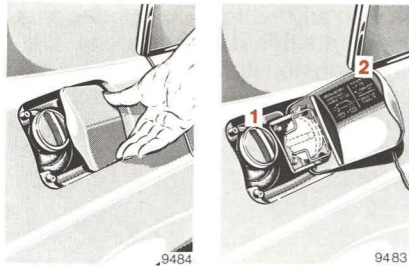

1 Fuel Supply

Use unleaded gasoline, for octane rating see “Capacities” and last page.

2 Tire Pressure

For tire pressure table refer to fuel filler flap or last page. Check at least every other week. For more details see “Wheels, Tires, Changing Wheels”.

3 Oil/Fluid Level: Engine, Automatic Transmission

See “Checking Fuels, Coolants, Lubricants, etc.”, “Fuels, Coolants, Lubricants, etc.” and last page.

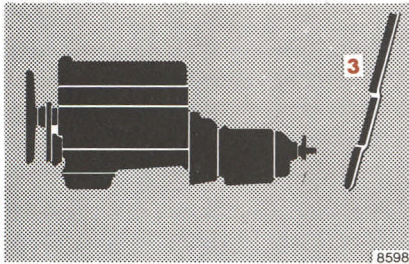

4 Coolant Level

See “Checking Fuels, Coolants, Lubricants, etc.”, “Fuels, Coolants, Lubricants, etc.” and last page.

5 Brake Fluid

When the minimum mark on the reservoir is reached, have the system checked (brake lining thickness, leaks).

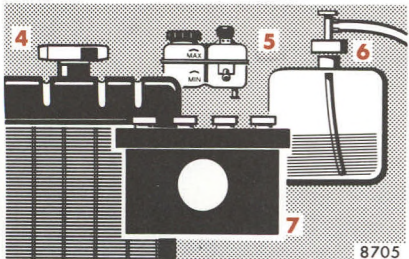

6 Windshield Washer

Replenish with windshield washer solvent (container is in the engine compartment). Add MB auto shampoo, see page 64.

7 Battery

Replenish with distilled water only. See “Electrical System”.

Vehicle Lighting

Check for function and cleanliness.

Catalytic Converter Cautions



Your MERCEDES-BENZ is equipped with monolithic catalytic converters, an important element in conjunction with the O₂-sensor to achieve substantial control of the pollutants in the exhaust emissions. Keep your vehicle in proper operating condition by following our recommended maintenance instructions as outlined in your maintenance booklet.

Should any noticeable irregularities in the engine operation occur, excessive unburned fuel may reach the converter causing it to overheat. For the same reason we caution against refueling with leaded gasoline.

As with any vehicle, do not idle, park or operate this vehicle in areas where combustible materials such as grass, hay or leaves can come into contact with a hot exhaust system, as these materials could be ignited.

Engage parking brake and move the gear selector lever in either “P” or “N” position before starting the engine.

Turn key in steering lock to position “2”. The charge indicator lamp must come on.

Cold Engine

Turn key in steering lock clockwise to the stop. Do not depress accelerator. Release key only when the engine is firing regularly.

At ambient temperatures of less than $-18^{\circ}\text{C}/0^{\circ}\text{F}$, depress accelerator three times prior to starting.

Hot Engine

Turn key in steering lock clockwise to the stop. Do not depress accelerator. If the engine has not fired after approx. 4 seconds, depress accelerator and continue cranking until the engine is firing regularly. Release key and back off accelerator.

Turning off

Turn the key in the steering lock to position “0” and only remove the key when the vehicle is at standstill. If the coolant temperature is very high (e.g. after hard driving on mountain roads), do not shut off the engine immediately, allow it to run for 1 – 2 minutes at increased idle speed.

Hints

Due to the installed starter non-repeat unit, the key in the steering lock must be returned to “0” position before a new starting attempt is made.

Observe the oil pressure gauge immediately after starting the engine. In a very cold engine the oil pressure will only rise slowly, some time after the engine has started. Do not speed up the engine before pressure is registered on the pressure gauge.

The charge indicator lamp must go out as soon as the engine has started.

Should too much fuel have entered the engine due to several unsuccessful starting attempts and the engine will no longer fire, depress the accelerator while starting. In this way the mixture becomes combustible again. Back off the accelerator only when the engine is firing regularly.

In areas where temperatures frequently drop below $-25^{\circ}\text{C}/-13^{\circ}\text{F}$, we recommend that a block heater is installed. Every MERCEDES-BENZ dealer will advise you on this subject.

Starting and Shifting Gears

The automatic transmission simplifies the handling of the vehicle. The individual gears are shifted automatically dependent upon selector lever position, vehicle speed and accelerator position.

Hints

When parking the vehicle or if working on the vehicle with the engine running, depress parking brake pedal and move selector lever to position “P”.

Warning!

Keep driver’s foot area clear at all times. Objects stored in this area may cause impairment of pedal movement.

Driving

Shift selector lever to the desired driving position only when the engine is idling and the service brake is applied. Do not release the brake until ready to drive. The vehicle may otherwise start creeping when the selector lever is in a driving position.

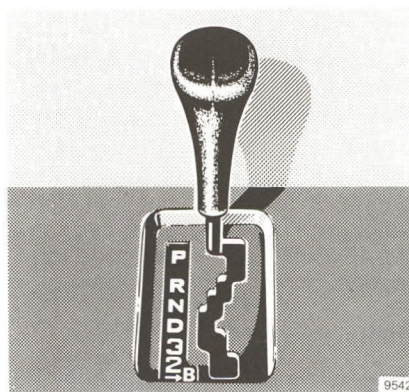

Test the service brake shortly after driving off.

Warm up the engine smoothly. Do not place full load on the engine until the operating temperature has been reached.

When taking off on a slippery surface, do not allow one driving wheel to spin for an extended period.

Accelerator position

Partial throttle = early upshifting = normal acceleration.

Full throttle = later upshifting = maximum acceleration.

Depressing the accelerator beyond full throttle to kickdown position means downshifting to the next lower gear and thus maximum acceleration. If you ease up on the accelerator after having attained the desired speed, the transmission will shift up again.

Selector Lever Positions

The automatic gear shifting process can be adapted to specific operating conditions by means of the selector lever.

- “P” Parking lock.
The parking lock is an additional safeguard when parking the vehicle. Engage only with the car stopped.
- “R” Reverse gear.
Shift reverse gear only with the car stopped.

- “N” Neutral.
No power is transmitted from the engine to the rear axle. When the brakes are released, the vehicle can be moved freely (pushed, towed or tow-started). Do not engage “N” when driving except when the vehicle is in danger of skidding (e.g. on icy roads, see page 59).
- “D” Drive.
380 SE:
Automatic upshifting to top gear. The vehicle starts off in 1st gear. Position “D” affords optimum driving characteristics under all normal operating conditions.
- 500 SEL, 500 SEC:
Automatic upshifting to top gear. 1st gear can be engaged only by means of kickdown. Position “D” affords optimum driving characteristics under all normal operating conditions.
- “3” Upshift to 3rd gear only. Suitable for medium range up or downgrades.

- “2” Upshift to 2nd gear only.
For driving in mountainous regions. Since transmission will not shift up further, this gear selection will make use of the engine’s braking power.
- “B” In this position, the engine’s braking effect is utilized while descending steep or lengthy downgrades, especially with a trailer. Use this position only below 60 km/h/40 mph.

Important!

Do not exceed the speed limits for individual gear selections, which are correspondingly indicated by marks on the speedometer.

Do not attempt downshifting to a lower gear unless the speedometer needle is below the speed-limit-mark of that particular gear range. Over-revving could result in damage to the engine.

On slippery road surfaces, it is not recommended to downshift in order to obtain braking action.

Trailer Operation

When proceeding on a hill, do not allow the engine RPM to drop too low. Shift the gear selector well in advance, depending on the degree of incline or decline, to position “3” or “2”.

Stopping

When stopping, e.g. at a traffic light, hold vehicle with service brake while leaving the transmission engaged; do not hold vehicle by accelerating the engine. This will help to avoid unnecessary heat build-up in transmission.

For longer stops with the engine idling, shift into “N” or “P”.

Maneuvering

To maneuver in tight areas, e.g. when pulling into a parking space, control the car speed by gradually releasing the service brake. Accelerate gently and do not pump the accelerator. To rock a car out of soft ground (mud or snow), alternately shift from forward to reverse, while applying partial throttle.

Safe Driving

Power assistance:

When the engine is not running, both the service brake and the steering are without power assistance. Under these circumstances, a much greater effort is necessary to steer or stop the vehicle.

Tires:

Do not allow your tires to wear down too far. With less than appr. 3 mm/ 1/8 in of tread, the antiskid properties on a wet road fall off sharply.

Depending upon the weather and/or road pavement, the traction varies widely.

Specified tire pressures must be maintained. This applies particularly if the tires are subjected to high loads (e.g. high speeds, heavy loads, high ambient temperatures).

Aquaplaning:

Depending on the depth of the water layer on the road, aquaplaning may occur, even at low speeds. Avoid track grooves in the road and apply brakes cautiously in the rain.

Tire friction:

A given speed at which a vehicle driven on dry roads can still be fully controlled must be reduced when the same vehicle is to be driven safely on a wet or icy road.

You should pay particular attention to the condition of the road as soon as the prevailing temperatures fall close to the freezing point.

If ice has formed on the road, tire traction will be substantially reduced. Under such weather conditions, drive, steer and brake particularly carefully.

We recommend M + S radial-ply tires for the cold season. On packed snow, they can reduce your stopping distance as compared with summer tires. Stopping distance, however, is nevertheless considerably greater than when the road is wet or dry.

Brakes:

When driving down long and steep declines, relieve the brakes by shifting into "B", "3" or "2". This prevents overheating of the brakes and reduces brake pad wear.

After hard braking it is advisable to drive on for some time so the air stream will cool down the brakes faster.

When driving in heavy rain for some time without applying the brakes, the first braking action may be somewhat reduced and increased pedal pressure may be necessary. For this reason, stay further away from vehicle in front.

The condition of the parking brake system is checked each time the car is in the shop for maintenance.

Between maintenance checks it is a good practice to apply the parking brake once or twice while driving at approximately 50 km/h/30 mph on a dry road. Apply brake lightly until a slight drag on the wheels is felt. Keep applying brakes for about 10 seconds while pulling release handle out, then release parking brake completely. This practice will keep the parking brake at maximum efficiency.

Warning!

The stop lamps will not come on when applying the parking brake only. Apply parking brake only when road behind vehicle is clear of traffic.

All checks and maintenance work on the brake system should be carried out by a MERCEDES-BENZ dealer.

If the parking brake is released and the brake warning lamp in the instrument cluster stays on, the brake fluid level in the reservoir is too low.

Brake pad wear or a leak in the system may be the reason for low brake fluid in the reservoir.

Have the brake system inspected at an authorized MERCEDES-BENZ dealer without delay.

Install only brake pads recommended by us. If other than recommended brake pads are installed, the braking properties of the vehicle can be affected to an extent that the safety is substantially impaired.

Brake Pad Wear Indicator Lamp

The brake pad wear indicator lamp in the instrument cluster comes on when the key in the steering lock is turned to position "2" and it must go out when the engine is running. If the indicator lamp lights up during braking, this shows that the front wheel brake pads are worn.

Have the brake system checked at an authorized MERCEDES-BENZ dealer as soon as possible.

Brake Fluid

Brake fluid should be changed once a year, preferably in spring.

Only use brake fluid recommended by us. For further information, refer to "Fuels, Coolants, Lubricants, etc."

The low brake fluid indicator lamp will come on if insufficient brake fluid is in the reservoir. (The key must be in steering lock position "2", and the parking brake released.)

When the minimum mark on the reservoir is reached, have the system checked (brake lining thickness, leaks).

ABS – Brake System (Anti-Lock Brake System)

You can tell if your vehicle is equipped with an ABS by the yellow indicator lamp with the letters “ANTILOCK” in the instrument cluster (see page 12).

The ABS prevents the wheels from locking up above a speed of approx. 3 km/h/2 mph independent of road surface conditions. It is necessary, however, that a speed of approx. 8 km/h/5 mph has been exceeded at least once after start-up.

At the instant one of the wheels is about to lock up, you will notice a slight vibration in the brake pedal and the vehicle, indicating that the ABS is enhancing the driver's ability to control the vehicle by preventing the wheels from locking. This also indicates that the ABS is in the regulating mode.

On slippery road surfaces, the ABS will already respond with a slight brake pedal pressure. The pulsating brake pedal can be an indication of hazardous road conditions, and you may want to take extra care driving.

Warning!

Always keep a safe distance from the vehicle in front of you. Only a safe, attentive and skillful driver can prevent accidents. The ABS cannot prevent accidents including those resulting from excessive speed in turns or following a vehicle too closely.

The ABS indicator lamp in the instrument cluster comes on with the key in steering lock position “2” and should go out with the engine running.

If the charging voltage falls below 10 volts, the indicator lamp comes on and the ABS is switched off. When the voltage is above this value again, the indicator lamp should go out and the ABS will be operational.

If the ABS indicator lamp does not go out, it indicates that the ABS has detected a malfunction and has switched off. In this case, the brake system functions in the usual manner, but without anti-lock assistance. We recommend that you visit an authorized MERCEDES-BENZ dealer as soon as possible to have the system checked.

Charge Indicator Lamp

Should the charge indicator lamp fail to come on prior to starting when the key is in steering lock position “2” or should it fail to go out after starting or during operation, this indicates a fault which must be repaired at an authorized MERCEDES-BENZ dealer as soon as possible.

Fuel Reserve Warning Lamp

The fuel reserve warning lamp will come on when the key in the steering lock is turned to position “2”, and will go out after the engine is running.

If the warning lamp stays on after the engine starts, or comes on while driving, it indicates that the fuel level is down to the reserve quantity.

Outside Temperature Indicator

The temperature sensor is attached to the front bumper behind the license plate base plate. Due to its location, the sensor can be affected by road or engine heat during idling or slow driving. This means that the accuracy of the displayed temperature can only be verified by comparison to a thermometer located next to the sensor, not by comparison to external displays (i.e., bank signs, etc.).

Oil Pressure Gauge

The oil pressure at idle speed may drop to 0.3 bar/4.4 psi if the engine is at operating temperature. This will not jeopardize its operational reliability. Pressure must, however, rise immediately upon acceleration.

The oil pressure gauge will not provide early warning of low oil level. Therefore, check oil level at regular intervals with the dipstick.

Coolant Temperature Gauge

If the antifreeze mixture is good to $-30^{\circ}\text{C}/-22^{\circ}\text{F}$, the boiling point of the coolant in the pressurized cooling system of your vehicle is approx. $125^{\circ}\text{C}/257^{\circ}\text{F}$ (see also “Fuels, Coolants, Lubricants, etc.”).

During severe operating conditions and stop-and-go city traffic, the coolant temperature must not rise above the red marking.

Engine Oil Consumption

Engine oil consumption can only be determined after a certain mileage has been covered. During the break-in period, higher oil consumption may be noticed and is normal.

Safe Driving

Emission Control

Certain systems of the engine serve to keep the toxic components of the exhaust gases within permissible limits required by law. (Nevertheless, we urgently advise you not to let the engine run in a closed garage.)

These systems, of course, will function properly only when maintained strictly according to factory specifications. Any adjustments on the engine should, therefore, be carried out only by qualified MERCEDES-BENZ technicians. The adjustments of the engine should not be altered in any way. Moreover, the specified service and maintenance jobs must be carried out regularly according to MERCEDES-BENZ servicing requirements. For details refer to the Maintenance Booklet.

The First 1500 km/ 1000 Miles

The more cautiously you treat your engine during the break-in period, the more satisfied you will be with its performance later on. Therefore, drive your vehicle during the first 1500 km/1000 miles at moderate vehicle and engine speeds.

During this period, avoid heavy loads (full throttle driving) and high RPMs (no more than $\frac{2}{3}$ of maximum permissible speed in each gear).

Avoid accelerating by kickdown. It is not recommended to brake the vehicle by manually shifting to a lower gear. We recommend to select positions "3" or "2" only at moderate speeds (for hill driving).

After 1500 km/1000 miles speeds may gradually be increased to the permissible maximum.

Driving Economically

Economical Driving Indicator (ECONOMY)

The indicator shows the fuel consumption tendency during various driving modes.

High fuel consumption is indicated if the pointer moves into the red area; economical driving is indicated when it is in the black area. The indications should only be compared within the same gear.

Do not compare fuel consumption readings between different gears. The following rule applies: If you drive at equal speeds, the fuel consumption is lower in the higher gear, although in this gear the pointer indicates mostly more in the red area.

Winter Driving

Have your car winterized at an authorized MERCEDES-BENZ dealer before the onset of winter.

- Engine oil change: If “year-round” multigrade engine oil is not used, be sure to use an SAE grade based on ambient temperature. For recommended engine oil viscosities refer to “Fuels, Coolants, Lubricants, etc.” and last page.
- Anticorrosion/antifreeze in the coolant: Check anticorrosion/antifreeze protection periodically. For capacity refer to “Fuels, Coolants, Lubricants, etc.”.
- Additive in the windshield washer system: Add windshield washer solvent to the water in the windshield washer system.
- Test battery: Battery capacity drops with decreasing ambient temperature. A well charged battery ensures that the engine can always be started, even at low ambient temperatures.

- Tires: We recommend M + S radial tires on all wheels for the winter season. Observe permissible maximum speed for M + S radial tires and the legal speed limit.

Hints for Driving

The most important rule for slippery or icy roads is to drive sensibly and to avoid abrupt acceleration, braking and steering action. Do not use the cruise control system under such conditions.

When the vehicle is in danger of skidding, move selector lever to position “N”. Try to keep the vehicle under control by corrective steering action.

Provided the traffic conditions will allow, only brake in a way that the wheels are locked for no more than fractions of a second as otherwise the steerability of the vehicle is lost.

Road salts and chemicals can adversely affect braking efficiency. Increased pedal force may become necessary to produce the normal brake effect. We therefore recommend depressing the brake pedal repeatedly when traveling on salt-strewn roads at length. This can bring road salt impaired braking efficiency back to normal. A prerequisite is, however, that this is possible without endangering other drivers on the road.

If the vehicle is parked after being driven on salt treated roads, the braking efficiency should be tested as soon as possible after driving is resumed while adhering to the safety requirements.

Special Operating Conditions

Tire Chains

Use only tire chains that are tested and recommended by us. Any authorized MERCEDES-BENZ dealer will be glad to advise you on this subject.

Chains should only be used on the rear wheels. Adhere to the manufacturer's mounting instructions.

After driving a short distance retighten the mounted chains.

Tire chains should only be driven on snow at speeds not to exceed 50 km/h/30 mph. Remove chains as soon as possible when driving on roads without snow.

Traveling Abroad

Abroad, there is a widely-spread MERCEDES-BENZ service network at your disposal. If you travel into areas which are not listed in the index of your dealer directory, you should request pertinent information from your dealer.

Vehicle Care



A maintenance booklet is delivered with your car listing all the maintenance jobs that must be carried out after the following mileages:

Routine Maintenance

Inspection at
1300–1600 km/800–1000 miles
Lubrication Service every
12 000 km/7500 miles
Maintenance Service every
24 000 km/15 000 miles
Additional Work every
48 000 km/30 000 miles

In the case of low mileage operation, the Maintenance Service must be carried out at least once every 2 years.

Engine Oil and Filter Change

Required every 12 000 km/7500 miles, or at least once a year when using year-round multigrade oil; otherwise at least twice a year (spring and fall).

For engine oil recommendations, see page 94.

Severe Operating Conditions

In the case of severe operating conditions or heavy use mainly in city traffic or over short distances, frequent mountain driving, poor roads, dusty and muddy conditions, trailer operation, hard and sporty driving etc., it may be necessary to carry out maintenance work at shorter than normal intervals, as follows:

Engine: Oil change with filter change every 6000 km/3750 miles

Automatic transmission: Fluid change without filter change every 24 000 km/15 000 miles

Tires: Inspect

Air cleaner: Clean or replaced element

Special Maintenance Measures

Brake fluid should be replaced annually, preferably in the spring.

It is recommended to use only brake fluid approved by MERCEDES-BENZ.

The coolant should be checked for sufficient protection before the start of and during the cold season. Have the coolant (water/anticorrosion/antifreeze mixture) replaced at least every three years (see “Fuels, Coolants, Lubricants, etc.”).

Maintenance Vouchers

Your authorized MERCEDES-BENZ dealer will certify in the maintenance booklet that all lubrication and maintenance services have been carried out at the correct intervals.

Stickers to remind you when the next lubrication service or maintenance service is due, or when the brake fluid must be changed, are provided in the middle of the maintenance booklet.

Sticker attaching points

In the frame of the driver's door:
Lubrication service and maintenance service

In the engine compartment:
Brake fluid change.

Spare Parts Service

All MERCEDES-BENZ dealers maintain a stock of original spare parts required for maintenance and repair work. In addition, strategically located parts distribution centers provide quick and reliable parts service. More than 200 000 different spare parts, even for older models, are available.

MERCEDES-BENZ original spare parts are subjected to most severe quality inspections. Each part has been specifically developed, manufactured or selected for and adapted to MERCEDES-BENZ vehicles.

Therefore, MERCEDES-BENZ original spare parts should be installed.

Cleaning and Care of the Vehicle

In operation, your vehicle is subjected to a great amount of varying external influences which, if gone unchecked, can attack the paintwork as well as the underbody and cause lasting damage.

Such damage is caused not only by extreme and varying climatic conditions, but also by air pollution, road salt, tar, gravel and stone chipping. Grease and oil, fuel, coolant, brake fluid, bird droppings, tree resins, etc. should immediately be removed to avoid paint damage. Frequent washing, however, reduces and/or eliminates the aggressiveness and potency of the above adverse influences.

More frequent washings are necessary to deal with unfavorable conditions; for example, near the ocean, in industrial areas (smoke, exhaust emissions), or during winter operation.

You should check your vehicle from time to time for stone chipping or other damage. Any damage should be repaired as soon as possible to prevent the start of corrosion.

In doing so, do not neglect the underside of the car. A prerequisite for a thorough check is a washing of the underbody followed by a thorough inspection. Damaged areas need to be re-undercoated.

Your vehicle has been treated at the factory with a wax-base rustproofing in the body cavities which will last for the lifetime of the vehicle. Post-production treatment is neither necessary nor recommended by MERCEDES-BENZ because of the possibility of incompatibility between materials used in the production process and others applied later.

After every engine cleaning you should have the engine compartment re-rustproofed. Before rustproofing, all control linkage bushings have to be lubricated with hydraulic oil (check with your local MERCEDES-BENZ dealership for recommended brands).

We have selected car-care products and compiled recommendations which are specially matched to our vehicles and which always reflect

Cleaning and Care of the Vehicle

the newest in technological standing. You can obtain MB car-care products at every MERCEDES-BENZ dealer.

Scratches, corrosive deposits, corrosion or damage due to negligent or incorrect care cannot always be removed with the car-care products recommended here. In such cases it is best to seek aid at your authorized MERCEDES-BENZ dealer.

The following topics deal with the cleaning and care of your vehicle and give important “how-to” information as well as references to recommended MB car-care products.

Car Washing

Before washing your vehicle, remove insect residues. The car should not be washed in the sun. Use only a mild car wash detergent, such as MB auto shampoo.

Thoroughly spray the car with a diffused jet of water. Direct only a very weak spray towards the ventilation intake. Use plenty of water and rinse

the sponge and chamois frequently. Rinse with clear water and thoroughly wipe dry with a chamois.

If the vehicle has been run through an automatic car wash — in particular one of the older installations — rewipe the recessed sections provided in the tail lamps (for improved prevention of soiling) if necessary. No solvents (fuels, thinners etc.) must be used.

In the winter, thoroughly remove all traces of road salt as soon as possible.

When washing the underbody, do not forget to clean the inner sides of the wheels.

Tar Stains

Quickly remove tar stains before they dry and become more difficult to remove.

Window Cleaning, Wiper Blades

Use a window cleaning solution on very dirty or oil-stained windows. Clean windshield wiper blades with

a clean cloth and detergent solution. Replace blades at least once or twice a year.

To assist with the removal of accumulated road film on the windshield and improve wiping ability, a cap of MB auto shampoo can be added to the 5 liter container of washer solvent.

Plastic Parts, Headliner and Rubber Parts

Do not use oil or wax on these parts.

Seat Belts

The webbing must not be treated with chemical cleaning agents. Use only clear, lukewarm water and soap. Do not dry the webbing at temperatures above 80° C/176° F or in direct sunlight. Never bleach or re-dye the webbing.

Steering Wheel, Instrument Cluster and Selector Lever

Use a gentle dish-washing detergent or mild detergent for delicate fabrics as a washing solution. Wipe with a cloth moistened in lukewarm solution. Do not use scouring agents.

Upholstery

Leather: Wipe leather upholstery with a damp cloth and dry thoroughly. Exercise particular care when cleaning perforated leather as its underside should not become wet.

Velours: Pressure marks resulting from dampness and heat may appear to be stains. Such marks can be removed by wiping with a moistened brush, ironing with a wet cloth or by treating with a dry shampoo. Do not sit on damp upholstery. Quick drying is achieved by applying hot air — for example, by using a hair dryer. If in doubt, please consult your authorized MERCEDES-BENZ dealer.

Using aftermarket seat covers or wearing clothing that have the tendency to give off coloring (e.g. when wet, etc.) may cause the upholstery (velour for example) to become permanently discolored. By lining the seats with a proper intermediate cover, contact-discoloration will be prevented.

Paintwork

Do not apply wax if your car is parked in the sun or if the hood is still hot. For maximum protection, the paintwork should be waxed approximately once every three months. Use the appropriate MERCEDES-BENZ Touch-Up Stick for quick and provisional repairs of minor paint damage.

Light Alloy Wheels

If possible, clean wheels once a week with lukewarm water and auto-shampoo. Use an ample supply of water.

To remove stubborn marks, use polish or paint cleaner and apply with buffing cloth or a soft cloth.

Ornamental Moldings (Chrome-Plated, Aluminium)

For regular cleaning and care of very dirty chrome-plated parts, use a chrome cleaner.



Practical Hints



Practical Hints

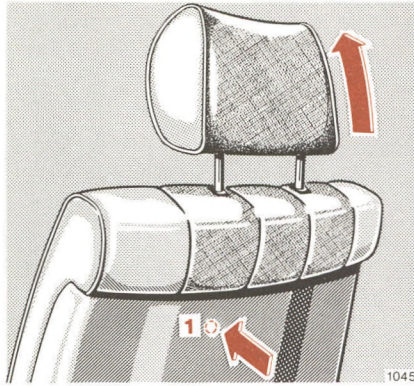

Safety Head Restraints

Removing head restraints of front seats:

Bring the power adjustable head restraint to its highest position.

Depress release button (1) to be felt under the seatback covering material and pull head restraint up sharply, holding it by the left head restraint post (viewed in driving direction). Then pull out head restraint completely with both hands.

The release button (1) is located below the left head restraint post on both front seats.

Removing rear seat head restraints:
Pull head restraint up until detent is felt. Then pull it out sharply using both hands.

Installing head restraints:

Insert the head restraint and push it down.

With power head restraint it may be necessary to first push up adjustment switch for 5 seconds.

Head restraint may now be adjusted as desired.

Note:

For your protection, drive only with properly positioned head restraints.

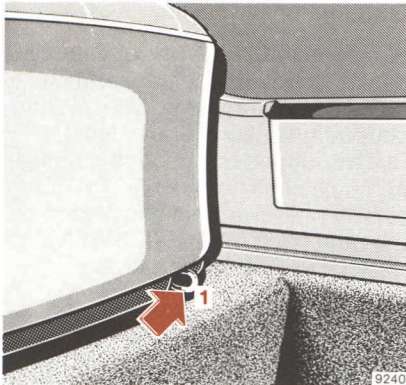

380 SE

Rear Seat Cushion

Removal: Press unlocking buttons 1 (left and right) outwards while slightly lifting the front corner of the seat cushion (do this carefully to avoid injury). Then pull the seat cushion forward.

Installation: Push rear of seat cushion under seat back as far as it will go and press down on the front section until it engages.

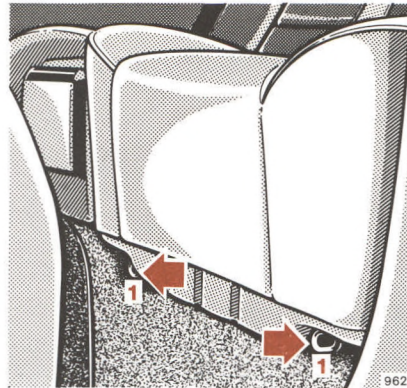

500 SEC

Note:

On vehicles with adjustable rear seats, the rear seat cushion can best be removed and installed by an authorized MERCEDES-BENZ dealer.

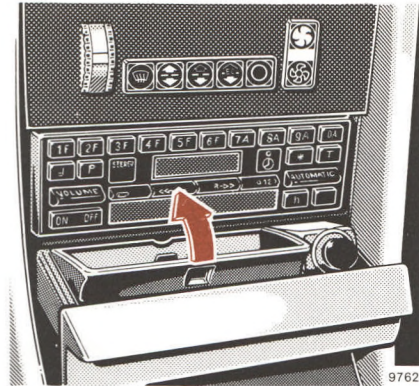

Ash trays

Removal, front:
Pull ash tray out to the stop, lift up insert and remove.

Practical Hints

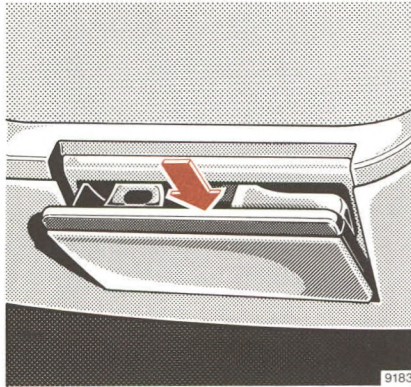

To remove rear ash tray:
Push the ash tray down while opening and remove.

To install ash tray:
Position ash tray squarely and push in.

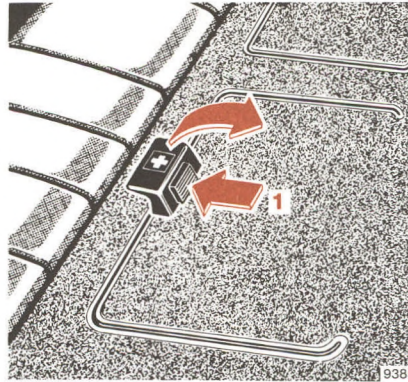

First Aid Kit

The first aid kit is stored in the hat shelf at the rear. To open the lid, push button (1).

Luggage or Ski Racks

We recommend the use of drip rail mounted ski and roof racks. These racks do not require additional supports (suction cups or legs). Such supports may lead to marring of the paint or even denting of the roof if excessive weight is placed on the rack. Your MERCEDES-BENZ dealer can give further advice.

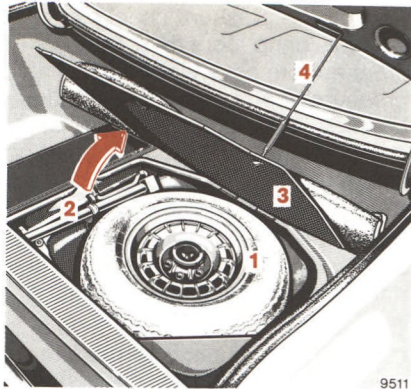

Spare Wheel, Jack, Vehicle Tool Kit

The spare wheel (1), jack (2) and vehicle tool kit are stored in a compartment below the trunk floor (3).

Prior to lifting up the cover, fold back mats and engage strap (4) in trunk lid.

Warning!

The jack is designed exclusively for jacking up the vehicle at the jack tubes provided on either side of the vehicle. Use the jack only to lift the vehicle during a tire change. Never get beneath the vehicle while it is supported only by the jack. Jack stands must be used when working under the vehicle.

Wheels, Tires

Replace wheels or tires with the same designation, manufacturer and type as shown on the original part.

See any authorized MERCEDES-BENZ dealer for information on tested and recommended wheels and tires for summer and winter operation. They can also offer more advice concerning tire service and purchase.

Front tires should be replaced in sets. If possible, the spare tire should be used on the rear wheels. We recommend that you break in new tires for approx. 100 km/ 60 miles at moderate speed.

After a wheel change, it is imperative that the wheel mounting bolts be retightened after approx. 800 km/ 500 miles. On new vehicles retightening is carried out in the course of

the 1st inspection. Retightening is also necessary when new wheels are fitted at a later date, e.g. when the spare wheel is used for the first time or when a new set of wheels with M + S tires is fitted.

For tire specifications, refer to "Technical Data".

Rotating wheels:

The wheels can be rotated according to the degree of tire wear while retaining the same sense of rotation. Rotating, however, should be carried out before the characteristic tire wear pattern (shoulder wear on front wheels and tread center wear on rear wheels) becomes visible at a mileage of 5000 – 10 000 km/ 3000 – 6000 miles as otherwise the driving properties deteriorate.

Slowly leaking air (e.g. due to a nail in the tire) may cause damage to the tire such as tread separation.

Regular tire pressure checks at intervals of no more than 14 days are therefore essential. For the tire pressure checks, keep in mind that hot tires show higher pressure than cold tires. See tire pressure chart on last page.

Should the tire pressure decrease constantly, check whether foreign objects have penetrated the tire or if rim or valve allow the air to leak.

Thoroughly clean the inner side of the wheels any time you rotate the wheels or wash vehicle underside.

Dented or bent rims cause tire pressure loss and damage to the tire beads. For this reason, check rims for damage at regular intervals.

The rim flanges must be checked for wear before a tire is mounted. Remove burrs, if there are any.

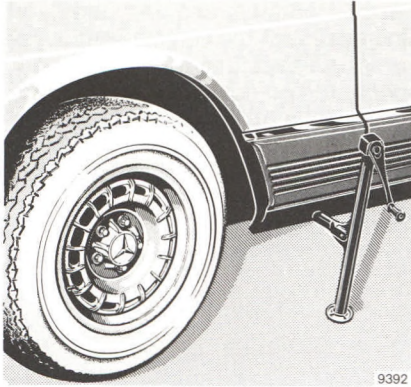

Changing Wheels

1. Set parking brake.
2. Move selector lever to position "P".
3. Prevent vehicle from rolling away by blocking wheels with wheel chocks: When changing a wheel on a hill, place chocks behind each wheel of the axle opposite to the axle to be worked on; on a level road, place one chock in front and one behind of the wheel that is diagonally opposite to the wheel being changed.
4. Using the combination wrench, loosen but do not yet remove the wheel bolts.
5. Clean jack supporting tube, if necessary. (Jack tubes are behind the front wheel housings and in front of the rear wheel housings.)
6. Insert jack arm fully into the tube hole up to the stop. Position the jack so that it will always be vertical as seen from the side, even on inclines. Jack up the vehicle until the wheel is clear off the ground.
7. Then unscrew wheel bolts completely. Keep bolt threads protected from dirt and sand. While removing last bolt, hold wheel against axle to avoid paint damage on rim.
8. Remove wheel.
9. Adjust the jack to allow the wheel to be slipped on without being lifted.
10. Slip on wheel and press against wheel mounting flange. Turn in wheel bolts.
To avoid paint damage, place wheel flat against hub and hold it there while installing first wheel bolt.
11. Lower car and remove jack. Tighten the five bolts evenly by tightening every other bolt until all the bolts are tight. Observe a tightening torque of 110 Nm/ 80 lb-ft.
12. Correct tire pressure.

Tire Inflation Pressure

A table (see fuel filler flap or last page) lists the tire inflation pressures specified for summer and winter tires as well as for the varying operating conditions.

Important!

Tire pressure differs by approx. 0.1 bar/1.5 psi per 10° C/18° F of air temperature change. Keep this in mind when checking tire pressure inside a garage – especially in the winter.

Example:

Room temperature =
approx. + 20° C/+ 68° F

Ambient temperature =
approx. 0° C/+ 32° F

Adjusted air pressure = specified
air pressure + 0.2 bar/+ 3 psi.

Tire pressures listed for light loads are minimum values offering high driving comfort. Increased inflation pressures for heavy loads produce favorable handling characteristics with lighter loads and are perfectly permissible. The ride of the vehicle, however, will become somewhat harder.

Tire temperature and pressure increase with the vehicle speed. Tire pressure should therefore only be corrected on cold tires. Correct tire pressure in hot tires only if pressure has dropped below the data listed in the table and the respective operating conditions are taken into consideration.

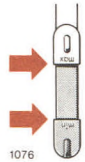
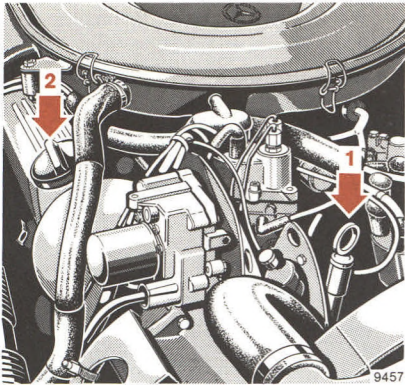

The vehicle should be parked on level ground and the oil level must be somewhere between the lower and the upper mark on dipstick (1); do not add in excess of the upper mark.

Wipe dipstick before any oil level measurement. To determine the oil level, check both sides of the dipstick. Always determine the oil level by means of the straight horizontal marking formed by the oil on one side of the dipstick.

For viscosity and capacity, see "Fuels, Coolants, Lubricants, etc." and last page.

Engine Oil Level Check

- 1 Dipstick
- 2 Oil filler cap

Check engine oil level regularly or after each fuel fill-up, with the engine off and at operating temperature (engine must be at operating temperature for some time).

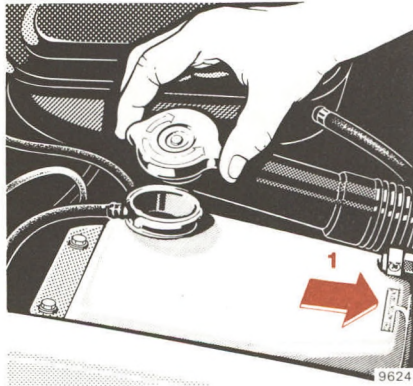

Checking Coolant Level

The coolant level can be checked visually at the transparent coolant reservoir.

To check the coolant level, the vehicle must be parked on level ground.

The coolant level must reach:

The marking (1, arrow) on the reservoir when the engine is cold.

Approx. 2 cm/0.8 in higher when the engine is at operating temperature.

Adding Coolant

If a small amount of coolant has to be added (due to evaporation of water), plain water can be used.

If a larger quantity of coolant has to be added, a 50/50 mixture of water and anticorrosion/antifreeze should be used.

Warning!

Do not remove pressure cap on coolant reservoir if engine temperature is above 90° C/194° F. Allow

engine to cool down before removing cap. The coolant reservoir contains hot water and is under pressure.

Using a rag, turn cap to first notch to relieve excess pressure. If opened immediately, hot scalding fluid and steam will be blown out under pressure.

The drain plugs are situated on the right and left side of the engine and on the radiator bottom.

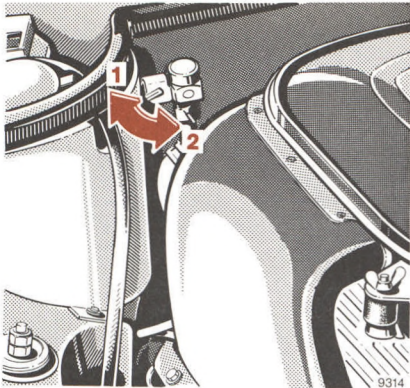

Automatic Transmission Fluid Level

At regular intervals and prior to a long trip, check automatic transmission fluid level and engine oil level.

Check transmission fluid level with the engine idling, parking brake engaged and selector lever in position "P". The vehicle must be parked on level ground. Prior to the check, allow engine to idle for approx. 1 to 2 minutes.

Measure fluid level with the dipstick completely inserted and the locking lever released (1).

Extreme cleanliness must be observed! To wipe the dipstick, use a clean, lintfree cloth. To fill the transmission with fluid, pour it through a fine-mesh filter into the dipstick opening. Even the slightest impurity may cause operational troubles.

The fluid level in the transmission is dependent upon its temperature.

The maximum and minimum fluid level marks on the dipstick are applicable references only if the transmission fluid has reached its normal operating temperature of 80° C/176° F.

If the transmission fluid cools down to 20–30° C/68–86° F, which is the normal shop temperature range, then the maximum fluid level will be approximately 5 mm/0.2 in below the minimum mark on the dipstick. We stress this point because a fluid change is normally performed when the transmission fluid has cooled down to shop temperature.

The fluid level must not exceed the dipstick maximum mark with the fluid at operating temperature. Drain or siphon off excess fluid, if required.

Then push dipstick all the way in and swing locking lever downwards (2).

Electrical System

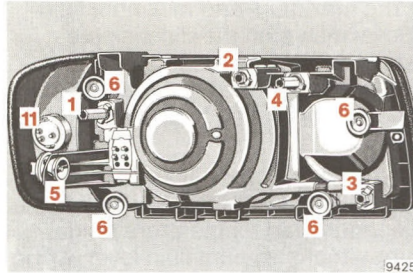

Headlamp Adjustment

Correct headlamp adjustment is extremely important. Check and readjust headlamps at regular intervals and when a lamp has been replaced.

Replacing Bulbs

Only handle new bulbs for headlamps and tail lamps with tissue paper or similar.

Install only 12 volt bulb with the specified watt rating.

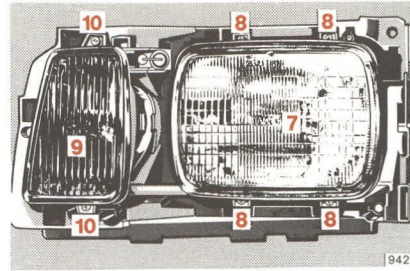

Headlamp Unit

- 1 Headlamp vertical adjusting screw
- 2 Headlamp horizontal adjusting screw
- 3 380 SE, 500 SEL:
Fog lamp vertical adjusting screw
- 4 380 SE, 500 SEL:
Fog lamp horizontal adjusting screw
- 5 Securing screw for housing of turn signal, standing, side marker and parking lamps

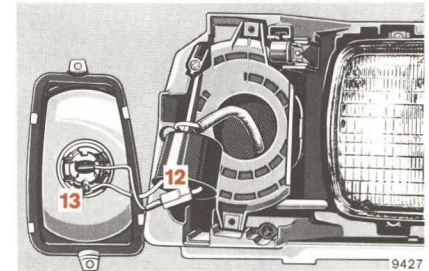

- 6 Securing screw for cover of sealed-beam unit and for 380 SE, 500 SEL fog lamp
- 7 Sealed-beam unit for high and low beam
- 8 Securing screws for sealed-beam unit
- 9 380 SE, 500 SEL:
Fog lamp
- 10 380 SE, 500 SEL:
Securing screws for fog lamp
- 11 Turn signal, standing, side marker and parking lamps

Replacing bulbs:

Bulbs for turn signal, standing, side marker and parking lamps (21/5 W/32/3 cp):

Turn lamp holder with bulb to the left and remove. Depress bulb, turn to the left and take out.

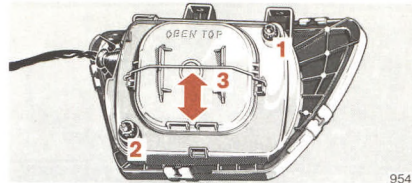

9547

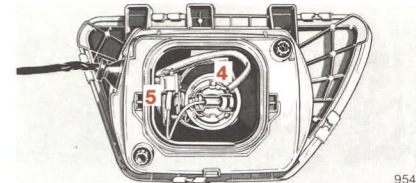

9548

Sealed-beam unit for high and low beam (Sealed-beam/Halogen):

Loosen securing screw (5) and pull housing out of bracket. Then loosen securing screws (6) and remove front cover. Remove securing screws (8) from retaining frame and take out sealed-beam unit. Pull off connector.

380 SE, 500 SEL:

Bulb for fog lamp (H 3):

Loosen securing screw (5) and pull housing out of bracket. Then loosen securing screws (6) and remove front cover. Remove securing screws (10) and take out lamp holder. Pull off plug connector (12). Disengage retaining spring (13) and take out bulb.

Fog Lamp 500 SEC

The bulb for the fog lamp is accessible through the wheel well for the purpose of bulb replacement.

- 1 Vertical adjustment screw for the fog lamp
- 2 Horizontal adjustment screw for the fog lamp

- 4 Bulb for fog lamp (H 3):
Unsnap the bottom of protective cap and remove towards the top. Loosen clip (3) and remove cover.

Unplug electric connector (5). Unhook retaining spring and remove bulb.

Electrical System

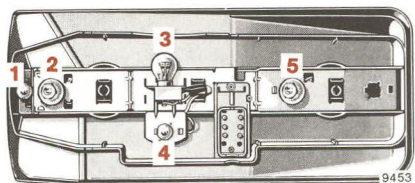
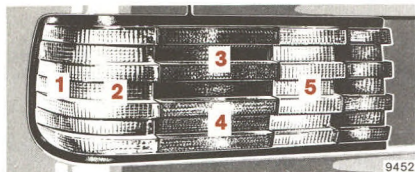

Tail Lamp Assemblies

- 1 Side marker lamp (10 W/6 cp)
- 2 Turn signal lamp (21 W/32 cp)
- 3 Stop lamp (21 W/32 cp)
- 4 Tail, parking and standing lamp (10 W/6 cp)
- 5 Backup lamp (21 W/32 cp)

Turn both locks in the trunk to the left as far as the stop and detach lamp bracket. To replace the bulbs, depress, turn to the left and remove.

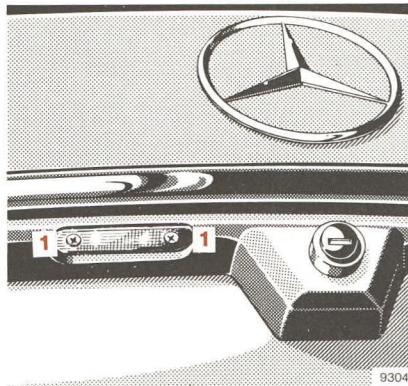

License Plate Lamps (5 W festoon lamp)

Loosen both the securing screws (1) and take out lamp.

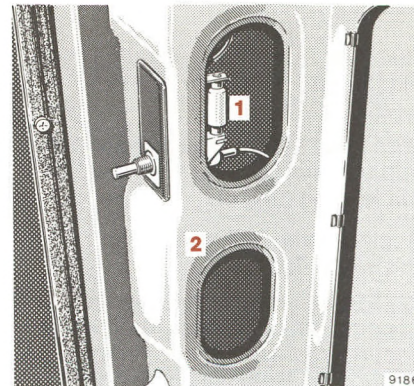

Trunk Lamp (10 W festoon lamp)

Trunk lamp (1) is easily accessible when trunk lid (2) is open.

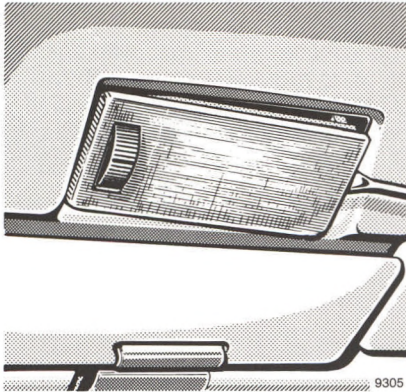

Interior Lamps (10 W festoon lamp)

To replace the bulb, lift off front lamp at RH side, pull it out and open reflector.

The same applies to the removal of the rear lamp.

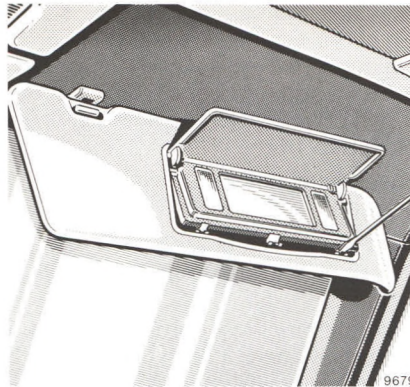

Sun Visor Lamp (5 W festoon lamp)

To replace a bulb, pry off the cover by inserting a screwdriver in the left and right slots located on the lower edge.

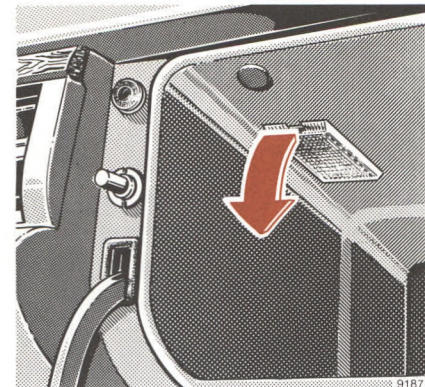

Glove Compartment Lamp
(5 W festoon lamp)

To replace the bulb, pull out lamp.

Reading Lamps in the Rear Passenger Compartment
(4 W/2 cp)

To change the bulbs, pull out lamps.

Electrical System

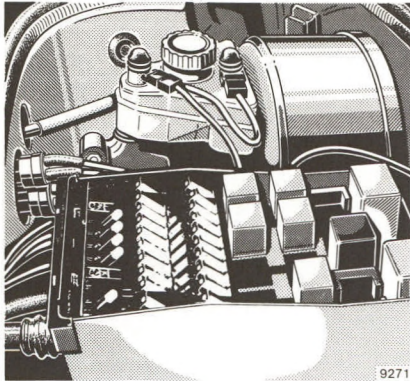

Fuses

The fuse box is located in the engine compartment.

All fuse protected equipment is shown on a label in the lid of the fuse box.

Fuse arrangement in the box – starting at the engine side and proceeding outwards –

RH row: odd numbers 1, 3, 5, etc. up to 13; LH row: even numbers 2, 4, 6, etc. up to 14.

Fuses must not be repaired or bridged.

Spare fuses are stored in the fuse box (observe amperage and color code).

Before changing a burned out fuse, determine the cause of the short circuit.

After replacing a fuse, engage lid of fuse box at rear and lock with clamp at front.

Spark Plugs

This vehicle is equipped with spark plugs as required for driving in the USA. Should additional information be necessary, your MERCEDES-BENZ dealer will be happy to offer advice.

Battery

Check fluid level in each cell approximately every four weeks, and more frequently during the summer and in hot climates.

Refill battery only with distilled water. Do not use metal funnels or push through the overfill-protection diaphragms in filler holes.

The battery is completely filled when the water stops draining through the overfill-protection diaphragm.

To check the battery charge with a hydrometer, push its tip through the overfill-protection diaphragm and take the electrolyte sample.

Coat battery terminal clamps with acidproof grease. Keep battery clean and dry.

The service life of the battery is also dependent on its condition of charge. It must be maintained sufficiently charged for the battery to last an optimum length of time.

Therefore, we recommend that you have the battery charge checked frequently if you use the vehicle mostly for short distance trips, or if it is not used for long periods of time.

Only charge battery with a battery charger when it is disconnected from the vehicle electrical circuit.

Warning!

Battery fluid contains sulfuric acid. Do not allow this fluid to come in contact with eyes, skin, or clothing.

In case it does, immediately flush affected area with water, if necessary seek medical help.

A battery will also produce hydrogen gas, which is flammable and explosive. Keep flames or sparks away from battery, i.e. improper connection of jumper cables, cigarette smoking, etc..

While the engine is running the battery terminal clamps must not be loosened or detached as otherwise the alternator and other electronic units would be damaged.

Only tow vehicle with the battery connected.

Windshield Wipers

In order to renew or release frozen windshield wiper blades, the windshield wiper arms can be pulled out of their recess by hand. Sufficient force must be applied to overcome spring resistance.

In order to ensure operation of the windshield wiper even when it is snowing heavily, an overload protection has been installed. It becomes effective if a certain wiping resistance is exceeded as a result of snow accumulation. The windshield wiper arm will then no longer return completely to its initial position, although the windshield wiper motor continues to run a full cycle. If this condition is encountered, the accumulated snow should be manually removed when it is safe to do so.

Emergency Operation of Sliding Roof

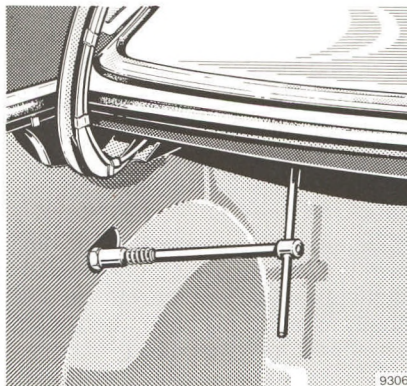

The sliding roof can be opened or closed manually should an electrical malfunction occur.

Remove small access plug in left sidepanel of trunk. Insert socket wrench (from tool kit) through opening in panel and place on the hex-drive on the electric motor. Turn socket wrench as desired to open or close roof.

To close the sliding roof, turn wrench clockwise. 500 SEC turn wrench counterclockwise.

Unlocking the Fuel Filler Flap

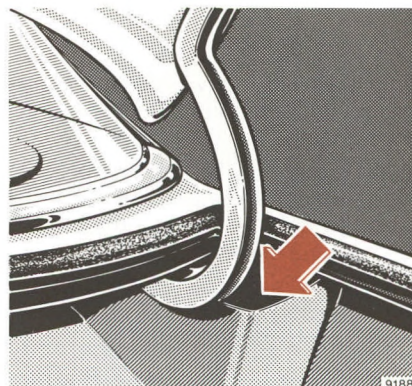

If the central locking system does not release the fuel filler flap automatically, pull down right trunk panel slightly and pull back the connecting rod between the vacuum element and door tab.

Jump Starting

If the battery is discharged the engine can be started with jumper cables (minimum cable cross section is 25 mm²) and the (12 V) battery of another vehicle. Proceed as follows:

1. Turn key to steering lock position "0".
2. First connect jumper cables to the positive battery terminals and then to the negative terminals.
3. Start and run engine of jumper vehicle at high idle.
4. Start engine of the disabled vehicle in the usual manner.
5. After the engine has started, first remove jumper cables from the negative battery terminals and then from the positive terminals.

Instructions:

A discharged battery can freeze at approx. $-10^{\circ}\text{C}/+14^{\circ}\text{F}$. In all cases it must be thawed out before jumper cables are used.

Warning!

Never lean over batteries while jump starting, you might get burned.

Battery fluid contains sulfuric acid. Do not allow this fluid to come in contact with eyes, skin, or clothing. In case it does, immediately flush affected area with water, if necessary seek medical help.

A battery will also produce hydrogen gas, which is flammable and explosive. Keep flames or sparks away from battery, i.e. improper connection of jumper cables, cigarette smoking, etc..

Tow-starting and Towing the Vehicle

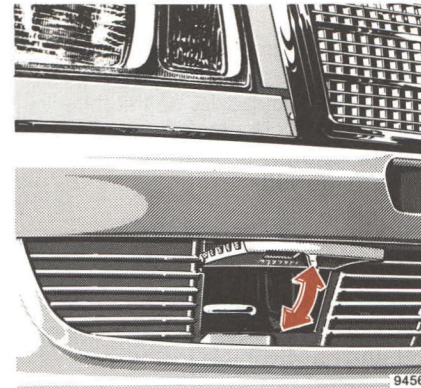

The front towing eye is located on the RH side behind a flap and the rear towing eye on the RH side below the bumper.

Only tow-start vehicle with the battery cables connected and the key in steering lock position "2".

Tow-starting and Towing the Vehicle

Warning!

When the engine is not running, both the service brake and the steering are without power assistance. Under these circumstances, a much greater effort is necessary to steer or stop the vehicle.

Emergency Engine Start (Tow-starting)

Shift selector lever to position “N”. Turn key in steering lock to position “2” and have vehicle towed.

After attaining a towing speed of 30 km/h/18 mph (with cold transmission) or 50 km/h/30 mph (with warm transmission), shift selector

lever to position “2” to tow-start the engine. Only touch the accelerator when the engine is turning. As soon as the engine has started, quickly return selector lever to “N”.

If the engine fails to fire within a few seconds, return the selector lever from “2” to “N” as otherwise the transmission may be damaged.

For another starting attempt, tow car again for a short while with the selector lever in position “N” and then repeat starting procedure.

The same procedure may be used for starting the engine while rolling downhill.

Towing a Vehicle

The vehicle may be towed with the all of wheels on the ground and the selector lever in position “N” for distances up to 120 km/75 miles and at a speed not to exceed 50 km/h/30 mph.

To positively avoid a possibility of damage to the transmission, however, we recommend to disconnect the drive shaft at the rear axle drive flange on any towing beyond a short tow to a nearby garage.

Front towing: Attach J-hooks to the subframe crossmember. Position towbar under the radiator support. Attach safety chains to the lower control arms, between the springs and shock absorbers.

Rear towing: Attach T-hooks to the tie-down slots. Position towbar under rear of trunk floor. Attach safety chains to the lower control arms.

**Technical Data
Fuels Coolants
Lubricants etc.**



Identification Plates

When ordering spare parts, please quote chassis and engine numbers.

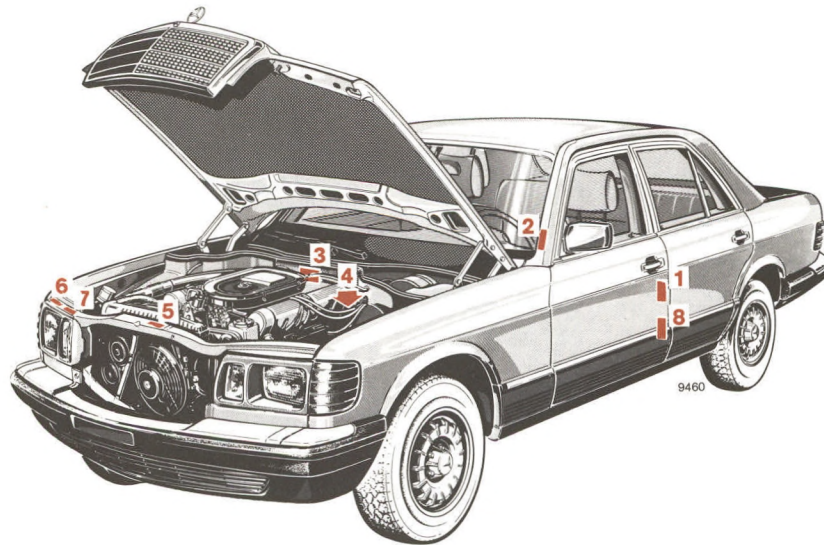

- 1 Certification Tag (left door pillar)
- 2 Identification Tag (left window post)

- 3 Chassis No.
- 4 Engine No.
- 5 Body No. and Paintwork No.

- 6 Emission Control Tag (500 SEC left side)
- 7 Information Tag California version Vacuum line routing for emission control system
- 8 Emission Control Tag Catalyst Information

Vehicle Data Cards

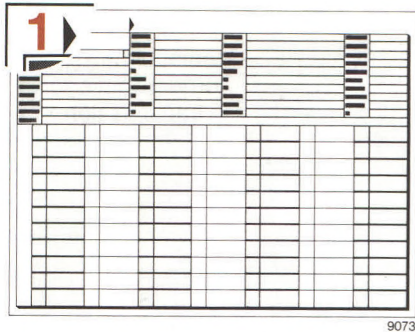

The vehicle data cards bear all the important data relating to your vehicle.

Data card No. 1 bears the key number and should never be left in the vehicle. Submit this card to your authorized MERCEDES-BENZ dealer to request a replacement key in case of loss.

Data card No. 2 bears no key data and is kept in the Maintenance Booklet. Presenting this card to the dealer will facilitate the processing of the order.

Warranty Coverage

Your car is covered under the terms of the “warranties” printed in the Owner’s Service and Warranty Policy Booklet and your dealer will exchange or repair any defective parts in accordance with the terms of the following warranties:

1. New vehicle limited warranty
2. Emission systems warranty
3. Emission performance warranty
4. California emission control systems warranty (state of California only unless purchased optionally for diesel models).

Loss of Owner’s Service and Warranty Policy

Should you lose your Owner’s Service and Warranty Policy Booklet, have your local MB dealer arrange for a replacement. It will be mailed to you.

Technical Data 380 SE

Type.....	380 SE (126.032) ¹
Engine	
Engine.....	116
Mode of operation.....	4-stroke engine, gasoline injection
No. of cylinders	8
Bore	88.0 mm/3.46 in
Stroke	78.9 mm/3.10 in
Total piston displacement	3839 cm ³ /234.3 in ³
Compression ratio	8.3
Output according to SAE.....	116 kW/4750 rpm/ 155 net-bhp/4750 rpm
Firing order	1-5-4-8-6-3-7-2
V-belts:	
Water pump — fan — power steering pump	2 V-belts 9.5 x 1100 mm
Alternator.....	9.5 x 990 mm
Air conditioning	12.5 x 920 mm
Air pump.....	9.5 x 750 mm

Transmission

Design	Automatic four-speed torque-converter transmission
--------------	--

Steering System

Design	Power steering
--------------	----------------

Rims — Tires

Rims (forged light alloy rims)	6½ J x 14 H 2
Summer tires:	
Radial-ply tires.....	205/70 R 14 93 H
Winter tires:	
Radial-ply tires.....	205/70 R 14 93 Q M+S 205/70 R 14 93 T M+S

¹ The quoted data apply only to the standard vehicle. See an authorized MERCEDES-BENZ dealer for the corresponding data of all special bodies and special equipment.

Electrical System

Alternator	14 V/80 A
Starter motor	12 V/1.5 kW
Battery	12 V/66 Ah
Spark plugs.....	see "last page"
Weights	See certification tag

Main Dimensions

Overall vehicle length	5145 mm/202.6 in
Overall vehicle width	1820 mm/ 71.7 in
Overall height.....	1436 mm/ 56.5 in
Wheel base.....	2935 mm/115.6 in
Track, front	1545 mm/ 60.8 in
Track, rear.....	1517 mm/ 59.7 in



Technical Data 500 SEL, 500 SEC

Type..... 500 SEL (126.037)¹
500 SEC (126.044)¹

Engine

Engine..... 117
Mode of operation..... 4-stroke engine,
gasoline injection
No. of cylinders 8
Bore..... 96.5 mm/3.80 in
Stroke..... 85.0 mm/3.35 in
Total piston displacement 4973 cm³/303.5 in³
Compression ratio 8
Output according to SAE..... 137 kW/4500 rpm/
184 net-bhp/4500 rpm
Firing order 1-5-4-8-6-3-7-2

V-belts:

Water pump — fan — power
steering pump 2 V-belts 9.5 x 1100 mm
Alternator..... 9.5 x 1005 mm
Air conditioning 12.5 x 930 mm
Air pump..... 9.5 x 750 mm

¹ The quoted data apply only to the standard vehicle. See an authorized MERCEDES-BENZ dealer for the corresponding data of all special bodies and special equipment.

Transmission

Design Automatic four-speed
torque-converter
transmission

Steering System

Design Power steering

Rims — Tires

Rims (forged light alloy rims) 6½ J x 14 H 2
Summer tires:
Radial-ply tires..... 205/70 R 14 93 H
Winter tires:
Radial-ply tires..... 205/70 R 14 93 Q M+S
205/70 R 14 93 TM+S

Electrical System

Alternator..... 14 V/80 A
Starter motor 12 V/1.5 kW
Battery 12 V/66 Ah
Spark plugs see "last page"

Main Dimensions 500 SEL

Overall vehicle length	5285 mm/208.1 in
Overall vehicle width	1820 mm/ 71.7 in
Overall height.....	1440 mm/ 56.7 in
Wheel base	3070 mm/120.9 in
Track, front	1545 mm/ 60.8 in
Track, rear	1517 mm/ 59.7 in

Main Dimensions 500 SEC

Overall vehicle length	5060 mm/199.2 in
Overall vehicle width.....	1828 mm/ 72.0 in
Overall height.....	1406 mm/ 55.4 in
Wheel base.....	2845 mm/112.0 in
Track, front	1545 mm/ 60.8 in
Track, rear.....	1517 mm/ 59.7 in

Weights..... See certification tag

Fuels Coolants Lubricants etc. Capacities

Vehicle components and their respective lubricants must match.

Therefore use only brands tested and recommended by us.

Inquire at your authorized MERCEDES-BENZ dealer.

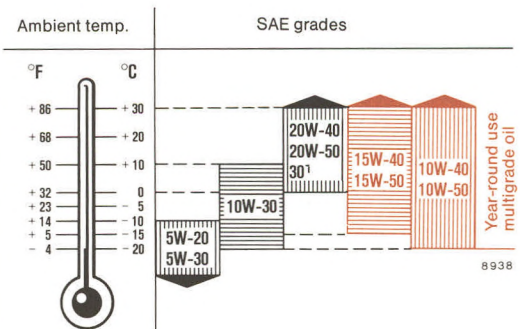
	Capacity	Fuels, coolants, lubricants, etc.
<p>Total oil capacity in case of engine oil and filter change</p>	<p>8.0 l/8.5 US qt</p>	<p>Recommended engine oil</p>  <p>Ambient temp. SAE grades</p> <p>°F °C</p> <p>+86 +30 +68 +20 +50 +10 +32 0 +23 -5 +14 -10 +5 -15 -4 -20</p> <p>5W-20 5W-30 10W-30 20W-40 20W-50 30¹ 15W-40 15W-50 10W-40 10W-50</p> <p>Year-round use multigrade oil</p> <p>8938</p> <p>¹ SAE 40 may be used if ambient temperatures constantly exceed +30° C/ +86° F.</p>
<p>Automatic transmission</p>	<p>Initial fill: 8.6 l/9.1 US qt Fluid change: 7.7 l/8.1 US qt</p>	<p>Automatic transmission fluid for automatic transmission²</p> <p>² Any authorized MERCEDES-BENZ dealer will advise you on recommended brands.</p>

Fuels Coolants Lubricants etc. Capacities

	Capacity	Fuels, coolants, lubricants, etc.
Rear axle	1.3 l/1.4 US qt	Hypoid gear oil SAE 90, 85 W 90 ¹
Accelerator control linkage		Hydraulic fluid
Power steering	1.2 l/1.3 US qt	Automatic transmission fluid for power steering ¹
Front wheel hubs	60 g each, approx. 2.1 oz. each, approx.	High temperature roller bearing grease
Grease nipples		Multipurpose or lubrication grease
Door locks		Powdered graphite
Battery terminals		Bosch special grease
Brake reservoir	approximately 0.5 l/0.5 US qt	Brake fluid ¹
Windshield washer system	approximately 5.0 l/5.3 US qt	Windshield washer solvent
Fuel tank including a reserve of	approximately 90 l/23.8 US gal approximately 12.5 l/3.3 US gal	Unleaded gasoline: Average Octane of Research and Motor 87 (RON of 91)
Cooling system	380 SE	Coolant ¹
	500 SEL, 500 SEC	

¹ Any authorized MERCEDES-BENZ dealer will advise you on recommended brands.

Engine Oils

Engine oils are specifically tested for their suitability in our engines. Therefore, use only engine oils recommended by us. Information on recommended brands is available at any authorized MERCEDES-BENZ dealer.

On a new vehicle, the engine is filled with break-in oil in the factory. This oil is specially developed for the specific operating conditions during the first 1300–1600 km/800–1000 miles.

A recommended engine oil may be used for topping up if the oil level drops to the dipstick minimum mark prior to the first service 1300–1600 km/800–1000 miles.

Fuel Requirements

Use only unleaded gasoline meeting ASTM standard D 439:

The octane number (posted at the pump) must be **87 min.** It is an average of both, the Research (R) octane number and the Motor (M) octane number: $(R + M)/2$. This is also known as ANTI-KNOCK INDEX.

Unleaded gasoline containing oxygenates such as Ethanol, MTBE, IPA, IBA and TBA can be used provided the ratio of either one of these oxygenates to gasoline does not exceed 10%.

The ratio of Methanol to gasoline must not exceed 3%. In both cases, this does not include the cosolvents.

Using mixtures of Ethanol and Methanol is not allowed. MTBE may, however, be added up to 15%. Gasohol, which contains 10% Ethanol and 90% unleaded gasoline, can be used.

These blends must also meet all other fuel requirements such as resistance to spark knock, boiling range, vapor pressure, etc..

Brake Fluid

During the course of the operation of the vehicle, the boiling point of the brake fluid is continuously reduced through the absorption of moisture from the atmosphere. Under extremely hard operating conditions, this moisture content can lead to the formation of vapor in the system thus reducing the system's efficiency. The brake fluid must therefore be replaced annually, preferable in the spring. It is recommended to use only brake fluid approved by MERCEDES-BENZ.

Your MERCEDES-BENZ dealer will provide you with additional information.

Coolants

The engine coolant is a mixture of water and anticorrosion/antifreeze, which provides:

- corrosion protection
- freeze protection
- boiling protection (by increasing the boiling point).

The cooling system was filled at the factory with a coolant providing freeze protection to $-30^{\circ}\text{C}/-22^{\circ}\text{F}$ and corrosion protection. The red area of the temperature gauge is matched to the heating properties of this coolant solution.

The coolant solution must be used year round to provide the necessary corrosion protection and increase in the boil-over protection. You should have it replaced every 3 years.

To provide the important corrosion protection, the solution must be at least 33% anticorrosion/antifreeze (equals a freeze protection to $-20^{\circ}\text{C}/-4^{\circ}\text{F}$). If you use a solution that is more than 55% anticorrosion/antifreeze (freeze protection to

$-40^{\circ}\text{C}/-40^{\circ}\text{F}$), the engine temperature will increase due to the lower heat transfer capability of the solution. Therefore, do not use more than this amount of anticorrosion/antifreeze.

If the coolant level is low, water and M-B anticorrosion/antifreeze should be used to bring it up to the proper level (have cooling system checked for signs of leakage).

The water in the cooling system must meet minimum requirements, which are usually satisfied by normal drinking water. If you are not sure about the water quality, consult your authorized MERCEDES-BENZ dealer.

Anticorrosion/antifreeze

Your vehicle contains a number of aluminium parts. The use of aluminium components in motor vehicle engines necessitates that anticorrosion/antifreeze/coolant used in such engines be specifically formulated to protect the aluminium parts. (Failure to use such anticorrosion/antifreeze/coolant may result in a significantly shortened service life.)

While there may be a number of anticorrosion/antifreeze/coolants available which will provide the requisite protection, all such products have not been tested for MERCEDES-BENZ vehicles. The following product, however, is recommended for use in your car: MERCEDES-BENZ Anticorrosion/Antifreeze Agent.

Before the start of the winter season (or once a year in the hot southern regions), you should have the anticorrosion/antifreeze concentration checked. The coolant is also regularly checked each time you bring your vehicle to your authorized MERCEDES-BENZ dealer for maintenance service.

	380 SE	500 SEL 500 SEC
Freeze protection	Anticorrosion/ antifreeze liter/US qt	
-30°C	5.50 l/	5.75 l/
-22°F	5.8 US qt	6.1 US qt
-40°C	6.50 l/	6.75 l/
-40°F	6.9 US qt	7.1 US qt

Service Literature

Customers who are interested in ordering service literature for their vehicles are advised to contact our subsidiaries in the U.S. or Canada at the following addresses, respectively

for U.S.A.: Mercedes-Benz of N.A. Inc.
One Mercedes Drive
P.O. Box 350
Montvale, New Jersey 07645
Att: Technical Publications
Tel: (201) 573-0600

for Canada: Mercedes-Benz of Canada
849 Eglinton Ave., East
Toronto 17, Ont., Canada
Att: Service Department
Tel: 416-425-3550

The above companies will be happy to handle any such requests from customers.

We consider this to be the best way to obtain accurate information for your vehicle.

This has been prepared as required of all manufacturers of passenger cars under Title 49, Code of U.S. Federal Regulations, Part 575 pursuant to the “National Traffic and Motor Vehicle Safety Act of 1966”.

Uniform Tire Quality Grading

Relevant tire grade information on tire flanks.

All passenger car tires must conform to federal safety requirements in addition to these grades.

Traction “A”, “B”, “C”

The traction grades, from highest to lowest, are “A”, “B” and “C” and they represent the tire’s ability to stop on wet pavement as measured under controlled conditions on specified government test surfaces of asphalt and concrete. A tire marked “C” may have poor traction performance.

Warning! The traction grade assigned to this tire is based on braking (straightahead) traction tests and does not include cornering (turning) traction.

Temperature “A”, “B”, “C”

The temperature grades of “A” (the highest), “B” and “C” representing the tire’s resistance to the generation of heat and its ability to dissipate heat when tested under controlled conditions on a specified indoor laboratory test wheel.

Sustained high temperature can cause the material of the tire to degenerate and reduce tire life, and excessive temperature can lead to sudden tire failure. The grade “C” corresponds to a level of performance which all passenger car tires must meet under the Federal Motor Vehicle Safety Standard No. 109.

Grades “B” and “A” represent higher levels of performance on the laboratory test wheel than the minimum required by law. **Warning!** The temperature grade for this tire is established for a tire that is properly inflated and not overloaded. Excessive speed, underinflation, or excessive loading, either separately or in combination, can cause heat buildup and possible tire failure.

Consumer Information 380 SE

Vehicle Stopping Distance

This figure indicates braking performance that can be met or exceeded by the vehicles to which it applies, under different conditions of loading and with partial failures of the braking system. The information presented represents results obtainable by skilled drivers under controlled road and vehicle conditions, and the information may not be correct under other conditions.

Description of the vehicles to which this table applies: **380 SE**

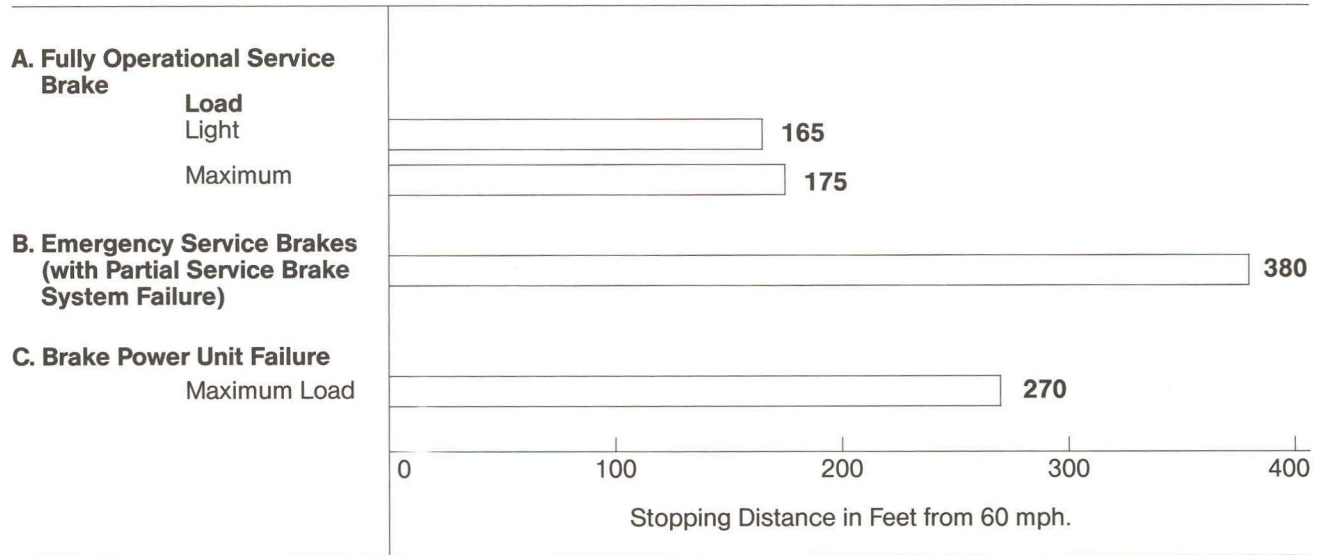

Vehicle Stopping Distance

This figure indicates braking performance that can be met or exceeded by the vehicles to which it applies, under different conditions of loading and with partial failures of the braking system. The information presented represents results obtainable by skilled drivers under controlled road and vehicle conditions, and the information may not be correct under other conditions.

Description of the vehicles to which this table applies: **500 SEL, 500 SEC**

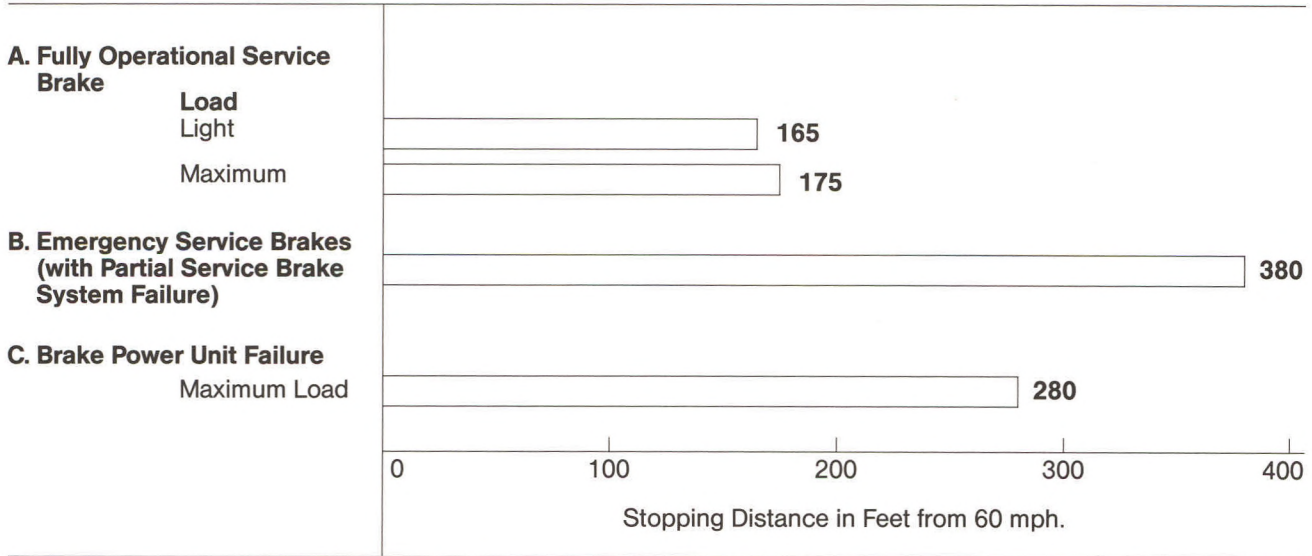

Printed in Germany

We reserve the right to modify the technical details of the vehicle as given in the data and illustrations of this Owner's Manual (s.e.e.o.). Reprinting, translation and copying, even of excerpts, is not permitted without our prior authorization in writing.

ZKD/9.84.8/MD

What You Should Know at the Gas Station

- **Fuel:** Unleaded gasoline: Average Octane of Research and Motor 87 (RON of 91).
Fuel tank capacity approx. 90 l/23.8 US gal, this includes approx. 12.5 l/3.3 US gal reserve.

Only fill fuel tank until the filler nozzle unit cuts out – do not overfill.

- **Engine Oil:** Engine oil level check, see page 75.

Quantity differential between upper and lower dipstick marking level: 2.0 l/2.1 US qt.

Year-round multigrade oils 10 W-40, 10 W-50, 15 W-40, 15 W-50.

For further information, refer to page 94.

- **Automatic Transmission:** Automatic transmission fluid for automatic transmission.

For level checks and replenishment, refer to page 77.

- **Tire Pressure:** Cold tires:
For driving up to 160 km/h/100 mph

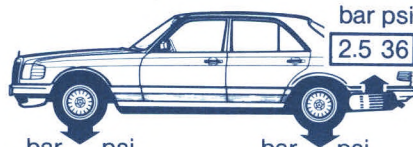

Summer tires	normal load
	maximum load
Winter tires:	

bar	psi
2.0 ¹	28 ¹
2.1 ¹	30 ¹
2.2 ¹	32 ¹

bar	psi
2.1 ¹	30 ¹
2.4 ¹	34 ¹
2.5 ¹	36 ¹

- **Coolant:** For normal replenishment, use water (potable water quality).

For further information (e.g. anticorrosion/antifreeze), refer to page 97.

- **Bulbs:** High and low beams: Sealed beam/ Halogen, tail, parking and standing lamps 10 W/6 cp, turn signal, standing, side marker and parking lamps, front 21/5 W/32/3 cp, turn signal lamps, rear 21 W/32 cp, stop lamps 21 W/32 cp, license plate lamps 5 W festoon lamp.

- **Spark Plugs:**

380 SE: Beru 14-9 D, Beru 14-9 DU, Bosch W 9 D, Bosch W 9 DC, Champion N 12 Y, Champion N 12 YC.

500 SEL, 500 SEC: Beru 14-8 D, Beru 14-8 DU, Bosch W 8 D, Bosch W 8 DC, Champion N 11 Y, Champion N 11 YC.

Warm tires:
Pressure may rise by up to +0.3 bar/+4 psi.

Never release any air from a warm tire to off-set this pressure increase!

¹ For driving above 160 km/h/ 100 mph +0.4 bar/+6 psi.

Daimler-Benz AG
Stuttgart-Untertuerkheim
Zentralkundendienst



Mercedes-Benz
service

126 584 00 97

Order No. 6550 5503 12

LISA-Ausgabe B

1085

