

# Owner's Manual

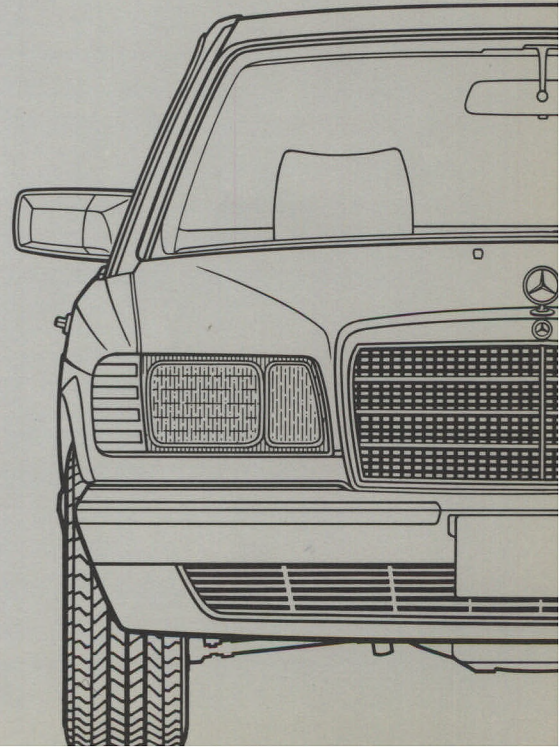

**420 SEL**  
**560 SEL**  
**560 SEC**

1986



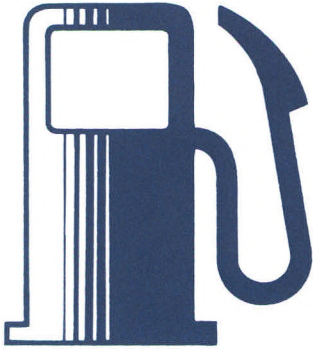

16

## Drive Sensibly – Save Fuel

Fuel consumption, to a great extent, depends on driving habits and operating conditions.

To save fuel you should:

- keep tires at the recommended inflation pressures
- remove unnecessary loads
- remove ski racks or roof-mounted luggage racks when not in use
- allow engine to warm up under low load use
- avoid frequent acceleration and deceleration
- have all maintenance work performed at regular intervals by an authorized MERCEDES-BENZ dealer.

Driving in cold weather, in stop-and-go city traffic, on short trips, and in hilly country also increase fuel consumption.



# Owner's Manual

---



**420 SEL**  
**560 SEL**  
**560 SEC**

Model 126

1986

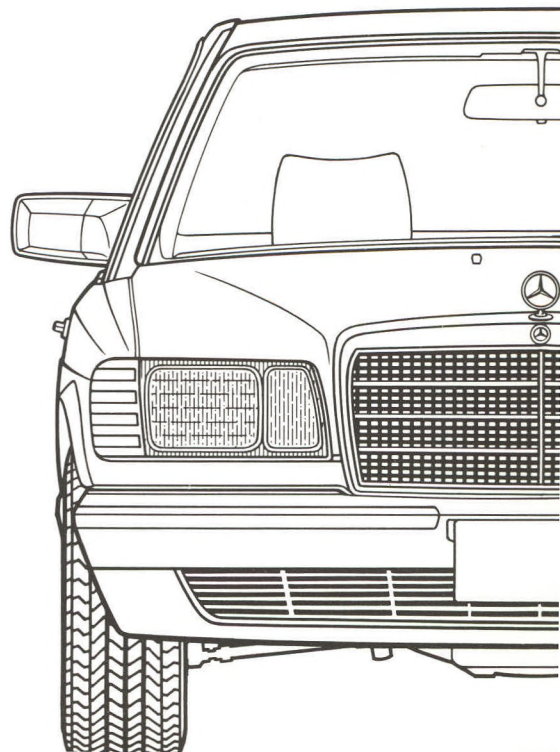

**Printed in Germany**

We reserve the right to modify the technical details of the vehicle as given in the data and illustrations of this Owner's Manual (s.e.e.o.). Reprinting, translation and copying, even of excerpts, is not permitted without our prior authorization in writing.

ZKD / 4.86.12/MD

Our company and staff congratulate you on the purchase of your new MERCEDES-BENZ.

Your selection of our product is demonstration of your trust in our company name. Further, it exemplifies your desire to own an automobile that will be as such as possible easy to operate and provide years of service.

Your MERCEDES-BENZ represents the efforts of many skilled engineers and craftsmen. To ensure your pleasure in owning it, we ask you to make a small investment of your time:

- Please read this manual carefully before putting it aside.
- Please consider the recommendations contained in this manual. They are designed to acquaint you with the operation of your MERCEDES-BENZ.

We extend our best wishes for many miles of safe, pleasurable driving.

Daimler-Benz Aktiengesellschaft



## **Introduction**

This Owner's Manual contains a great deal of useful information. We urge you to read it carefully and familiarize yourself with the vehicle before driving.

For your own safety and longer service life of the vehicle, we urge you to follow the instructions and warnings. Ignoring them could result in damage to the vehicle or personal injury.

Your vehicle may have some or all of the equipment described. Therefore, you may find explanations of equipment not installed in your vehicle. If you have any questions about the operation of any equipment, your MERCEDES-BENZ dealer will be glad to demonstrate the proper procedures.

## **Owner's Service and Warranty Policy**

The Owner's Service and Warranty Policy Booklet contains detailed information about the warranties covering your MERCEDES-BENZ, including:

- New Car Limited Warranty
- Emissions Systems Warranty
- Emission Performance Warranty
- California Emission Control System Warranty (California Only)

## **Maintenance**

The Maintenance Booklet describes all the necessary maintenance work which should be performed at regular intervals.

Always have the Maintenance Booklet with you when you take the vehicle to a MERCEDES-BENZ dealer for service. The Service Advisor will record each service.

## **Roadside Assistance**

Although your Mercedes-Benz is built to be as trouble-free as possible, a Roadside Assistance Program is available to provide emergency roadside service after normal dealer hours and on weekends and holidays in the contiguous United States.

Roadside Assistance is available Monday through Friday from 5:00 PM to 12:00 Midnight and on Saturday, Sunday and legal holidays from 8:00 AM to 12:00 Midnight. In the event of a breakdown during these hours, telephone this toll-free number: 1-800-222-0100.

For additional information, refer to the Mercedes-Benz Roadside Assistance Program Booklet in your glove compartment.

### **Change of Address or Ownership**

If you change your address, be sure to send in the “Change of Address Notice” found in the Owner’s Service and Warranty Policy Booklet. It is in your own interest that we can contact you should the need arise.

If you sell your Mercedes, please leave all owner’s literature with the vehicle to make it available to the next owner.

If you bought this vehicle used, be sure to send in the “Notice of Purchase of Used Car” found in the Owner’s Service and Warranty Policy Booklet.

### **Operating Your Vehicle Outside the U.S.A. or Canada**

If you plan to operate your vehicle in foreign countries, please be aware that:

- unleaded fuels for vehicles with catalytic converters may not be available; the use of leaded fuels will damage the catalyts,
- fuel may have a considerably lower octane rating, and improper fuel can cause engine damage,
- service facilities or replacement parts may not be readily available.

Certain Mercedes-Benz models are available for delivery in Europe under our European Delivery Program. For details, consult your authorized MERCEDES-BENZ dealer or write to:

Mercedes-Benz of North America, Inc.  
European Delivery Department  
One Mercedes Drive  
Montvale, NJ 07645





---

**Instruments and Controls, Starting the Engine  
Driving Hints, Service and Maintenance**

---

**Operation**

---

**Driving**

---

**Practical Hints**

---

**Technical Data  
Fuels Coolants Lubricants etc.**

---

**Index**

---

## Check Regularly and Before a Long Trip

See page 112

## What You Should Know at the Gas Station

See last page

## The First 1500 km (1000 Miles)

The more cautiously you treat your engine during the break-in period, the more satisfied you will be with its performance later on. Therefore, drive your vehicle during the first 1500 km (1000 miles) at moderate vehicle and engine speeds.

During this period, avoid heavy loads (full throttle driving) and high RPMs (no more than  $\frac{3}{4}$  of maximum permissible speed in each gear).

Avoid accelerating by kickdown. It is not recommended to brake the vehicle by manually shifting to a lower gear. We recommend to select positions "3" or "2" only at moderate speeds (for hill driving).

After 1500 km (1000 miles) speeds may gradually be increased to the permissible maximum.

# **Instruments and Controls, Starting the Engine Driving Hints, Service and Maintenance**

Instruments and Controls	10
Instrument Cluster	12
Catalytic Converter Cautions	14
Starting and Turning off the Engine	15
Driving Hints	16
MERCEDES-BENZ Maintenance System	18





## Instruments and Controls

*For more detailed descriptions see specified pages.*

- 1** Air volume control for side ventilation outlets (page 20)
- 2** Adjustable side ventilation outlets (page 20)
- 3** Adjustable air outlets (page 20)
- 4** Parking brake release (page 56)
- 5** Hood lock release (pages 68, 69)
- 6** Parking brake pedal (page 56)
- 7** Combination switch (page 43)
- 8** Exterior lamp switch (page 42)
- 9** Cruise control (page 59)
- 10** Instrument cluster (page 12)
- 11** Horn control, airbag
- 12** Steering lock with ignition/starter switch (page 41)
- 13** Slide lever for center ventilation outlets (page 20)
- 14** Rear window defroster switch (page 46)
- 15** Air recirculation switch (page 20)
- 16** Fanfare horn control switch
- 17** Hazard warning flasher system switch
- 18** Automatic antenna switch (page 53)
- 19** Rear passenger compartment lamp switch (page 47)
- 20** Automatic climate control (page 20)
- 21** Radio (page 49)
- 22** Ash tray with lighter (pages 45, 89)
- 23** Left front seat heater switch (page 32)
- 24** Right front seat heater switch (page 32)
- 25** Left power window switch group (page 48)
- 26** Adjusting lever for exterior mirror on front passenger side (page 44)
- 27** Loudspeaker-front to rear fader control
- 28** Right power window switch group (page 48)
- 29** Glove compartment, illuminated (only with key in steering lock positions 1 or 2)

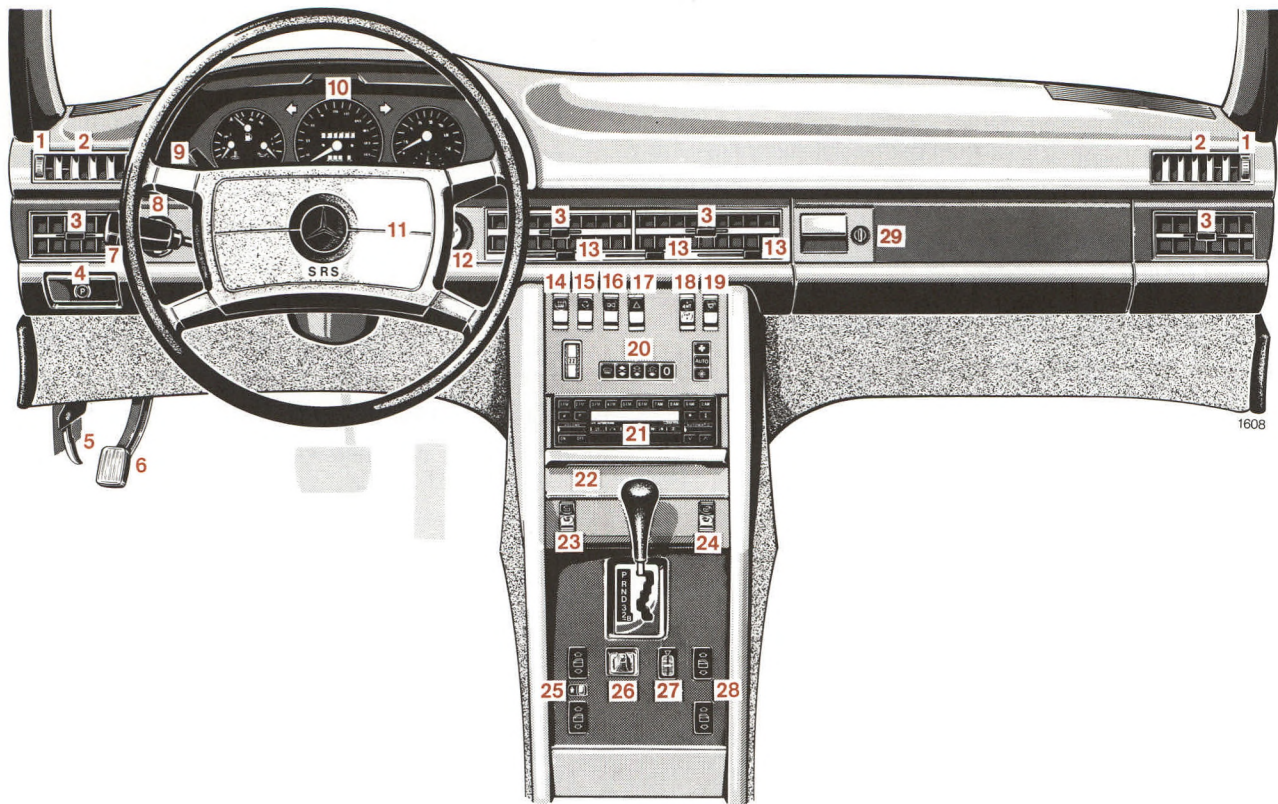



## Instrument Cluster

- 1** Economical driving indicator (ECONOMY).  
See page 60
- 2** Coolant temperature gauge  
Up to red marking: Maximum permissible temperature for an anticorrosion/antifreeze-blended fill protecting down to  $-30^{\circ}\text{C}$  ( $-22^{\circ}\text{F}$ ). See page 61
- 3** Fuel gauge with reserve warning lamp (yellow).  
See page 61  
Fuel reserve and capacity, refer to page 99 and last page
- 4** Oil pressure gauge (bar). See page 60
- 5** Turn signal indicator lamp, left (green)
- 6** Speedometer
- 7** Main odometer
- 8** Trip odometer
- 9** Turn signal indicator lamp, right (green)
- 10** Tachometer
- 11** Red marking on tachometer:  
Excessive engine speed
- 12** Electric clock
- 13** Knob for clock adjustment  
(press in for adjustments)
- 14** O<sub>2</sub>-Sensor malfunction indicator lamp (red):  
If the indicator lamp comes on, it indicates a malfunction in the O<sub>2</sub>-sensor circuit. The O<sub>2</sub>-sensor circuit should be checked by an authorized MERCEDES-BENZ dealer at the first opportunity.
- 15** Supplemental restraint system indicator lamp (red).  
See page 38
- 16** Antilock brake system (ABS) indicator lamp (yellow). See page 63
- 17** Exterior light failure indicator lamp (yellow).  
See page 61
- 18** Low windshield and headlamp washer fluid level indicator lamp (yellow). See page 61
- 19** Outside temperature indicator. See page 62
- 20** Low engine coolant level indicator lamp (yellow).  
See page 61
- 21** Low engine oil level indicator lamp (yellow).  
See page 60
- 22** Brake pad wear indicator lamp (yellow). See page 62
- 23** Brake warning lamp (red). See pages 56, 62
- 24** Charge indicator lamp (red). See page 60
- 25** High beam indicator lamp (blue)
- 26** Knob for instrument lamps and trip odometer  
Rotate knob: To vary intensity of instrument lamps  
Depress knob: To reset trip odometer



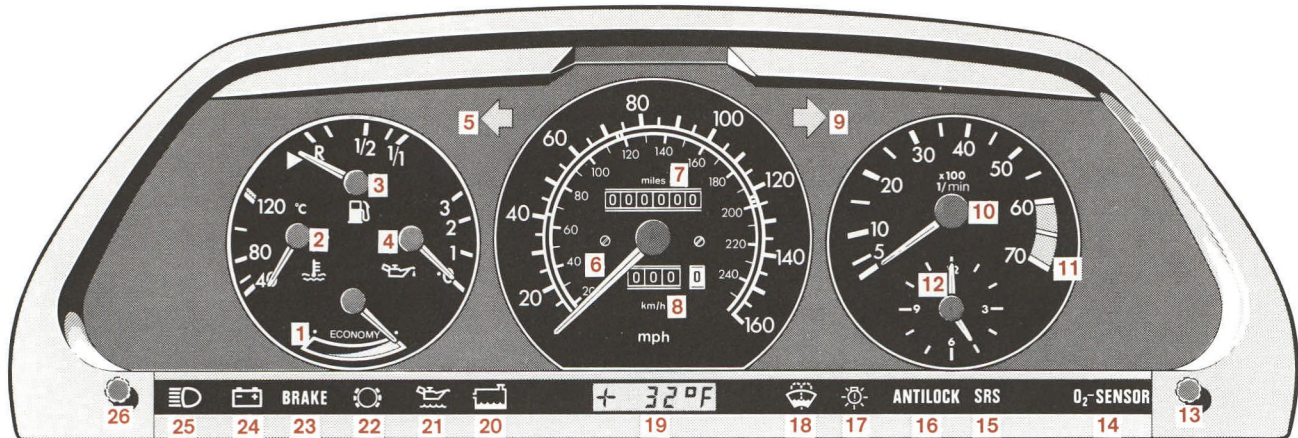

1395



### Catalytic Converter Cautions

Your MERCEDES-BENZ is equipped with monolithic catalytic converters, an important element in conjunction with the O<sub>2</sub>-sensor to achieve substantial control of the pollutants in the exhaust emissions. Keep your vehicle in proper operating condition by following our recommended maintenance instructions as outlined in your maintenance booklet.

### Caution!

To prevent damage to the catalytic converters, only use unleaded gasoline in this vehicle.

Should any noticeable irregularities in the engine operation occur, excessive unburned fuel may reach the converter causing it to overheat.

### Warning!

**As with any vehicle, do not idle, park or operate this vehicle in areas where combustible materials such as grass, hay or leaves can come into contact with the hot exhaust system, as these materials could be ignited.**

## Starting and Turning off the Engine

Engage parking brake and move the gear selector lever in either “P” or “N” position before starting the engine.

Turn key to steering lock position 2. The charge indicator lamp should come on.

### Cold Engine

Turn key in steering lock clockwise to the stop. Do not depress accelerator. Release key only when the engine is firing regularly.

At ambient temperatures of less than  $-18^{\circ}\text{C}$  ( $0^{\circ}\text{F}$ ), depress accelerator three times prior to starting.

### Hot Engine

Turn key in steering lock clockwise to the stop. Do not depress accelerator. If the engine has not fired after approx. 4 seconds, depress accelerator and continue cranking until the engine is firing regularly. Release key and back off accelerator.

At very high coolant temperatures the engine starting time can be shortened if the accelerator is depressed slowly at the beginning of the starting process.

## Turning off

Turn the key in steering lock to position 0 and only remove the key when the vehicle is at standstill.

If the coolant temperature is very high (e.g. after hard driving on mountain roads), do not shut off the engine immediately, allow it to run for 1–2 minutes at increased idle speed.

### Hints:

Due to the installed starter non-repeat unit, the key must be returned to steering lock position 0 before a new starting attempt is made.

Observe the oil pressure gauge immediately after starting the engine. In a very cold engine the oil pressure will only rise slowly, some time after the engine has started. Do not speed up the engine before pressure is registered on the pressure gauge.

The charge indicator lamp should go out as soon as the engine has started. Should too much fuel have entered the engine due to several unsuccessful starting attempts and the engine will no longer fire, depress the accelerator while starting. This should make the mixture combustible again. Back off the accelerator only when the engine is firing regularly.

In areas where temperatures frequently drop below  $-25^{\circ}\text{C}$  ( $-13^{\circ}\text{F}$ ), we recommend that a block heater is installed. Every MERCEDES-BENZ dealer will advise you on this subject.





## Driving Hints

### Power assistance

When the engine is not running, the brake and steering systems are without power assistance. Under these circumstances, a much greater effort is necessary to steer or stop the vehicle.

### Tires

Do not allow your tires to wear down too far. With less than 3mm ( $\frac{1}{8}$  in) of tread, the antiskid properties on a wet road are sharply reduced.

Depending upon the weather and/or road surface (conditions), the traction varies widely.

Specified tire pressures must be maintained. This applies particularly if the tires are subjected to high loads (e. g. high speeds, heavy loads, high ambient temperatures).

### Aquaplaning

Depending on the depth of the water layer on the road, aquaplaning may occur, even at low speeds. Avoid track grooves in the road and apply brakes cautiously in the rain.

### Tire friction

The safe speed on a wet or icy road is always lower than on a dry road.

You should pay particular attention to the condition of the road as soon as the prevailing temperatures fall close to the freezing point.

### Warning!

**If ice has formed on the road, tire traction will be substantially reduced. Under such weather conditions, drive, steer and brake with extreme caution.**

We recommend M + S radial-ply tires for the cold season. On packed snow, they can reduce your stopping distance as compared with summer tires. Stopping distance, however, is still considerably greater than when the road is wet or dry.

### Brakes

### Warning!

**When driving down long and steep grades, relieve the brakes by shifting into “3”, “2” or “B”. This helps prevent overheating of the brakes and reduces brake pad wear.**

After hard braking it is advisable to drive on for some time so the air stream will cool down the brakes faster.

### Warning!

**After driving in heavy rain for some time without applying the brakes or through water deep enough to wet brake components, the first braking action may be somewhat reduced and increased pedal pressure may be necessary. Be sure to maintain a safe distance from vehicles in front.**

The condition of the parking brake system is checked each time the car is in the shop for maintenance.

Between maintenance checks it is a good practice to apply the parking brake once or twice while driving at approximately 50 km/h (30 mph) on a dry road. Apply brake lightly until a slight drag on the wheels is felt. Keep applying brakes for about 10 seconds while pulling release handle out before releasing parking brake completely. This practice will keep the parking brake at maximum efficiency.

## Warning!

**The stop lamps will not come on when applying the parking brake only. Perform the procedure in the previous paragraph only when the road is clear of other traffic.**

All checks and maintenance work on the brake system should be carried out by an authorized MERCEDES-BENZ dealer.

If the parking brake is released and the brake warning lamp in the instrument cluster stays on, the brake fluid level in the reservoir is too low.

Brake pad wear or a leak in the system may be the reason for low brake fluid in the reservoir.

Have the brake system inspected at an authorized MERCEDES-BENZ dealer without delay.

Install only brake pads recommended by us.

If other than recommended brake pads are installed, the braking properties of the vehicle can be affected to an extent that the safety is substantially impaired.

## Parking

### Warning!

**To reduce the risk of personal injury as a result of vehicle movement, before leaving the vehicle always:**

- 1. Keep foot on brake pedal.**
- 2. Move the selector lever to position "P".**
- 3. Turn front wheels towards the road curb.**
- 4. Firmly depress parking brake pedal.**
- 5. Turn the key to steering lock position 0 and remove.**

### Winter Driving Hints

The most important rule for slippery or icy roads is to drive sensibly and to avoid abrupt acceleration, braking and steering action. Do not use the cruise control system under such conditions.

When the vehicle is in danger of skidding, move selector lever to position "N". Try to keep the vehicle under control by corrective steering action.

Road salts and chemicals can adversely affect braking efficiency. Increased pedal force may become necessary to produce the normal brake effect. We therefore recommend depressing the brake pedal repeatedly when traveling on salt-strewn roads at length. This can bring road salt impaired braking efficiency back to normal. A prerequisite is, however, that this is possible without endangering other drivers on the road.

If the vehicle is parked after being driven on salt treated roads, the braking efficiency should be tested as soon as possible after driving is resumed while adhering to the safety requirements.





## MERCEDES-BENZ Maintenance System

A maintenance booklet is included with your car listing all the maintenance jobs that must be carried out after the following mileages:

### Routine Maintenance

Inspection at  
1300–1600 km (800–1000 miles)

Lubrication Service every  
12 000 km (7500 miles)

Maintenance Service every  
24 000 km (15 000 miles)

Additional Work every  
48 000 km (30 000 miles)

For additional details refer to the Maintenance Booklet.

In the case of low mileage operation, the Maintenance Service must be carried out at least once every 2 years.

### Engine Oil and Filter Change

Required every 12 000 km (7500 miles), or at least once a year (fall) when using year-round multi-grade oil; otherwise at least twice a year (spring and fall).

For engine oil recommendations, see page 98.

### Severe Operating Conditions

In the case of severe operating conditions or heavy use mainly in city traffic or over short distances, frequent mountain driving, poor roads, dusty and muddy conditions, trailer operation, hard and sporty driving etc., it may be necessary to carry out maintenance work at shorter than normal intervals, as follows:

Engine: Oil change with filter change every 6000 km (3750 miles)

Automatic transmission: Fluid change without filter change every 24 000 km (15 000 miles).

Tires: Inspect

Air cleaner: Clean or replace element

### Special Maintenance Measures

**Brake fluid** should be replaced annually, preferably in the spring.

It is recommended to use only brake fluid approved by MERCEDES-BENZ. Do not mix different types of brake fluids.

**The coolant** should be checked for sufficient protection before the start of and during the hot and cold season.

Have the coolant (water/anticorrosion/antifreeze mixture) replaced at least every three years (see “Fuels, Coolants, Lubricants, etc.”).

### Maintenance Vouchers

Your authorized MERCEDES-BENZ dealer will certify in the maintenance booklet that all lubrication and maintenance services have been carried out at the correct intervals.

## Operation

Automatic Climate Control	20
Car Keys	25
Opening the Doors	26
Locking and Unlocking of Doors	26
Central Locking System	27
Anti-Theft Alarm System	28
Adjusting Power Seats, Front	29
Arm Rest (Front Seats)	31
Orthopedic Seat Backrest	31
Heated Seats	32
Arm Rest (Rear Bench Seat)	33
Head Restraints, Rear	33
Adjusting Power Seats, Rear	33
Adjusting Individual Rear Seats	34
Adjusting Telescoping Steering Column	34
Supplemental Restraint System – Seat Belts, Emergency Tensioning Retractors, Driver Airbag	35
Steering Lock	41
Exterior Lamp Switch	42
Combination Switch	43
Exterior Rear View Mirrors	44
Inside Rear View Mirror	44
Lighter	45
Sun Visors	45
Rear Window Defroster	46
Interior Lamps	47
Sliding Roof with Rear Pop-Up Feature	47
Power Windows	48
Shelf below Rear Window	48
Electronic Radio	49

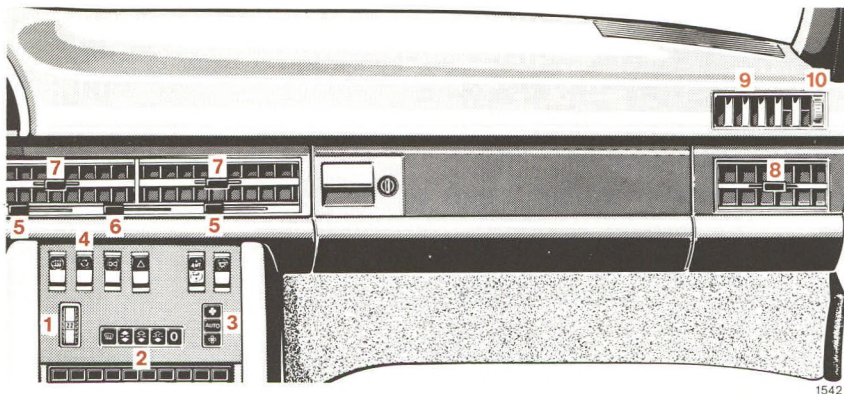

1542

### Automatic Climate Control

The engine must be running for the climate control system to operate.

- 1 Temperature selector
- 2 Pushbuttons for function selection (only press individually)

- Defrost
- Multi-Level
- Normal setting
- EC (Economy)
- Off (fresh air supply off)

- 3 Fan control buttons (only press individually)
  - Maximum fan speed
  - Automatic fan speed control
  - Minimum fan speed
- 4 Air recirculation switch
- 5 Slide lever for adjustable outlets 8
- 6 Slide lever for adjustable outlets 7
- 7, 8, 9 Adjustable air outlets
- 10 Air volume control for side ventilation outlets 9

For maximum operating efficiency, keep all windows and the sliding roof closed.

Heating, cooling, and air distribution within the vehicle's interior will be automatically controlled. This is accomplished with the temperature selector (1), the pushbuttons (2) and the fan control buttons (3).

The adjustable air outlets (7), (8) and (9) can be variably opened and closed, or moved to direct the flow of air as desired. The outlets (7) are opened and closed with slide lever (6), and outlets (8) with slide levers (5).

Move slide levers (5) and (6) towards the left to open, towards the right to close.

The air flow from the outlets (9) may be increased by rotating the control (10) up, and reduced by rotating down.

An air outlet in the rear passenger compartment console provides a variable flow of fresh outside air or cooled air. The air flow is increased by sliding the lever to the left and decreased by sliding the lever to the right.

To ensure efficient operation of the climate control system, the air outlets (7), (8) and (9) should not all be closed at the same time.



With the exterior lamps turned on (except standing lamps), the symbols on all buttons light up. Each button shines brighter when pressed.

Note:

The air conditioner removes considerable moisture from the air during operation. It is normal, if water drips on the ground through openings in the underbody.



### Temperature Selection (° C)

The desired temperature can be adjusted by turning the temperature selector. The selected temperature is reached as quickly as possible and maintained. A basic setting of 22° C (72° F) is recommended. To avoid undesirable temperature fluctuations, a set temperature should be readjusted in small increments.

To override the automatic climate control turn the temperature wheel to either extreme end position "MIN" or "MAX".

"MIN" (detent) = peak cooling performance.

The system operates with recirculated air, without additional fresh air.

"MAX" (detent) = maximum heating performance.

If button  is pressed with the temperature selector in the "MIN" or "MAX" position, it will run continuously at a high speed.



### Air Recirculation

Pressing the symbol-side of the air recirculation switch causes air to be recirculated without additional fresh air and the red indicator lamp to light up. After a while the air recirculation mode will switch off automatically, including the indicator lamp.

The air recirculation mode should be used with high or low outside temperatures, or to prevent dust or annoying odors from entering the car's interior. If the windows should fog up from the inside, the air recirculation should be shut off (press opposite side of symbol on switch). The red indicator lamp should then go out.

Note:

The air recirculation mode will not come on if button  is pressed.



### Function Setting

 Off

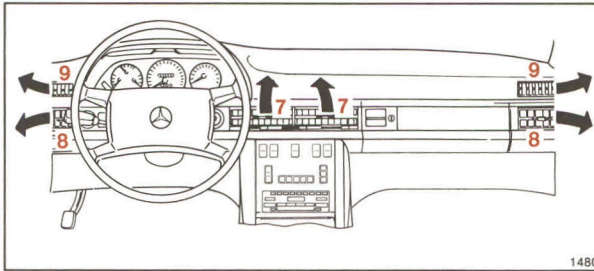
In this setting, the fresh air supply to the interior of the car is shut off, (to prevent entrance of odors, i. e. while driving through tunnels, etc. or to prevent the entrance of water from automatic car wash). Use this setting only temporarily while driving.



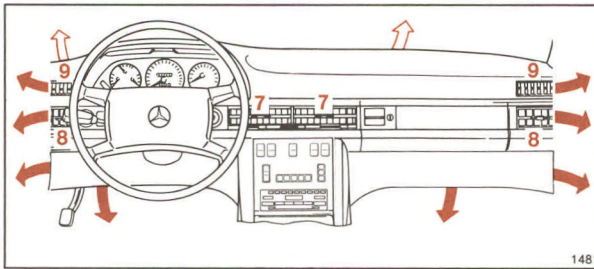

1480

-  Economy setting – Ventilation
-  Normal setting – Cooling



1481

-  Economy setting – Heating
-  Normal setting – Heating

 EC (ECONOMY) = Economical setting; the air conditioning compressor remains off.

In any other setting, the air conditioning compressor comes on with ambient temperatures above +5° C (+41° F).



As a fuel saving measure, we recommend this setting be used with cool outside temperatures, so that the air conditioning compressor remains off.

In the ventilation mode, air is emitted from outlets (7), (8) and (9).

In the heating mode, warm air is supplied primarily to the foot area. In addition, warm air is also supplied to the ducts in the front doors. Only enough warm air is supplied to the windshield and air outlets (8) and (9), to keep the glass defogged in normal weather conditions. In the heating mode, air will be emitted periodically from outlets (7), depending on the interior temperature.

With low outside temperatures, fan operation is cancelled until the engine coolant starts to warm up.

 Normal setting  
We recommend this setting with humid and warm outside conditions.

The setting  corresponds with setting  but, in addition, the air can be also cooled as necessary.



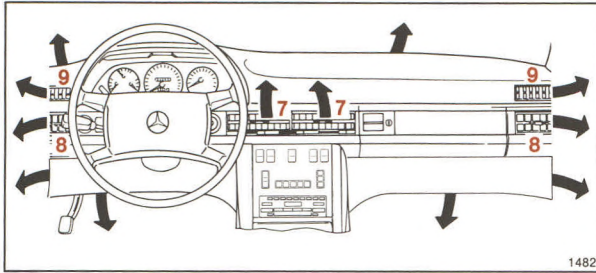

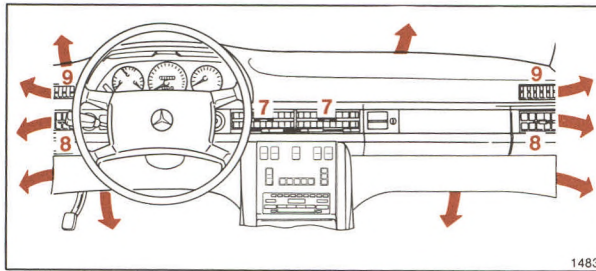

 Multi-Level ventilation – Cooling



 Multi-Level ventilation – Heating

### Multi-Level

This setting is used for clearing a fogged windshield. As soon as the windshield is clear, reset to  or .

In the heating mode, warm air is supplied to the windshield, foot area, air outlets (8) and (9), and to the ducts in the front doors. Additionally, warm air will be emitted periodically from outlets (7), depending on the interior temperature.

In the cooling mode, cool air is supplied to the windshield, foot area, front door ducts, and air outlets (7), (8) and (9).

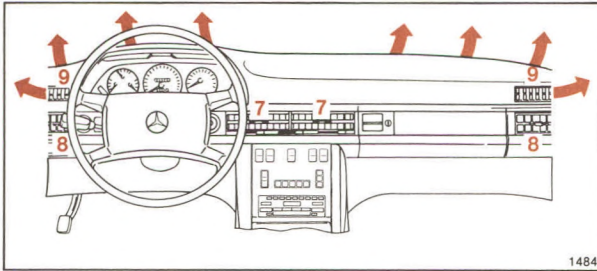

 Defrost

### Defrost

The maximum amount of heated air is directed to the windshield and side windows (outlets, 9). This setting overrides temperature and fan speed settings, and the air recirculation switch.

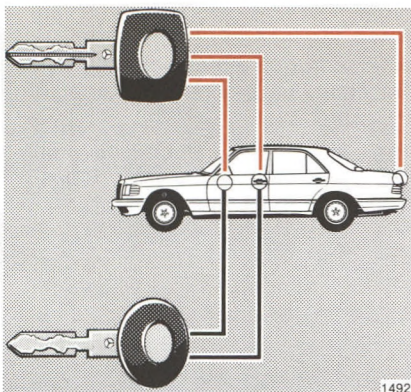

### Car Keys

Included with your vehicle are two master keys, one valet key and one flat (master) key.

**Master Key** – square head with a red dot – fits all locks on the car. Arms/disarms the anti-theft alarm system.

**Valet Key** – round head – fits only the door locks and the steering lock. This key is intended to be used whenever the car is left with an attendant. Be sure to lock glove compartment and trunk with the master key. The valet key cannot be used to de-activate the anti-theft alarm after the car is locked with the master key.

### Flat Key



The flat key with a red dot fits all vehicle locks. Arms/disarms the anti-theft alarm system. We recommend that you carry the flat key with you and keep it in a safe place so that it is always handy (e.g. in your wallet). Never leave the flat key in the vehicle.

### Obtaining Replacement Keys

Your car has a theft deterrent locking system. For security reasons, replacement keys can only be obtained via an authorized MERCEDES-BENZ dealer. Therefore, obtaining replacement keys requires considerable time.

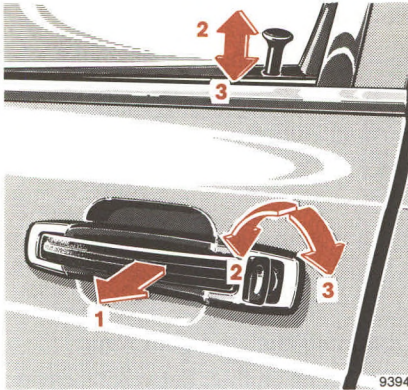

### Opening the Doors

From outside: pull handle outwards (1).

From inside: pull handle in door trim panel (4).

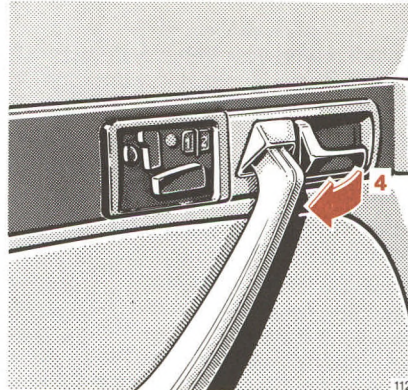

### Locking and Unlocking of Doors

From the outside: turn key.

From the inside: actuate door lock button.

- 2 Unlocking
- 3 Locking

When the rear door lock buttons are down, the rear doors cannot be opened from the outside or the inside. They can only be opened after pulling the buttons up.

The driver's door can be locked only if it is closed and the door lock has properly engaged.



## Central Locking System

The entire vehicle may be locked or unlocked with the central locking system:

- Using the master or valet key in either front door.
- Using the master key in the trunk lock.
- By pushing down or pulling up the interior door lock button at either front door.

The central locking system locks or unlocks all doors, trunk lid and fuel filler flap simultaneously.

### Doors

When you lock the car, all door lock buttons should move down. If any one stays up, the respective door is not properly closed. You should then unlock the car, open and reclose this door, and lock the car again.

### Note:

The central locking system can be engaged from the driver-side door lock button, provided the door is completely closed. It can also be engaged from the passenger-side if the ignition key is removed, or engaged in the steering lock without being turned (key in position 0).

If the car has been locked from the outside with the master key, the anti-theft alarm will come on if a door is opened from the inside, or if opened with the valet key.

### Trunk

To unlock the trunk with the central locking system, turn the master key in the trunk lock completely to the left and let it return to the normal position. Push in trunk lock button and open the trunk. To lock the trunk, turn the master key completely to the right and let it return to the normal position.

The trunk can remain locked while the central locking system is unlocked (e.g. while driving or when leaving the car in a situation where it must be driven using the valet key, but you wish the trunk to remain locked at parking lots, workshops, etc.). Turn the master key completely to the right and pull it out in that position. Now the trunk can only be unlocked with the master key by turning it back to the left.

### Important!

If the trunk is unlocked with the central locking system engaged, the doors and fuel filler flap will also be unlocked. After closing the trunk, the central locking system must again be engaged using the key!

### Note:

If the fuel filler flap cannot be opened, refer to “Unlocking of Fuel Filler Flap” (page 83).

## Anti-Theft Alarm System

The anti-theft alarm can be armed or disarmed with the master key (identified by red dot) by locking or unlocking either front door or the trunk.

### Operation

Once the alarm system has been armed, the exterior vehicle lamps will flash and the horn will sound intermittently when someone tries to:

- open a door
- open the trunk
- open the hood
- remove the radio
- switch on or bridge the ignition circuit
- step on the brake pedal
- raise the vehicle, i.e. towing away.

The alarm will last approximately 150 seconds in the form of blinking exterior lamps. At the same time an additional horn will sound intermittently for 60 seconds, pause for 30 seconds, and repeat for another 60 seconds.

The alarm will stay on even if the arming element (a door, for example) is immediately closed.

### Note:

If the radio is removed from its mounting when the anti-theft alarm is armed the radio will automatically be rendered inoperative!

To avoid setting off the alarm unintentionally, do not arm the alarm system in the following situations; e.g.: Auto ferry, auto train, when hitching/unhitching a trailer, or heavy loading/unloading. For this purpose use the valet key and not the master key for locking the vehicle.

### Special Function

To activate the anti-theft alarm from the trunk, turn the master key in the trunk lock completely to the right and pull it out in this position.

If you want the alarm system to be armed at the trunk only, turn the master key in the trunk lock completely to the right and pull it out in that position. Then disarm the rest of the vehicle by unlocking either front door with the master key. You can now lock or unlock the doors and filler flap, as well as start the engine, using the valet key. Do not give the master key to an unauthorized person. We recommend that you carry the flat key safely with you (e.g. in your wallet) so that it is always handy. This key has the same function as the master key.



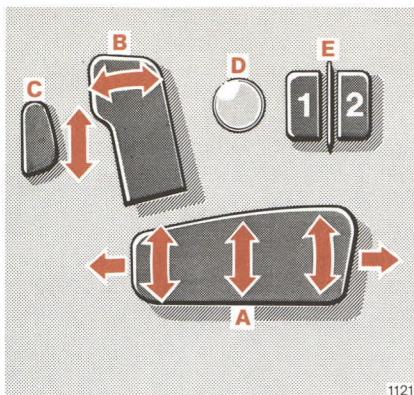

### Adjusting Power Seats, Front

The switches are located in each front door.

Turn key to steering lock position 1 or 2 (with the driver's or front passenger's door opened, the power seats can also be operated with the key removed or in steering lock position 0).

### Seat and Head Restraint Adjustment:

- A Seat cushion adjustment.
- B Seatback adjustment.
- C Head restraint adjustment.  
Adjust head restraint to support the back of the head approximately at ear level. The head restraint can also be turned forward by hand.

#### Note:

Your car is equipped with power head restraints, do not try to operate manually.

### Warning!

**Do not adjust the driver's seat while driving. Adjusting the seat while driving could cause the driver to lose control of the vehicle.**

**Never ride in a moving vehicle with the seat back reclined. The seat back and seat belts provide the best restraint, when the wearer is in an upright position and the belts are properly positioned on the body.**

Storing seat and head restraint positions in memory:

- D Memory button.
- E Position buttons "1" and "2".

Two sets of seat/head restraint positions may be programmed in memory. After the seat and head restraints are positioned, push memory button D, and within 3 seconds push position button "1". The second set of positions for the seat and head restraint can be stored by pushing position buttons D and "2".

Recalling seat and head restraint positions stored in memory:

To recall a seat/head restraint position, push position button "1" or "2" until seat/head restraint movement has stopped. For safety reasons, the seat/head restraint movement stops after releasing the position button.

### Caution!

Do not remove head restraints except when mounting seat covers. For removal refer to "Practical Hints". Whenever restraints have been removed be sure to reinstall them before driving.

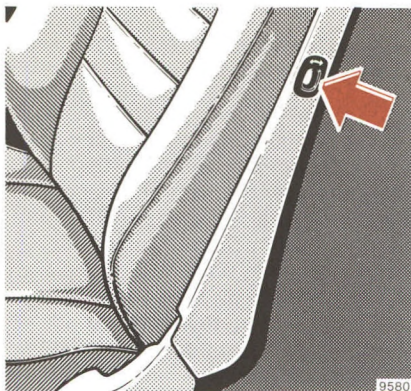

### Important!

Prior to operating the vehicle, the driver should adjust the seat height for proper vision as well as fore/aft placement and seat back angle to insure adequate control, reach, operation, and comfort. The head restraint should also be adjusted for proper height.

Both the inside and outside rear view mirrors should be adjusted for adequate rearward vision. Fasten seat belts. Infants and small children should be seated in a properly secured restraint system that complies with Federal Motor Vehicle Safety Standard 213.

All seat, head restraint, and rear view mirror adjustments as well as fastening of seat belts should be done before the vehicle is put into motion.

Coupé: For safety, when the doors are closed the backrests are locked by vacuum. The locks can be released by pushing the button (arrow). When the doors are opened the backrests can be folded forward without pushing the button.

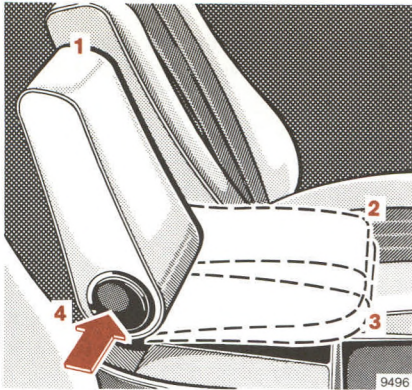

### Arm Rest (Front Seats)

The arm rest engages in 3 positions.

Position 1 = arm rest folded up.

Position 2 = for normally inclined seat back.

Position 3 = for extremely inclined seat back.

For downward adjustment of the arm rest, depress release button 4.

Note:

To move the arm rest between positions 1 and 2 it may be necessary to overcome a slight resistance.

### Warning!

The arm rest does not suffice as a child restraint system. In case of a frontal collision a child can be catapulted forward over the locked arm rest. Infants and small children should be seated in a properly secured restraint system that complies with Federal Motor Vehicle Safety Standard 213.

### Orthopedic Seat Backrest

Some models may be equipped with orthopedic seats. These seats have an inflatable air cushion built into the backrest to provide additional lumbar support. The amount of cushion height and curvature may be adjusted after turning the key to steering lock position 1 or 2.

The inflation pressure of the air cushion can be varied between position "0" = without pressure, and position "4" = maximum pressure, by changing the pressure regulator (1) setting.

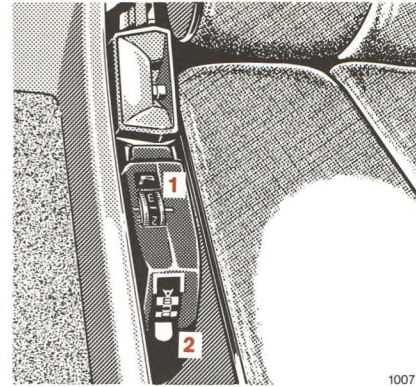

In addition, the cushion height may be changed to five different settings between position "A" = lowest setting, and "E" = highest setting, by varying the height regulator (2) adjustment.

If a driving trip is temporarily interrupted, the last cushion setting is retained in memory, and automatically adjusts the cushion to this setting when the trip is continued.



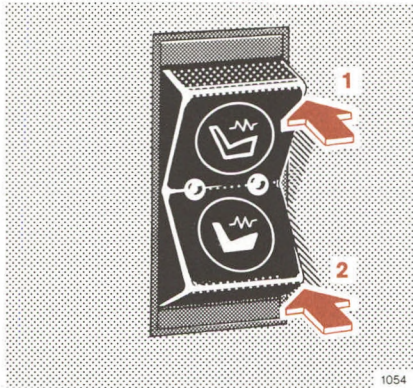

#### Heater operation:

Push in upper switch portion; position 1 = normal heater operation, one indicator lamp lights up.

Push in lower switch portion; position 2 = rapid heating, both indicator lamps light up.

After approximately 5 minutes in the rapid heating mode, the heater automatically switches to normal operation and only one indicator lamp will stay on.

#### Turning off heater:

If one indicator lamp is on, press in upper part of switch, position 1.

If both indicator lamps are on, press in lower part of switch, position 2.

The heater automatically turns off after approximately 30 minutes of operation.

#### Note:

When in operation, the seat heater consumes a large amount of power. It is advisable not to use the seat heater longer than necessary.

### Heated Seats

The front seat heaters can be switched on with the key in steering lock positions 1 or 2, the rear seat heaters only in steering lock position 2.

The switches for the front seats are located at the forward end of the center console, those for the rear seats are located in the rear doors.

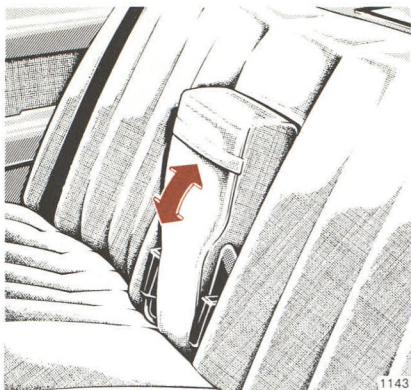

### Arm Rest (Rear Bench Seat)

When pulling out the arm rest by its strap, the seat belt buckles for the outboard seats swing out automatically.

For the removal of the rear seat cushion, see "Practical Hints".

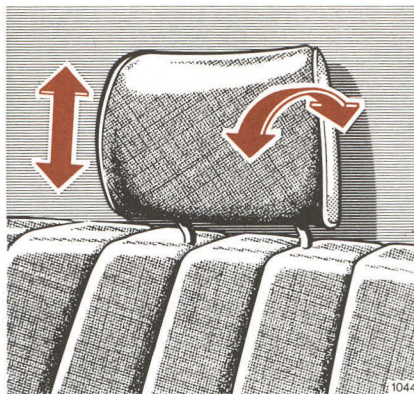

### Head Restraints, Rear

Adjust head restraint to support the back of the head approximately at ear level. Do not extend the head restraint past the stop.

For removal of head restraint refer to "Practical Hints".



### Adjusting Power Seats, Rear

Turn key to steering lock position 2. The rear seat can be adjusted in the fore/aft direction using the switch located in the rear door. The inclination of the seat back is altered together with the adjustment of the seat cushion.



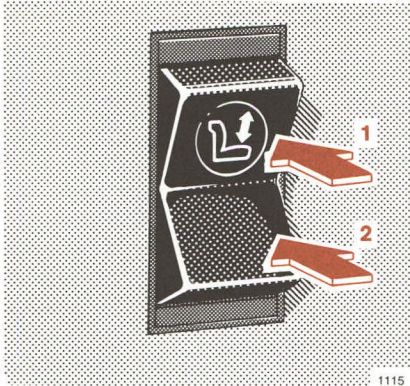

### Adjusting Individual Rear Seats

The switches are located on the console between the seats.

Turn key to steering lock position 2.

Press switches:

- 1 Upward seat cushion adjustment
- 2 Downward seat cushion adjustment
- 3 Forward seat cushion adjustment
- 4 Rearward seat cushion adjustment

The inclination of the seat back is altered together with the fore/aft adjustment of the seat cushion.

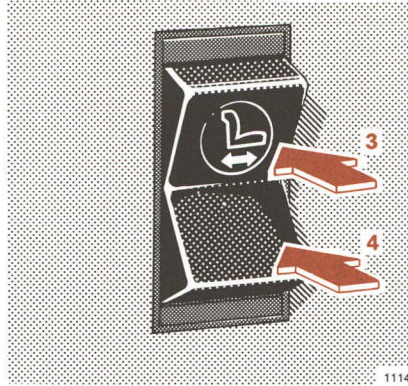

Note:

The seats can also be adjusted when the key is withdrawn or in steering lock position 1 or 0 provided the driver's door is opened.

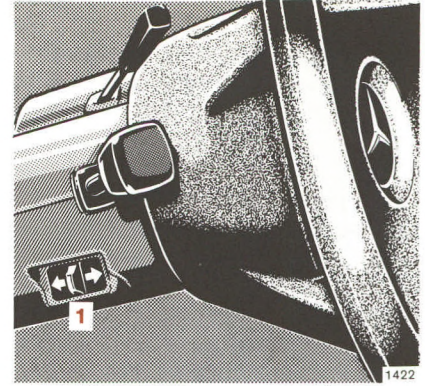

### Adjusting Telescoping Steering Column

Turn key to steering lock position 1 or 2 (with the driver's door opened, the telescoping steering column can be operated with the key removed or in steering lock position 0).

To lengthen or shorten the steering column, actuate the switch (1).

Note:

The steering wheel position is stored in memory with the seat and head restraint position.



### Supplemental Restraint System – Seat Belts, Emergency Tensing Retractors, Driver Airbag

#### Seat Belts and Emergency Tensing Retractor

Your vehicle is equipped with seat belts for all seats and emergency tensing retractors for front seats. The tensing retractors are located in each belt's inertia reel and become operationally ready with the key in steering lock position 1 or 2.

#### Important!

Laws in your state may require seat belt use.

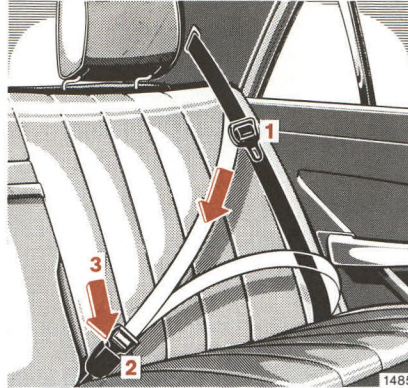

Seat belt warning buzzer and reminder lamp:

With the key in steering lock position 2, a warning buzzer sounds for a short time if the driver's seat belt is not fastened.

When someone enters the car the reminder lamp, located below the front interior/reading lamp, flashes for a short time to remind all occupants to fasten seat belts.

Fastening:

- Pull belt with latch plate (1) over shoulder and lap. Do not twist the belt doing this.
- Push latch plate (1) into buckle (2) until it clicks.

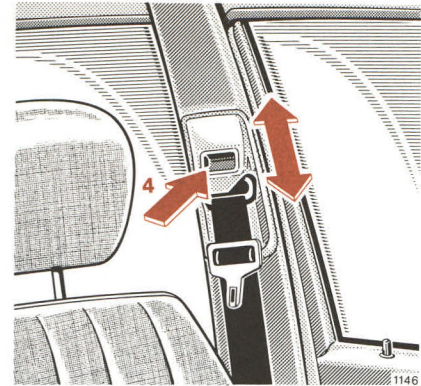

- 420 SEL, 560 SEL:  
Adjust front seat belts so the upper belt is located as near as possible to the middle of the shoulder (it should not touch the neck). For this purpose, push button (4) and raise or lower belt outlet (3 positions).
- 560 SEC:  
When the respective door is closed and the key is in steering lock position 2, the seat belt extender brings the belt forward within easy reach of the occupant. The seat belt extender returns to its rest position when the seat belt is buckled or when resistance to its extension is encountered (e.g., accidental occupant contact).



If the seat belt is not buckled within 30 seconds, the seat belt extender will return to its rest position.

This is also the case if the key is turned to steering lock position 1 or 0 or if the door is opened.

#### Emergency operation:

If the electrical system fails, the extender arm and belt can be manually pushed back into their rest position.

- The belt must be pulled snug and checked for snugness immediately after engaging it and during driving. If necessary, tighten the lap portion to a snug fit by pulling shoulder portion up.

On the coupe, the swivel fitting (mounted on the lower anchoring point to facilitate entering the vehicle) must point forward.

#### Unfastening:

- Push in the red button (3) in the belt buckle.
- The retractor should completely rewind the belt and latch plate (1).

#### Operation:

The inertia reel stops the belt from unwinding during sudden vehicle stops or when quickly pulling on the belt.

The emergency tensioning retractor tightens the seat belt upon severe frontal impacts within the shaded area shown on page 37.

The locking function of the reel may be checked by quickly pulling out the belt.

#### Lap belt for middle of rear seat:

Pull belt with latch plate (1) across the lap, press latch plate into buckle (2) until it clicks. The belt must not be twisted and must be tight.

To shorten the belt: With the latch plate engaged, pull the loose end of the belt.



To lengthen the belt: With the belt unfastened, turn the latch plate so that it is a little more than 90° to the belt, then extend the belt. Fasten the belt and shorten as stated above.

To disengage the belt, push red button (3) in buckle.

If the center seat is not occupied, the belt buckle and rolled-up seat belt can be stored in the space next to the rear arm rest (to the left or right of arm rest).

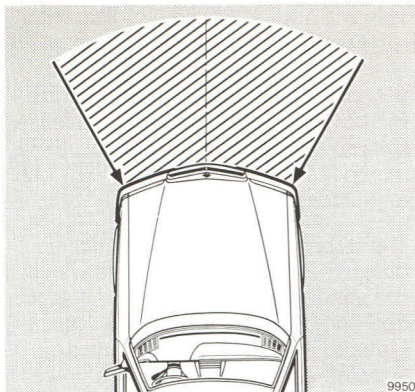

The emergency tensioning retractors are designed to activate only during severe frontal impacts within the shaded area shown. They tighten the belts in such a way that they fit more snugly against the body restricting as much as possible its forward movement.

In cases of less severe frontal impacts, such as roll-overs, side or rear collisions, or other accidents without severe frontal forces, the emergency tensioning retractors will not be activated. The driver and passengers will then be protected by the fastened seat belts and inertia reel in the usual manner.

#### **Warning!**

- **All occupants should wear seat belts at all times. Never wear the shoulder belt under your arm or otherwise out of position. Position the lap belt as low as possible around the hips (not the waist).**

- **Infants and small children should be seated in a properly secured child or infant restraint system.**
- **Seat belts should not be used for more than one person at a time.**
- **Belts should not be worn twisted.**
- **Pregnant women should select a seat with a lap-shoulder belt whenever possible. The lap belt should be positioned as low as possible around the hips, to avoid any possible pressure on the abdomen.**

For cleaning and care of the seat belts, see page 87.

For seat belt and emergency tensioning retractor safety rules, see page 39.

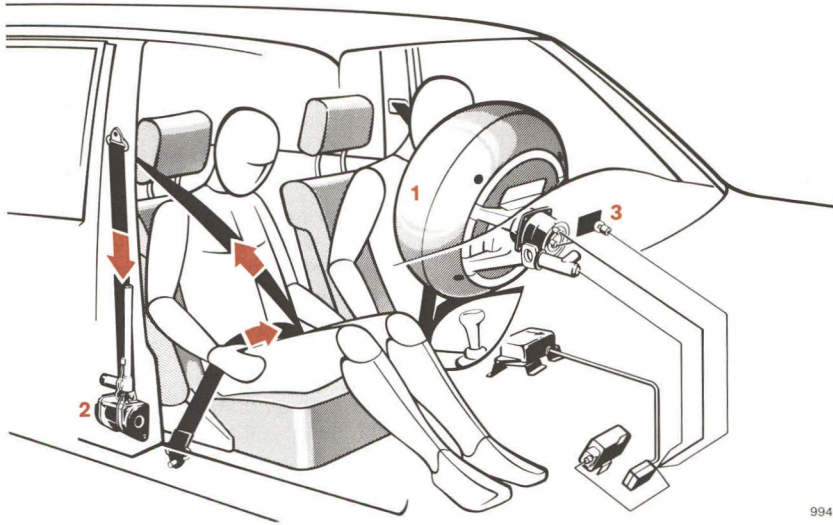

9949

### Driver Airbag

The airbag (1) is located in the steering wheel hub and, in conjunction with wearing the seat belts with emergency tensioning retractors (2), provides increased protection for the driver.

The operational readiness of the supplemental restraint system (airbag) is verified by the indicator lamp "SRS" (3) in the instrument cluster. With the key in steering lock position 1 or 2, the indicator lamp comes on for about 10 seconds then goes out. If it doesn't come on, doesn't go out, flickers on and off, or comes on while driving, the system is malfunctioning.

This will not cause the supplemental restraint system to be activated. However, we strongly recommend that you visit an authorized MERCEDES-BENZ dealer immediately to have the system checked; otherwise the "SRS" may not be activated in a severe frontal accident.

The airbag is designed to activate only in severe frontal impacts within the shaded area shown in the illustration on page 37. Only during these types of impacts will it provide its supplemental protection. The driver should always wear the seat belt, otherwise it is not possible for the airbag to provide its intended protection.

In cases of less severe frontal impacts, roll-overs, side or rear collisions, or other accidents without severe frontal forces, the airbag will not be activated. The driver and other passengers will then be protected by the fastened seat belts.



The activation of the “SRS” temporarily releases a small amount of dust from the driver airbag and all of the seat belt emergency tensioning retractors. This dust, however, is neither injurious to your health, nor does it indicate a fire in the vehicle.

The service life of the airbag extends to the date indicated on the sticker on the inside of the glove compartment door and on the radiator support in the engine compartment. To provide continued reliability after that date, it should be inspected by an authorized MERCEDES-BENZ dealer at that time.

### **Safety Guidelines for the Supplemental Restraint System – Seat Belts, Emergency Tensioning Retractor and Airbag**

#### **Warning!**

- **Damaged belts or belts that were highly stressed in an accident must be replaced and their anchoring points must also be checked. Use only belts installed or supplied by MERCEDES-BENZ.**
- **Do not pass belts over sharp edges.**
- **Do not make any modification that could change the effectiveness of the belts.**
- **An airbag or tensioning retractor that was activated must be replaced.**
- **No modifications of any kind may be made to any components or wiring of the “SRS”. This includes the installation of additional trim material, badges, etc. over the steering wheel hub and installation of additional electrical/electronic equipment on or near “SRS” components and wiring.**

- **Improper work on the system, including incorrect installation and removal, can lead to possible injury through an uncontrolled activation of the “SRS”. In addition, through improper work there is the risk of rendering the “SRS” inoperative. Work on the “SRS” must therefore only be performed by an authorized MERCEDES-BENZ dealer.**
- **When scrapping the airbag unit or emergency tensioning retractor, it is mandatory to follow our safety instructions. These instructions are available at every authorized MERCEDES-BENZ dealer.**

When you sell the vehicle we strongly urge you to give notice to the subsequent owner that it is equipped with an “SRS” by alerting him to the applicable section in the Owner’s Manual.



## Infant and Child Restraint Systems

Mercedes-Benz of North America recommends that all infants and children be restrained at all times while the vehicle is in motion.

## Important!

The use of infant or child restraints is required by law in most states.

Infants and children should be seated in a properly secured restraint system that complies with U.S. Federal Motor Vehicle Safety Standard 213. A statement by the seat manufacturer of compliance with this standard can be found on the instruction label on the restraint and in the instruction manual provided with the restraint.

When using any infant or child restraint system, be sure to carefully read and follow all manufacturer's instructions on installation and use.

## Warning!

**Infants and small children should never be held on the lap, nor should they share a seat belt with another occupant while the vehicle is in motion.**

This vehicle is equipped with tether anchorages for use with child restraints that have a top tether strap. Consult your local dealer for the exact location of these anchorages.

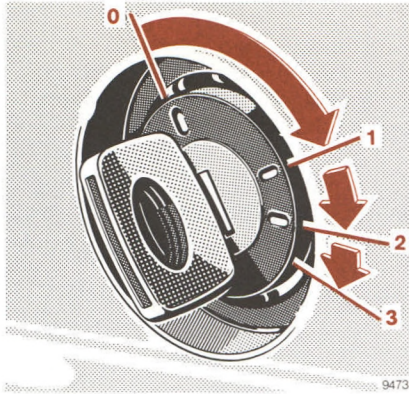

## Steering Lock

- 0 Steering is locked when the key is withdrawn and the steering lock is engaged. The key can be withdrawn only in position 0.

### Warning!

**Do not remove key from the steering lock while the vehicle is in motion as this will cause the engagement of the steering lock thus rendering the vehicle inoperable.**

- 1 Steering is unlocked.  
(If necessary, move steering wheel slightly to turn the key clockwise to position 1.)
- 2 Driving position.
- 3 Starting position.

For starting and turning off the engine, refer to page 15.

### Notes:

The following items can be operated with the key in steering lock position 1:

Wiper, windshield washer, headlamp cleaning system (only in exterior lamp switch positions 1 or 2), headlamp flasher, lighter, glove compartment lamp, radio, sliding roof, rear window defroster, power windows, front power seats, front heated seats, orthopedic seat backrest, telescoping steering column.

A warning buzzer sounds when the driver's door is opened with the key in steering lock position 1 or 0.

With the engine at idle speed, the charging rate of the alternator (output) is limited.

It is therefore recommended to turn off unnecessary electrical consumers while driving in stop and go traffic. This precaution helps to avoid draining of the battery.

Unnecessary strain on the battery and charging system may be minimized by turning off the following power consumers, for example:

Heated seats, rear window defroster.

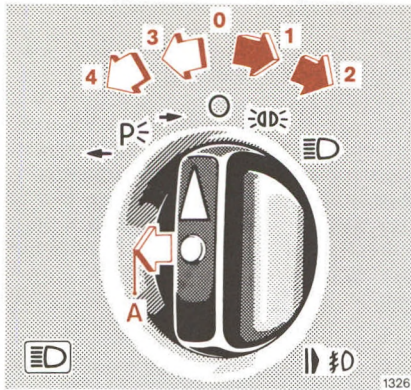

### Exterior Lamp Switch

- 0 Off-position
- 1 Parking lamps (includes side marker lamps, taillamps, license plate lamps, instrument panel lamps)
- 2 Same as pos. 1 plus headlamps
- 3 Standing lamps, right
- 4 Standing lamps, left
- A Turn to position 2 and pull out to first stop = same as position 2 plus fog lamps.

### Standing lamps

When the vehicle is parked on the street the standing lamps (right or left side parking lamps) can be turned on, making the vehicle more visible to passing vehicles.

The standing lamps can only be operated with steering lock in position 0 or 1.

### Notes:

With the key removed and the driver's door open, a warning buzzer sounds if the vehicle's exterior lamps are not switched off (standing lamps excepted).

Fog lamps will only operate together with low beam headlamps. Fog lamps are turned off automatically when the exterior lamp switch is returned to off-position.



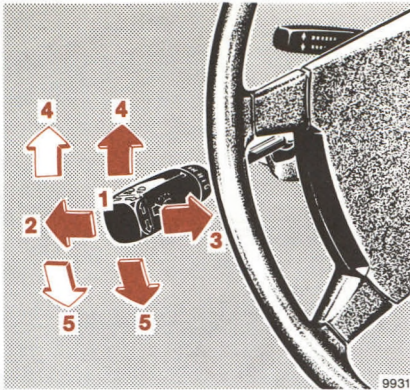

### Combination Switch

- 1 Low beam (with exterior lamp switch turned to position 2)
- 2 High beam (with exterior lamp switch turned to position 2)
- 3 High beam flasher (high beam available independent of exterior lamp switch position)
- 4 Turn signals, right
- 5 Turn signals, left

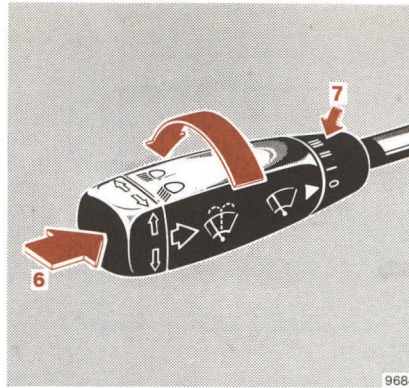

- 6 Control for
  - windshield washer system
  - headlamp cleaning system (will work only with exterior lamp switch in position 1 or 2)

When the washer system is activated, the wipers also operate for a limited time.

- 7 Windshield wiper speeds
  - 0 Windshield wiper switched off
  - I Intermittent wiping
  - II Normal wiper speed
  - III Fast wiper speed

### Note:

If one of the turn signals fails, the turn signal indicator system flashes and sounds at a faster rate than normally. In addition, the lamp failure indicator will come on.

For the overload protection for the windshield wiper motor, see page 83.

To operate the turn signals, move the combination switch past the point of resistance (up or down). The switch is automatically cancelled when the steering wheel is returned through a large enough angle.

To signal minor directional changes, such as changing lanes on a highway, move combination switch position only to the point of resistance and hold it there.

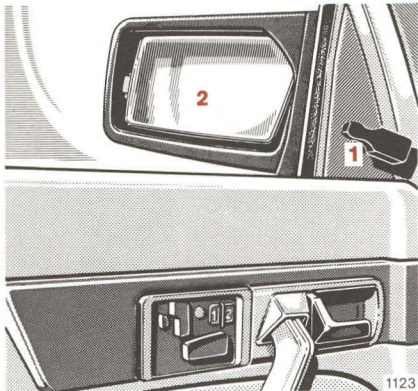

### Exterior Rear View Mirrors

The exterior mirrors have electrically heated glass. The heater switches on and off automatically, depending on outside temperature.

Driver's side:

The exterior mirror (2) can be adjusted from inside the vehicle by moving adjusting lever (1) in the desired direction.

Passenger side:

The passenger side exterior mirror is convex (curved surface). Exercise care when using the passenger side mirror. See warning imprint on mirror.

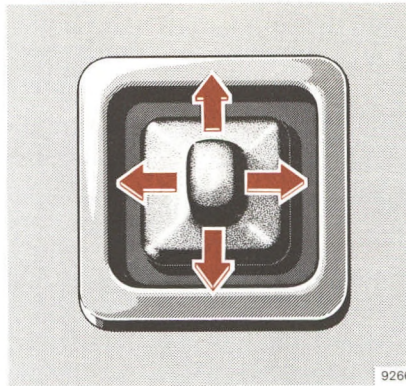

To adjust the mirror:

Turn key to steering lock position 2. The exterior mirror can be adjusted using the switch. Adjust the mirror so you can just see the side of your vehicle in the portion of the mirror closest to the car.

Note:

If the mirror housing is forcibly pivoted from its normal position, it must be repositioned manually by applying firm pressure until it snaps into place.

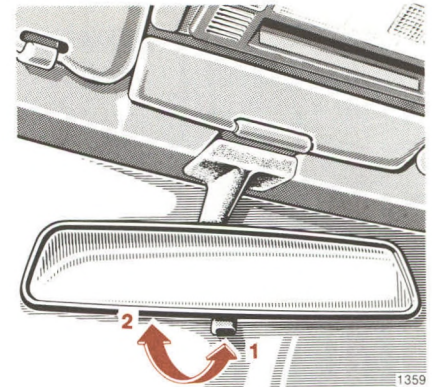

### Inside Rear View Mirror

The mirror can be tilted to the anti-glare night position by means of the lever at its lower edge.

1 = Normal position  
2 = Anti-glare night position.

Use your inside mirror to determine the size and distance of objects seen in the convex mirror.



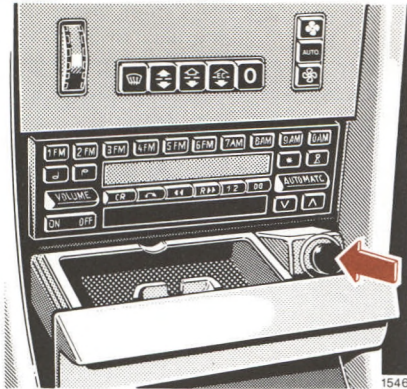

### Lighter

Turn key to steering lock position 1 or 2.

Press in lighter; it will pop out automatically when hot.

### Warning!

**Do not touch heating element or sides of lighter, hold at knob only.**

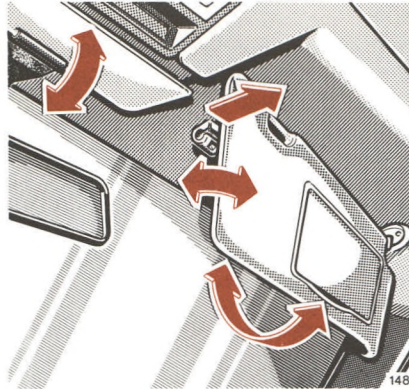

### Sun Visors

Swing sun visors down to protect against sun glare.

If sunlight enters through a side window, disengage visor from inner mounting and swing to the side. From this position, the visor can slide forward and backward on its shaft.

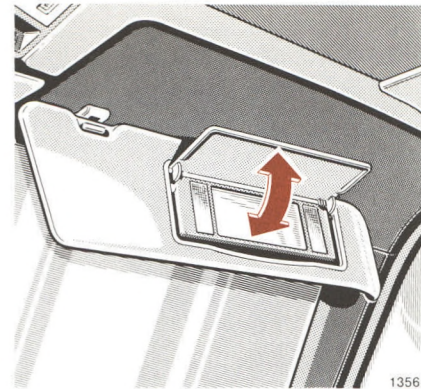

### Vanity mirror:

With the visor engaged in its inner mounting, the lamp can be switched on by opening the cover.

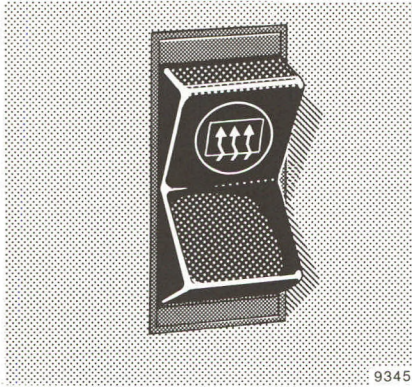

### Rear Window Defroster

With engine running, press symbol side of rocker switch to turn on, bottom to turn off.

When activating the rear window defroster, the indicator lamp inside the switch will come on.

#### Note:

The rear window defroster uses a large amount of power. To keep the battery drain to a minimum, turn off the defroster as soon as the window is clear. The defroster is automatically turned off after a maximum of 20 minutes of operation. Heavy accumulation of snow and ice should be removed before activating the defroster.

If several power consumers are turned on simultaneously, or the battery is only partially charged, it is possible that the defroster automatically turns itself off. When this happens, the indicator lamp inside the switch starts blinking. As soon as the battery has sufficient voltage, the defroster automatically turns itself back on.



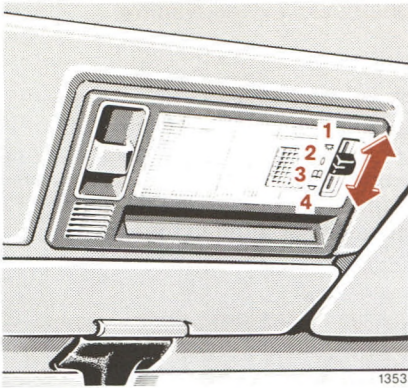

1353



9234

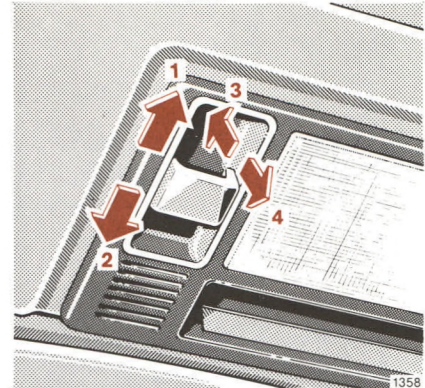

1358

### Interior Lamps

The switch for the front lamp (combination interior and reading lamp) has 4 positions.

Position 1: Interior and reading lamp switched on continuously.

Position 2: Interior and reading lamp switched off continuously.

Position 3: Reading lamp switched on continuously.

Position 4: Interior lamp is switched on and off (delayed) by the front door contact switches.

The rear courtesy lamp is switched on and off by the rear door contact switches or by the rocker switch on the instrument panel.

The reading lamps in the rear passenger compartment are switched on and off by a switch in each lamp.

### Sliding Roof with Rear Pop-Up Feature

Turn key to steering lock position 1 or 2.

- 1 Slide switch backward = to slide roof open.
- 2 Slide switch forward = to slide roof closed.
- 3 Press switch at rear = to raise roof at rear.
- 4 Pull switch at rear = to lower roof at rear.

The sliding roof can be opened or closed manually should an electrical malfunction occur (see page 83).

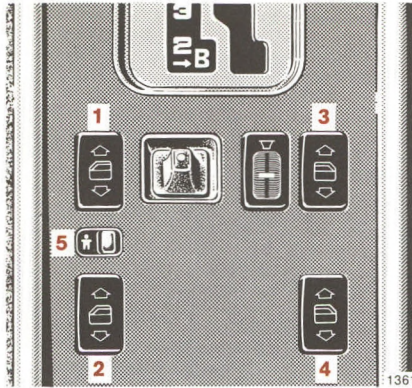

### Power Windows

Switch group for power windows:

- 1 left, front
- 2 left, rear
- 3 right, front
- 4 right, rear
- 5 Safety switch

The power windows can be operated with the key in steering lock position 1 or 2.

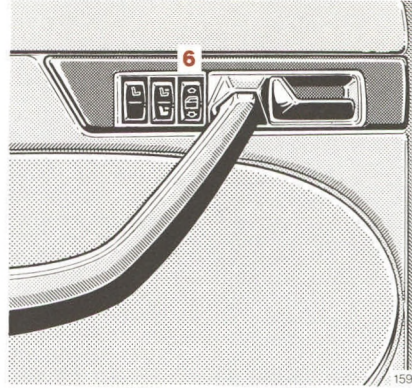

### Shelf below Rear Window

#### Warning!

The shelf below the rear window should not be used to carry objects. This will prevent such objects from being thrown about and injuring vehicle occupants during an accident or sudden maneuver.

All four windows can then be operated using the switches in the center console. The rear door windows can also be operated using the switches (6) in each rear door panel. If inadvertent operation of the rear windows (for instance by children) is to be prevented, push safety switch (5) to the right (symbol becomes visible).

#### Warning!

**When leaving the car always remove the key from the steering lock. Do not leave children unattended in the vehicle. Unsupervised use of power windows can cause serious personal injury.**



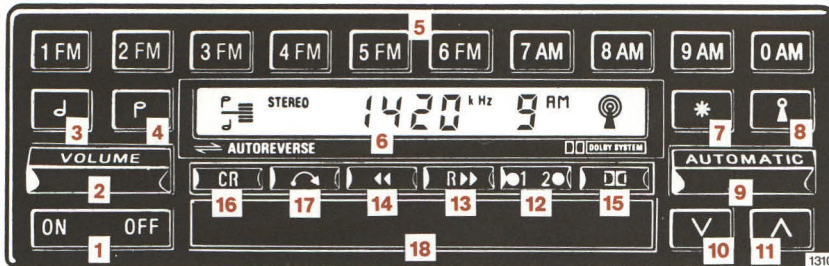

## Electronic Radio

### Pushbutton Functions

- 1 On/Off button **ON OFF**
- 2 Volume control **VOLUME**
- 3 Bass control **B**
- 4 Treble control **T**
- 5 Pushbuttons for AM/FM band selection, station frequency selection, station storage **1 FM** through **0 AM**
- 6 Digital display for station frequency (a), station pushbutton number (b), AM/FM band (c), stereo indicator (d), tone setting indicator (e), tuning sensitivity indicator (f)
- 7 Function control
- 8 Tuning sensitivity
- 9 Automatic station seeker bar
- 10 Manual tuning **▼** (decreasing station frequency)
- 11 Manual tuning **▲** (increasing station frequency)
- 12 Cassette track selector and track indicator **1 2**
- 13 Fast tape rewind **R▶▶**
- 14 Fast tape forward **◀◀**
- 15 Dolby\* noise reduction **DD**
- 16 Tape selection **CR**
- 17 Cassette eject **⤴**
- 18 Cassette door

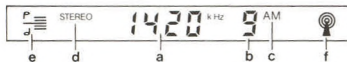

\* Dolby and the double-D symbol are trademarks of Dolby Laboratories Licensing Corporation. Noise reduction system manufactured under license from Dolby Laboratories Licensing Corporation.

## To turn the radio ON

Press “ON” side of **ON OFF** button. The radio will begin operating on the last station, volume and tone setting stored before the last turn off.

The system can also be turned on by inserting a tape cassette through the cassette door.

## To turn the radio OFF

Press the “OFF” side of the **ON OFF** button.

## Volume adjustment

To reduce volume, press volume button **VOLUME** downward; to increase volume, press volume button **VOLUME** upward.

A fader control, installed in the center console, allows for balancing the sound level between the front and rear speakers.

## To adjust the tone characteristic

Base and treble can be adjusted independently.

To set the radio to a "flat" tone setting (bass and treble at mid-range setting), briefly press both tone controls **J** **P** simultaneously.

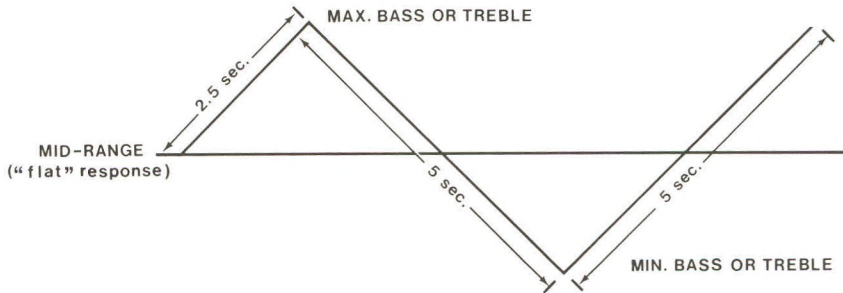

Upon pressing either tone button, the tone level for that function (either bass **J** or treble **P**) will begin increasing. It stops increasing when the button is released or when the maximum tone level is reached (approx. 2.5 seconds).

After reaching the maximum tone level, the tone control will stay at that level unless the tone button is released and pressed again, at which point the tone level will start decreasing. It will stop decreasing when the button is released or when the minimum tone level is reached (approx. 5 seconds).

After reaching the minimum tone level, the tone control will stay at that level unless the tone button is released and pressed again. After pressing the tone button again the tone level will begin to increase and the cycle is repeated.

Adjustments made to the tone characteristics can be observed on the tone setting indicator in the display.

Note: It takes approx. 5 seconds to go from minimum tone level to maximum tone level.

## To select AM or FM

Press any of the buttons marked **1 FM** through **6 FM** to tune the radio to the FM band.

Press any of the buttons marked **7 AM** through **0 AM** to tune the radio to the AM band.

The selected wave band is shown in the digital display.

## To tune in a station

Stations can be tuned in by using automatic seek, direct frequency tuning, manual tuning, or by preset push-buttons. The frequency of the station selected is indicated on the digital display.

## Automatic station seeker



Switch to the wave band desired by pressing any of the following buttons: for FM, buttons **1 FM** through **6 FM**, for AM, buttons **7 AM** through **0 AM**.

By pressing the automatic station seeker bar **AUTOMATIC** upward the radio will seek stations in ascending frequencies, by pressing down it will do so in descending frequencies. The direction of automatic seeking can be reversed by pressing the bar **AUTOMATIC** in the respective direction. In order to arrive at a desired station without stopping, the bar must be held in the desired direction.



## Tuning sensitivity button

By pressing the tuning sensitivity button  once or twice, you can select the desired sensitivity level of the automatic station seeker. The sensitivity indicator shows the selected sensitivity level:

-  = least sensitive (the automatic seeker only stops at strong stations)
-  = average (the automatic seeker stops at strong and moderate strength stations)
-  = most sensitive (the automatic seeker also stops at weak stations)

When switched off, the radio returns to the “least sensitive” level.

## Direct frequency tuning

In order to select a station with a known frequency, select the wave band (AM or FM), press the function control button  and then enter the frequency by pressing the corresponding pushbuttons.

Example:

	FM 98.5 MHz	AM 1050 kHz
Press any button marked	 through 	 through 
Press the function control button		
Enter frequency by pressing	  	   

When tuning a frequency directly, the number of the pushbutton is not displayed on the panel. The wave band is indicated by showing “MHz” for FM or “kHz” for AM.

Note:

All AM stations have allocated frequencies ending with a “0”.

All FM stations have allocated frequencies ending with an odd (uneven) digit after the decimal point.



Broadcasters sometimes may not give their exact frequency but the next closest whole number.

US radio frequency ranges:

AM 540–1600 kHz

FM 88.1–107.9 MHz





**Manual tuning** (used to fine tune a station or for manual scanning)

After selecting the desired AM or FM wave band, press the manual tuning button  (decreasing station frequency) or  (increasing station frequency).

The frequency will increase or decrease respectively in increments of 0.1 MHz for FM or 1.0 kHz for AM. Release the button when the desired station is tuned in.

Please note: It is recommended that manual tuning operations be performed by the driver while the vehicle is not in motion.

## Pushbutton tuning

Six FM stations and four AM stations can be stored in memory and recalled by pressing the appropriate buttons marked  through  for FM or  through  for AM stations.

## To store stations in memory

Any FM station can be stored on any button marked  through  by first tuning in the desired station, depressing the button desired and holding it until the display has changed from the “old” setting to a “blank” and then to the new station to be stored.

Showing the “old” setting first allows for reconsideration of the decision to store. If it is desirable to leave the “old” station in memory rather than exchanging it with the “new” one, quickly release the button. The “old” station will remain in memory.

Any AM station can be stored similarly on any button marked **7 AM** through **0 AM**.

### Stereo reception

The stereo indicator **STEREO** lights up if a stereo program in the AM or FM band is received.

Note: Since some AM stereo broadcasting is not compatible with your car radio reception capabilities, you may experience limited AM stereo reception in some areas. The radio receives AM stereo programs which are broadcast via the C-Quam AM stereo system.

The radio is equipped with an automatic stereo/mono switch that electronically switches to mono for clear reception if a weak signal is received.

The stereo indicator will remain lit even if the receiver has changed to the mono mode and will turn off at an antenna signal considered insufficient to provide acceptable reception quality.

Note: Although FM is normally static free, reception quality can be limited by geographic and atmospheric conditions, station strength and distance from transmitter. Buildings or other obstructions can cause momentary static, flutter or station swapping. If good reception cannot be obtained, tune to a stronger station.

### Tape cassette playback

It is recommended to use only good quality cassettes with a playback time of not more than 90 minutes (C 90).

To start playback, insert a cassette (tape side first, side “1” or “A” facing up) through the cassette door. Push the cassette in until it is locked in its playing position.

When the end of one playing side is reached, the unit switches automatically to reverse for playing the second track.

The tape track can be selected by depressing the cassette track button **1 2**. The built-in indicators show which track of the cassette the unit is playing back.

To stop playback, press the eject button **EJECT**. The unit will automatically eject the cassette and switch to radio reception.

For fast tape rewind press the fast rewind button **R**. The button will lock into position until the end of the tape is reached or until the eject button **EJECT** or fast forward button **F** is activated.

Accordingly, for fast forward of the tape, press the fast forward button **F**.

To replay cassettes recorded using the Dolby B noise reduction system, the Dolby NR button **NR** should be pressed in. This reduces tape hiss.

When the radio is turned off by pressing the “OFF” side of the **ON OFF** button or by turning the key to steering lock position 0, the cassette will automatically be ejected.

### Tape equalization

For good reproduction quality it is necessary to adjust the tape player for the particular type of tape being used. Press the CR button **CR** in for cassettes using CrO<sub>2</sub> (chromium dioxide) tape. For all other types of tapes (i. e., ferric oxide, iron, etc.) the CR button **CR** should be out.



## Care and maintenance

To avoid deterioration of the tone quality, clean the tape head with the special cleaning tape available through your authorized MERCEDES-BENZ dealer.

## Radio anti-theft protection

Removal of the radio with the vehicle anti-theft alarm armed will render the radio inoperative indicated by a dashed line across the display.

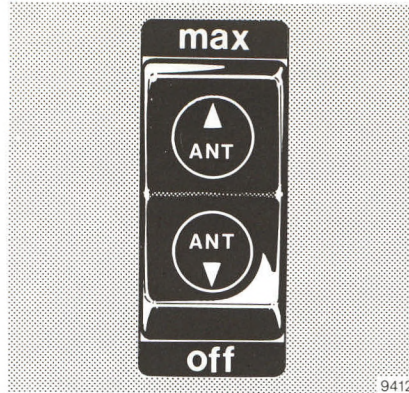

## Automatic Antenna

The antenna switch can be actuated with the radio switched on and the key in steering lock positions 1 or 2.

- If the antenna switch is in the center position, the antenna extends automatically to medium height,

- if the antenna switch is engaged in the "max." position, the antenna extends fully,
- if the antenna switch is engaged in the "off" position, the antenna will not extend or will retract completely.

The height of the antenna can be adjusted to any intermediate position by actuating the antenna switch:

- If the antenna switch is in the center position, the antenna will extend to medium height. The antenna can be further extended or retracted to any height by rocking the switch (not engaging it).
- If the antenna is to be retracted, e.g. going through car wash, etc., engage switch in "off" position.

When the key is turned to steering lock position 0 or the radio is turned off, the antenna will retract completely.





## Driving

Parking Brake	56
Starting and Shifting Gears	56
Cruise Control	59
Engine Oil Consumption	60
Economical Driving Indicator (ECONOMY)	60
Charge Indicator Lamp	60
Oil Pressure Gauge	60
Low Engine Oil Level Indicator Lamp	60
Exterior Light Failure Indicator Lamp	61
Fuel Reserve Warning Lamp	61
Coolant Temperature Gauge	61
Low Engine Coolant Level Indicator Lamp	61
Low Windshield and Headlamp Washer Fluid Level Indicator Lamp	61
Outside Temperature Indicator	62
Brake Pad Wear Indicator Lamp	62
Brake Warning Lamp	62
ABS-Brake System (Antilock Brake System)	63
Emission Control	64
Traveling Abroad	64
Winter Driving	65
Tire Chains	65

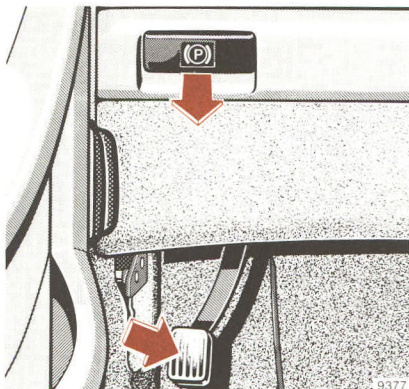

### Parking Brake

To engage, depress parking brake pedal. When the key is in steering lock position 2, the brake warning lamp in the instrument cluster should come on (function check for brake warning lamp).

To release the parking brake, pull handle on instrument panel. The brake warning lamp in the instrument cluster should go out.

### Starting and Shifting Gears

The automatic transmission selects individual gears automatically, dependent upon selector lever position, vehicle speed and accelerator position.

#### Warning!

**Keep driver's foot area clear at all times. Objects stored in this area may impair pedal movement.**

#### Driving:

Shift selector lever to the desired driving position only when the engine is idling and the service brake is applied. Do not release the brake until ready to drive. The vehicle may otherwise start creeping when the selector lever is in a driving position.

Test the brakes shortly after driving off. Perform this procedure only when the road is clear of other traffic.

Warm up the engine smoothly. Do not place full load on the engine until the operating temperature has been reached.

When starting off on a slippery surface, do not allow one driving wheel to spin for an extended period.

#### Accelerator position

Partial throttle = early upshifting = normal acceleration.

Full throttle = later upshifting = maximum acceleration.

Depressing the accelerator beyond full throttle to kickdown position means downshifting to the next lower gear and thereby increasing acceleration. If you ease up on the accelerator after having attained the desired speed, the transmission will shift up again.

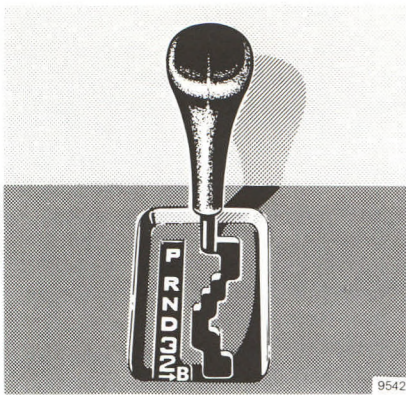

### Selector Lever Positions

The automatic gear shifting process can be adapted to specific operating conditions using the selector lever.

- “P” Parking lock.  
The parking lock is an additional safeguard to the parking brake when parking the vehicle. Engage only with the car stopped.
- “R” Reverse gear.  
Shift to reverse gear only with the car stopped.
- “N” Neutral.  
No power is transmitted from the engine to the rear axle. When the brakes are released, the vehicle can be moved freely (pushed, towed or tow-started). Do not engage “N” when driving except when the vehicle is in danger of skidding (e. g. on icy roads, see page 17).
- “D” Drive.  
Automatic upshifting to top gear. Position “D” affords optimum driving characteristics under all normal operating conditions.
- “3” Upshift to 3rd gear only. Suitable for medium range up or downgrades.
- “2” Upshift to 2nd gear only. For driving in mountainous regions. Since transmission will not shift up further, this gear selection will make use of the engine’s braking power.
- “B” In this position, the engine’s braking effect is utilized while descending steep or lengthy downgrades, especially with a trailer. Use this position only below 60 km/h (40 mph).

## Important!

Do not exceed the engine speed limits for individual gear selections, which are indicated by marks on the speedometer.

Do not attempt downshifting to a lower gear (braking effect) unless the speedometer needle is below the speed-limit-mark of that particular gear range. Over-revving could result in damage to the engine.

On slippery road surfaces, it is not recommended to downshift in order to obtain braking action. This could result in rear wheel slip and reduced vehicle control.

## Trailer operation

To prevent the engine from laboring at low RPMs, do not allow the engine speed to drop too low on uphill gradients. Depending on the degree of the incline, shift selector lever to positions "3" or "2" early enough to maintain engine RPMs within the best torque range.

## Stopping

For brief stops, e. g. at traffic lights, leave the transmission engaged and control vehicle with the service brake.

For longer stops with the engine idling, shift into "N" or "P".

When stopping the car on a slope, do not hold it with the accelerator, use the brake. This avoids unnecessary transmission heat-up.

## Maneuvering

To maneuver in tight areas, e. g. when pulling into a parking space, control the car speed by gradually releasing the brakes.

Accelerate gently and do not pump the accelerator. To rock a car out of soft ground (mud or snow), alternately shift from forward to reverse, while applying partial throttle.



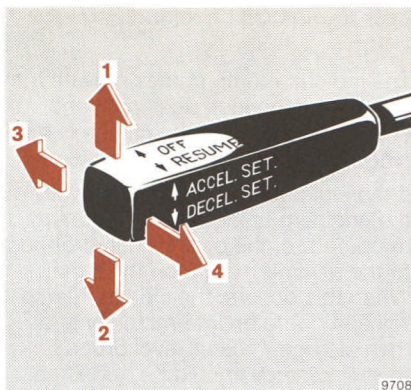

## Cruise Control

Any given speed above approximately 40 km/h (25 mph) can be maintained with the cruise control by operating the lever.

- 1 Accelerate and set:  
Lift lever briefly to set speed.  
Hold lever up to accelerate.
- 2 Decelerate and set:  
Depress lever briefly to set speed.  
Hold lever down to decelerate.

Normally the vehicle is accelerated to the desired speed with the accelerator. Speed is set by briefly pushing the lever to position 1 or 2. The accelerator can be released.

The speed can be increased (e. g. for passing) by using the accelerator. As soon as the accelerator is released, the previously set speed will be resumed automatically.

If a set speed is to be increased or decreased slightly, e. g. to adapt to the traffic flow, hold lever in position 1 or 2 until the desired speed is reached. When the lever is released, the newly set speed remains.

### 3 Cancelling

To cancel the cruise control, briefly push lever to position 3.

When you step on the brake pedal or the vehicle speed falls below approx. 40 km/h (25 mph), for example when driving upgrade, the cruise control will be cancelled.

### 4 Resume

If the lever is briefly pulled to position 4 when driving at a speed exceeding approximately 40 km/h (25 mph), the vehicle resumes the speed which was set prior to the cancellation of the cruise control. The last memorized speed is cancelled when the key is turned to steering lock position 1 or 0.

## Note:

If the engine does not brake the vehicle sufficiently while driving on a downgrade, the speed you set on the cruise control may be exceeded. As soon as the grade eases, the cruise controlled speed will again be maintained as long as the brakes were not applied.

If the set speed was sufficiently exceeded such that the brakes had to be applied, the cruise control can be resumed by pulling the lever to position 4.

## Warning!

**Only use the cruise control if the traffic and weather conditions make it advisable to travel at a steady speed.**

**Position "Resume" should be engaged only if the driver is fully aware of the previously set speed and wishes to resume this particular preset speed.**

**When driving with the cruise control, the transmission selector lever must not be shifted to position "N" as otherwise the engine will over-rev.**

### Engine Oil Consumption

Engine oil consumption can only be determined after a certain mileage has been covered. During the break-in period, higher oil consumption may be noticed and is normal.

### Economical Driving Indicator (ECONOMY)

The indicator shows the fuel consumption tendency during various driving modes.

High fuel consumption is indicated if the pointer moves into the red area; economical driving is indicated when it is in the black area. The indications should only be compared within the same gear.

Do not compare fuel consumption readings between different gears. The following rule applies: If you drive at equal speeds, the fuel consumption is lower in the higher gear, although in this gear the pointer is more frequently in the red area.

### Charge Indicator Lamp

Should the charge indicator lamp fail to come on prior to starting when the key is in steering lock position 2 or should it fail to go out after starting or during operation, this indicates a fault which must be repaired at an authorized MERCEDES-BENZ dealer as soon as possible.

### Oil Pressure Gauge

The oil pressure at idle speed may drop to 0.3 bar (4.4 psi) if the engine is at operating temperature. This will not jeopardize its operational reliability.

Pressure must, however, rise immediately upon acceleration.

### Low Engine Oil Level Indicator Lamp

The indicator lamp comes on with the key in steering lock position 2 and should go out when the engine is running.

If the indicator lamp comes on with the engine running and at operating temperature, the oil level has dropped to the minimum mark on the dipstick. When this occurs, the indicator lamp will first come on intermittently and then stay on if the oil level drops further. Engine oil should be added at the next opportunity (we recommend that you add 1 liter [1.1 US qt]).

In addition to the indicator lamp, the engine oil level should be periodically checked with the dipstick, for example after a fuel stop, or before a long trip (see page 71).

### **Exterior Light Failure Indicator Lamp**

The light failure indicator comes on with the key in steering lock position 2 and will go out when the engine starts.

If it comes on with the engine running, it indicates a light failure.

If an exterior light fails, the indicator will come on only when that light is switched on.

If a brake or turn signal light fails, the light failure indicator will come on when applying the brake or actuating the turn signal and stay on until the engine is turned off.

### **Fuel Reserve Warning Lamp**

The fuel reserve warning lamp will come on when the key is turned to steering lock position 2, and will go out after the engine is running.

If the warning lamp stays on after the engine starts, or comes on while driving, it indicates that the fuel level is down to the reserve quantity (12.5 l [3.3 US gal]).

### **Coolant Temperature Gauge**

If the antifreeze mixture is effective to  $-30^{\circ}\text{C}$  ( $-22^{\circ}\text{F}$ ), the boiling point of the coolant in the pressurized cooling system of your vehicle is approx.  $125^{\circ}\text{C}$  ( $257^{\circ}\text{F}$ ) (see also "Fuels, Coolants, Lubricants, etc.").

During severe operating conditions and stop-and-go city traffic, the coolant temperature may rise close to the red marking.

### **Low Engine Coolant Level Indicator Lamp**

The indicator lamp comes on with the key in steering lock position 2, and should go out when the engine is running.

If it comes on with the engine running, the coolant has dropped below the required level. You should then have the engine cooling system checked for signs of leakage and have it refilled as soon as possible (see page 70).

### **Low Windshield and Headlamp Washer Fluid Level Indicator Lamp**

The indicator lamp comes on with the key in steering lock position 2 and should go out when the engine is running.

If it comes on with the engine running, the level of the reservoir has dropped to about  $\frac{1}{4}$  of the total volume and should be filled with washer fluid to which about 3 capfuls of MB auto-shampoo have been added.



### Outside Temperature Indicator

The temperature sensor is attached to the front bumper behind the license plate base plate. Due to its location, the sensor can be affected by road or engine heat during idling or slow driving. This means that the accuracy of the displayed temperature can only be verified by comparison to a thermometer located next to the sensor, not by comparison to external displays (i.e., bank signs, etc.).

### Brake Pad Wear Indicator Lamp

The brake pad wear indicator lamp in the instrument cluster comes on when the key is turned to steering lock position 2 and it should go out when the engine is running. If the indicator lamp lights up during braking, this shows that the front wheel brake pads are worn.

Have the brake system checked at an authorized MERCEDES-BENZ dealer as soon as possible.

### Brake Warning Lamp

The brake warning lamp will come on if insufficient brake fluid is in the reservoir (key in steering lock position 2 and parking brake released).

When the minimum mark on the reservoir is reached, have the brake system checked (brake lining thickness, leaks).

To test the brake warning lamp, depress the parking brake pedal. Turn key in steering lock to position 2 and the brake warning lamp should come on; release parking brake and the lamp should go out.



## **ABS-Brake System (Antilock Brake System)**

The ABS prevents the wheels from locking up above a speed of approx. 3 km/h (2 mph) independent of road surface conditions. It is necessary, however, that a speed of approx. 8 km/h (5 mph) has been exceeded at least once after start-up.

At the instant one of the wheels is about to lock up, you will feel a slight pulsation in the brake pedal and the vehicle, indicating that the ABS is in the regulating mode.

On slippery road surfaces, the ABS will already respond with a slight brake pedal pressure. The pulsating brake pedal can be an indication of hazardous road conditions, and remind you to take extra care driving.

The ABS indicator lamp in the instrument cluster comes on with the key in steering lock position 2 and should go out with the engine running.

If the charging voltage falls below 10 volts, the indicator lamp comes on and the ABS is switched off. When the voltage is above this value again, the indicator lamp should go out and the ABS will be operational.

If the indicator lamp does not go out or comes on while driving, it indicates that the ABS has detected a malfunction and has switched off. In this case, the brake system functions in the usual manner, but without antilock assistance. We recommend that you visit an authorized MERCEDES-BENZ dealer as soon as possible to have the system checked.

## **Warning!**

**Even the ABS cannot prevent the natural laws of physics from acting on the vehicle. The ABS cannot prevent accidents, including those resulting from excessive speed in turns, following another vehicle too closely, or aquaplaning. Only a safe, attentive, and skillful driver can prevent accidents. The capabilities of an ABS equipped car must never be exploited in a reckless or dangerous manner which could jeopardize the user's safety or the safety of others.**





## Emission Control

Certain systems of the engine serve to keep the toxic components of the exhaust gases within permissible limits required by law.

These systems, of course, will function properly only when maintained strictly according to factory specifications. Any adjustments on the engine should, therefore, be carried out only by qualified MERCEDES-BENZ technicians. The adjustments of the engine should not be altered in any way. Moreover, the specified service and maintenance jobs must be carried out regularly according to MERCEDES-BENZ servicing requirements. For details refer to the Maintenance Booklet.

## Warning!

**Inhalation of exhaust gas is hazardous to your health. All exhaust gas contains carbon monoxide, and inhaling it can cause unconsciousness and lead to death.**

**Do not run the engine in confined areas (such as a garage) which are not properly ventilated. If you think that exhaust gas fumes are entering the vehicle while driving, have the cause determined and corrected immediately. If you must drive under these conditions, drive only with at least one window fully open.**

## Traveling Abroad

Abroad, there is a widely-spread MERCEDES-BENZ service network at your disposal. If you travel into areas which are not listed in the index of your dealer directory, you should request pertinent information from your dealer.

## Winter Driving

Have your car winterized at an authorized MERCEDES-BENZ dealer before the onset of winter.

- Engine oil change: If “year-round” multigrade engine oil is not used, be sure to use an SAE grade based on ambient temperature. For recommended engine oil viscosities refer to “Fuels, Coolants, Lubricants, etc.” and last page.
- Anticorrosion/antifreeze in the coolant: Check anticorrosion/antifreeze protection periodically. For capacity refer to “Fuels, Coolants, Lubricants, etc.”.

- Additive in the windshield and headlamp washing system: Add windshield washer solvent to the water.
- Test battery: Battery capacity drops with decreasing ambient temperature. A well charged battery ensures that the engine can always be started, even at low ambient temperatures.
- Tires: We recommend M+S radial tires on all four wheels for the winter season. Observe permissible maximum speed for M+S radial tires and the legal speed limit.

## Tire Chains

Use only tire chains that are tested and recommended by us. Any authorized MERCEDES-BENZ dealer will be glad to advise you on this subject.

Chains should only be used on the rear wheels. Adhere to the manufacturer’s mounting instructions.

After driving a short distance retighten the mounted chains.

Tire chains should only be driven on snow at speeds not to exceed 50 km/h (30 mph). Remove chains as soon as possible when driving on roads without snow.

For tips on driving on slippery winter roads refer to page 17.







## Practical Hints

Hood – 420 SEL, 560 SEL	68
Hood – 560 SEC	69
Checking Coolant Level	70
Adding Coolant	70
Engine Oil Level Check	71
Fluid Level –	
Automatic Transmission	72
First Aid Kit	73
Stowing Things in the Vehicle	73
Spare Wheel, Jack, Vehicle	
Tool Kit	73
Wheels, Tires	74
Changing Wheels	75
Tire Inflation Pressure	76
Battery	77
Headlamp Adjustment	78
Replacing Bulbs	78
Fuses	82
Spark Plugs	82
Emergency Operation	
of Sliding Roof	83
Unlocking of Fuel Filler Flap	83
Windshield Wipers	83
Tow-starting and Towing	
the Vehicle	84
Jump Starting	85
Cleaning and Care of the Vehicle	86
Ash trays	89
Luggage or Ski Racks	89
Head Restraints	90
Rear Seat Cushion	91
Spare Parts Service	91

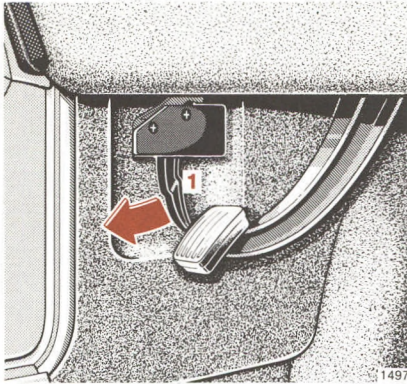

### Hood – 420 SEL, 560 SEL

To open:

To unlock the hood, pull release lever (1) under the driver's side of the instrument panel. At the same time handle (2) will pop out of the radiator grill (it may be necessary to lift the hood up slightly).

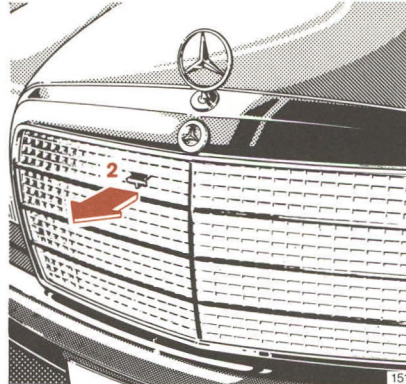

Pull handle (2) completely out of radiator grill and open hood (do not pull up on handle).

### Caution!

To avoid damage to the windshield wipers or hood, open the hood only with wipers in the parked position.

To close:

Close hood by depressing it firmly.

### Warning!

To help prevent personal injury, stay clear of moving parts when the hood is open and the engine is running. Be sure the hood is properly closed before driving.

The engine is equipped with a transistorized ignition system. Because of the high voltage it is dangerous to touch any components (ignition coil, distributor, spark plug sockets, ignition cables, diagnostic socket) of the ignition system

- if the ignition is "on" and the engine revved manually
- while starting the engine
- with the engine running.



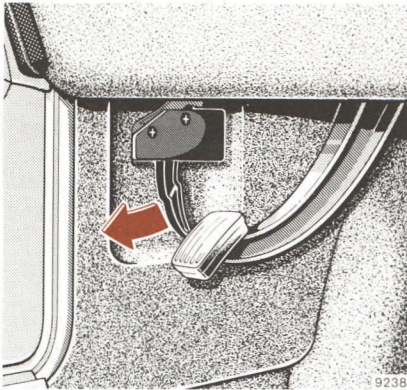

### Hood – 560 SEC

To open:

To unlock the hood, pull release lever under the driver's side of the instrument panel. The hood opens up to the safety catch stop.

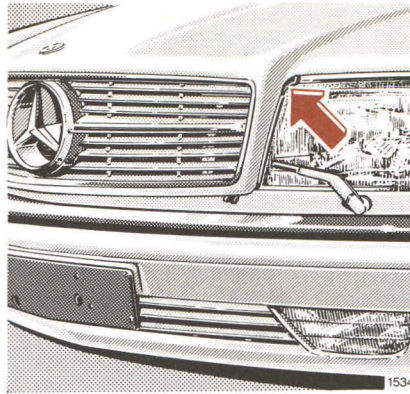

Push in safety catches on LH and RH sides of the radiator grille simultaneously and lift up hood.

### Caution!

To avoid damage to the windshield wipers or hood, open the hood only with wipers in the parked position.

To close:

Close hood by depressing it firmly.

### Warning!

To help prevent personal injury, stay clear of moving parts when the hood is open and the engine is running. Be sure the hood is properly closed before driving.

The engine is equipped with a transistorized ignition system. Because of the high voltage it is dangerous to touch any components (ignition coil, distributor, spark plug sockets, ignition cables, diagnostic socket) of the ignition system

- if the ignition is "on" and the engine revved manually
- while starting the engine
- with the engine running.

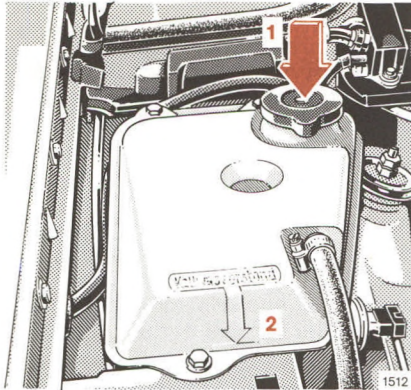

- 1 Coolant reservoir cap
- 2 Marking for coolant level

### Checking Coolant Level

The coolant level can be checked visually at the transparent coolant reservoir.

To check the coolant level, the vehicle must be parked on level ground.

The coolant level must reach:

The marking (2, arrow) on the reservoir when the engine is cold.

Approx. 2 cm (0.8 in) higher when the engine is at operating temperature.

### Adding Coolant

If coolant has to be added, a 50/50 mixture of water and MB anticorrosion/antifreeze should be used.

### Warning!

- **Do not open the engine hood if you see or hear steam or coolant escaping from the engine compartment. With the engine idling and the climate control system switched off, wait until no steam or coolant can be seen before opening the hood.**
- **Do not remove pressure cap on coolant reservoir if engine temperature is above 90° C (194° F). Allow engine to cool down before removing cap. The coolant reservoir contains hot water and is under pressure.**
- **Using a rag, turn cap to first notch to relieve excess pressure. If opened immediately, hot scalding fluid and steam will be blown out under pressure.**

The drain plugs are located on the right and left side of the engine and on the radiator bottom.

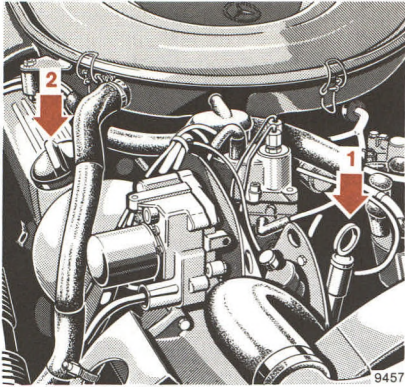

- 1 Oil dipstick
- 2 Oil filler cap

### Engine Oil Level Check

The best time to check the engine oil level is when the oil is warm, such as during a fuel stop. With the vehicle on level ground, stop the engine and wait a few minutes for the oil to drain back to the oil pan.

Wipe the dipstick clean before checking.



Add oil, if needed, only to the upper mark (max.). Do not overfill the engine.

For viscosity and capacity, see "Fuels, Coolants, Lubricants, etc." and last page.

For low engine oil level indicator lamp, see page 60.



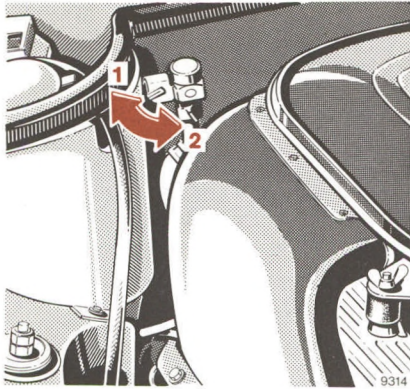

### Fluid Level – Automatic Transmission

Check the fluid level in the automatic transmission regularly and prior to an extended trip.

Check transmission fluid level with the engine idling, parking brake engaged and selector lever in position “P”. The vehicle must be parked on level ground. Prior to the check, allow engine to idle for approx. 1 to 2 minutes.

Measure fluid level with the dipstick completely inserted and the locking lever released (1).

Extreme cleanliness must be observed! To wipe the dipstick, use a clean, lintfree cloth. To fill the transmission with fluid, pour it through a fine-mesh filter into the dipstick opening. Even the slightest impurity may cause operational troubles.

The fluid level in the transmission is dependent upon its temperature. The maximum and minimum oil level marks on the dipstick are applicable references only if the transmission fluid has reached its normal operating temperature of 80° C (176° F).

#### **Important!**

If the transmission fluid cools down to 20–30° C (68–86° F), which is the normal shop temperature range, then the maximum fluid level will be approximately 10 mm (0.4 in) below the minimum mark on the dipstick. We stress this point because a fluid change is normally performed when the transmission fluid has cooled down to shop temperature.

The fluid level must not exceed the dipstick maximum mark with the fluid at operating temperature. Drain or siphon off excess fluid, if required.

Then push dipstick all the way in and swing locking lever downwards (2).



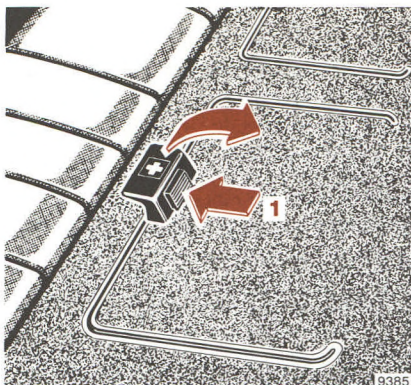

### First Aid Kit

The first aid kit is stored in the shelf below the rear window. To open the lid, push button (1).

### Stowing Things in the Vehicle

#### Warning!

To help avoid personal injury during a collision or sudden maneuver, exercise care when stowing things. Put luggage or cargo in the trunk if possible. Do not pile luggage or cargo higher than the seat backs. Do not place anything on the shelf below the rear window.

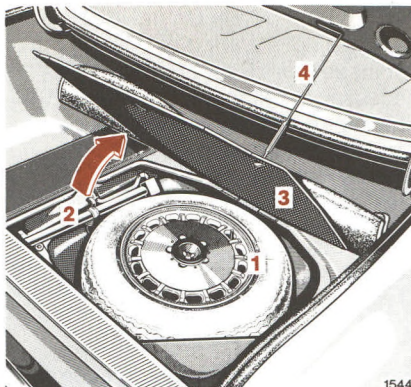

### Spare Wheel, Jack, Vehicle Tool Kit

The spare wheel (1), jack (2) and vehicle tool kit are stored in a compartment below the trunk floor (3).

Prior to lifting up the cover, fold back mats and engage strap (4) in trunk lid.

#### Warning!

The jack is designed exclusively for jacking up the vehicle at the jack tubes built into either side of the vehicle. Use the jack only to lift the vehicle during a tire change. Never get beneath the vehicle while it is supported only by the jack. Jack stands must be used when working under the vehicle. Always set parking brake before raising vehicle with the jack. For details, refer to "Changing Wheels".

## Wheels, Tires

Replace wheels or tires with the same designation, manufacturer and type as shown on the original part.

### Warning!

**Do not mix different tire construction types (i. e. radial, bias, and bias-belted) on your car because handling may be adversely affected and may result in loss of control.**

See any authorized MERCEDES-BENZ dealer for information on tested and recommended wheels and tires for summer and winter operation. They can also offer more advice concerning tire service and purchase.

Front tires should be replaced in sets. If possible, the spare tire should be used on the rear wheels. We recommend that you break in new tires for approx. 100 km (60 miles) at moderate speed.

It is imperative that the wheel mounting bolts be retightened after approx.

800 km (500 miles). On new vehicles retightening is carried out during the 1st inspection. Retightening is also necessary when new wheels are fitted at a later date, e. g. when the spare wheel is used for the first time or when a new set of wheels with M+S tires are installed.

Tightening torque: 110 Nm (80 lb-ft).

For tire specifications, refer to "Technical Data".

### Rotating wheels:

The wheels can be rotated according to the degree of tire wear while retaining the same sense of rotation. Rotating, however, should be carried out before the characteristic tire wear pattern (shoulder wear on front wheels and tread center wear on rear wheels) becomes visible at a mileage of 5000–10000 km (3000–6000 miles) as otherwise the driving properties deteriorate.

Underinflated tires due to a slow leak (e.g. due to a nail in the tire) may

cause damage such as tread separation, bulging, etc. Regular tire pressure checks (including the spare tire) at intervals of no more than 14 days are therefore essential. Keep in mind that warm tires have a higher pressure than cold tires. (See tire pressure chart on fuel filler door and the last page.) If a tire constantly loses air, it should be inspected for damage.

Use only genuine MERCEDES-BENZ wheel bolts (identified by Mercedes-Star on bolt shaft).

Thoroughly clean the inner side of the wheels any time you rotate the wheels or wash vehicle underside.

Dented or bent rims cause tire pressure loss and damage to the tire beads. For this reason, check rims for damage at regular intervals.

The rim flanges must be checked for wear before a tire is mounted. Remove burrs, if there are any.



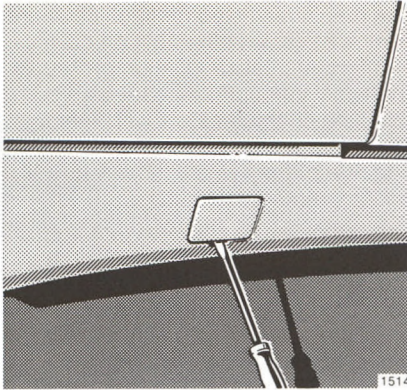

## Changing Wheels

1. Set parking brake.
2. Move selector lever to position "P".
3. Prevent vehicle from rolling away by blocking wheels with wheel chocks: When changing a wheel on a hill, place chocks on the downhill side of each wheel of the other axle; on a level road, place one chock in front of and one behind the wheel that is diagonally opposite to the wheel being changed.

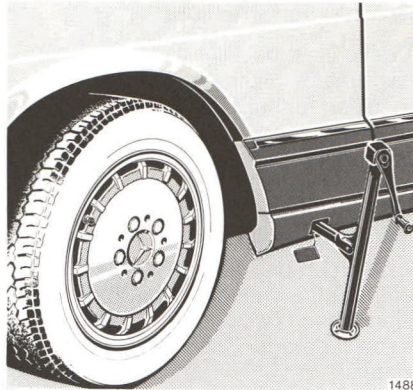

4. Using the combination wrench, loosen but do not yet remove the wheel bolts.
5. Remove cap from the jack support tube. (The tube openings are located directly behind the front wheel housings and in front of the rear wheel housings.)
6. Insert jack arm fully into the tube hole up to the stop. Position the jack so that it will always be vertical as seen from the side, even on inclines. Jack up the vehicle until the wheel is clear off the ground.

## Warning!

The jack is designed exclusively for jacking up the vehicle at the jack tubes built into either side of the vehicle. Use the jack only to lift the vehicle during a tire change. Never get beneath the vehicle while it is supported only by the jack. Jack stands must be used when working under the vehicle.

7. Then unscrew wheel bolts completely. Keep bolt threads protected from dirt and sand.  
While removing last bolt, hold wheel against hub to avoid paint damage on rim.
8. Remove wheel.
9. Screw the alignment bolt (supplied in tool kit) into an upper threaded hole.
10. Adjust the jack height so that the wheel can be slipped on without being lifted.

11. Install spare wheel on wheel hub. Insert wheel bolts and tighten them slightly.  
To avoid paint damage, place wheel flat against hub and hold it there while installing first wheel bolt. Unscrew the alignment stud to install the last wheel bolt.
12. Lower car, remove jack.
13. Engage jack tube cover hooks on top and snap bottom into place.
14. Tighten the five bolts evenly, always skipping one, until all bolts are tight. Observe a tightening torque of 110 Nm (80 lb-ft).
15. Correct tire pressure.

### **Important!**

Retighten wheel mounting bolts after approx. 800 km (500 miles). Observe a tightening torque of 110 Nm (80 lb-ft).

### **Tire Inflation Pressure**

A table (see fuel filler flap or last page) lists the tire inflation pressures specified for summer and winter tires as well as for the varying operating conditions.

#### **Important!**

Tire pressure differs by approx. 0.1 bar (1.5 psi) per 10° C (18° F) of air temperature change. Keep this in mind when checking tire pressure inside a garage – especially in the winter.

Example:

If garage temperature = approx. + 20° C (+ 68° F) and, ambient temperature = approx. 0° C (+ 32° F) then the adjusted air pressure = specified air pressure + 0.2 bar (3 psi).

Tire pressures listed for light loads are minimum values offering high driving comfort. Increased inflation pressures for heavy loads produce favorable handling characteristics with lighter loads and are perfectly permissible. The ride of the vehicle, however, will become somewhat harder.

Tire temperature and pressure increase with the vehicle speed. Tire pressure should therefore only be corrected on cold tires. Correct tire pressure in warm tires only if pressure has dropped below the pressure listed in the table and the respective operating conditions are taken into consideration.



## Battery

Check electrolyte level in each cell approximately every four weeks, and more frequently during the summer and in hot climates.

Refill battery with distilled or tap water. Do not use metal funnels or push through the overfill-protection diaphragms in the filler holes.

The battery is completely filled when the water stops draining through the overfill-protection diaphragm.

To check the battery charge with a hydrometer, push its tip through the overfill-protection diaphragm and take the electrolyte sample.

Coat battery terminal clamps with acidproof grease. Keep battery clean and dry.

The service life of the battery is also dependent on its condition of charge. It must always be sufficiently charged for the battery to last an optimum length of time.

Therefore, we recommend that you have the battery charge checked frequently if you use the vehicle mostly for short distance trips, or if it is not used for long periods of time.

Only charge a battery with a battery charger after it has been disconnected from the vehicle electrical circuit.

## Warning!

**Battery fluid contains sulfuric acid. Do not allow this fluid to come in contact with eyes, skin or clothing.**

**In case it does, immediately flush affected area with water and seek medical help.**

**A battery will also produce hydrogen gas, which is flammable and explosive. Keep flames or sparks away from battery, i.e. improper connection of jumper cables, cigarette smoking, etc..**

**While the engine is running the battery terminal clamps must not be loosened or detached as otherwise the alternator and other electronic units would be damaged.**

**Only tow vehicle with the battery connected.**

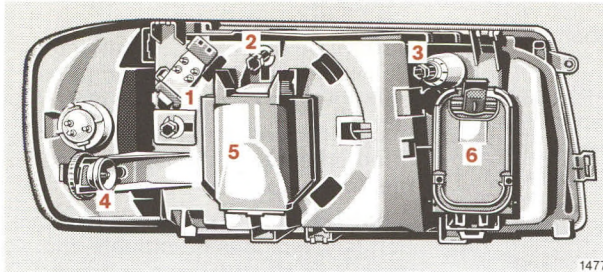

1477

### Headlamp Adjustment

Correct headlamp adjustment is extremely important. Check and readjust headlamps at regular intervals and when a lamp has been replaced.

### Replacing Bulbs

Only handle new bulbs for headlamps and taillamps with tissue paper or similar.

Install only 12 volt bulb with the specified watt rating.

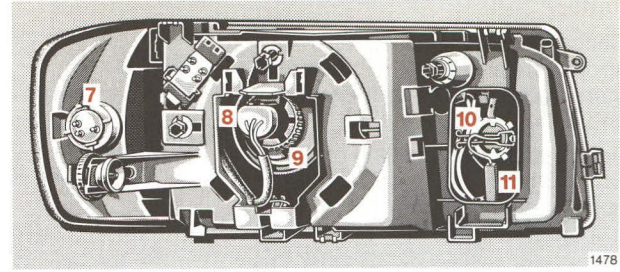

1478

### Headlamp Assembly

- 1 Headlamp horizontal adjustment screw
- 2 Headlamp vertical adjustment screw
- 3 420 SEL, 560 SEL:  
Fog lamp adjustment screw
- 4 Plastic nut for housing of turn signal, parking, side marker and standing lamps
- 5 High and low beam headlamp cover

- 6 420 SEL, 560 SEL:  
Fog lamp cover
- 7 Turn signal, parking, side marker and standing lamp bulb
- 8 Electrical connector for high and low beam headlamp
- 9 Clamping ring for high and low beam headlamp
- 10 420 SEL, 560 SEL:  
Fog lamp bulb
- 11 420 SEL, 560 SEL:  
Electrical connector for fog lamp

Replacing bulbs:

Bulb for turn signal, parking, side marker and standing lamp (21/5 W/ 32/3 cp):

Loosen plastic nut (4) and remove housing towards the front.

Turn bulb socket (7) with bulb counterclockwise and pull out. Push bulb into socket, turn counterclockwise and remove.

Bulb for high and low beam (Halogen type 9004):

Compress cover (5) at the top and remove upwards. Pull off electrical connector (8). Turn clamping ring (9) counterclockwise and pull out bulb together with clamping ring. Remove bulb.

Insert new bulb (flat side facing up), mount clamping ring (9) (with tab facing down) and turn clockwise. Push electrical connector on securely.

420 SEL, 560 SEL:

Fog lamp bulb (Halogen type H3):

Compress the retaining clip of the cover (6) at the top while removing it upwards. Pull off electrical connector (11). Disengage retaining clip and remove bulb (10). When replacing cover (6), make sure it clicks into place.

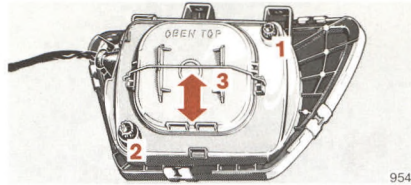

### Fog Lamp 560 SEC

The bulb for the fog lamp is accessible through the wheel well for the purpose of bulb replacement.

- 1 Vertical adjustment screw for the fog lamp
- 2 Horizontal adjustment screw for the fog lamp

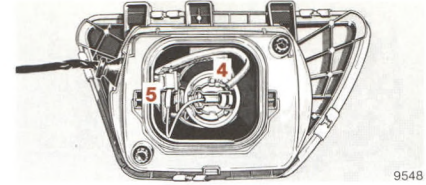

- 4 Bulb for fog lamp (H3):  
Unsnap the bottom of protective cap and remove towards the top. Loosen clip (3) and remove cover. Unplug electric connector (5). Unhook retaining spring and remove bulb.



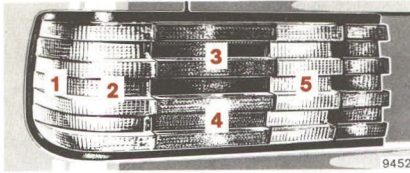

9452

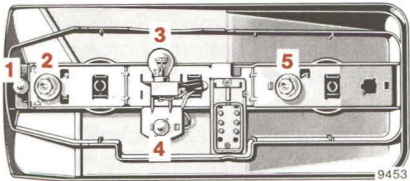

9453

### Taillamp Assemblies

- 1 Side marker lamp (10 W/6 cp)
- 2 Turn signal lamp (21 W/32 cp)
- 3 Stop lamp (21 W/32 cp)
- 4 Tail, parking and standing lamp (10 W/6 cp)
- 5 Backup lamp (21 W/32 cp)

Turn both locks in the trunk to the left as far as the stop and detach lamp bracket. To replace the bulbs, depress, turn to the left and remove.

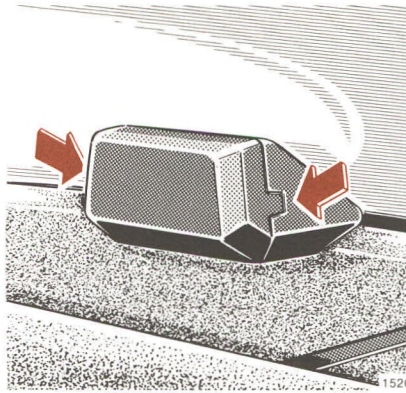

1520

### High Mounted Stop Lamp

(21 W/32 cp)

To replace the bulb, pull tabs on both sides (arrows) – using a screwdriver – to release cover.

Press bulb down, turn counterclockwise and remove.

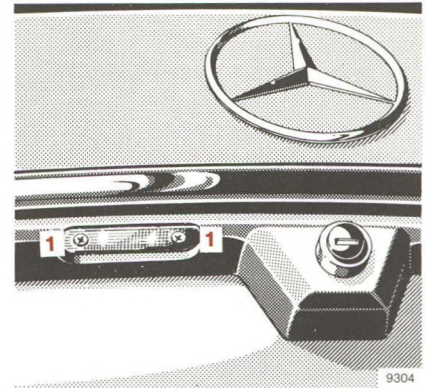

9304

### License Plate Lamps

(5 W lamp)

Loosen both the securing screws (1) and take out lamp.

### Reading Lamps in the Rear Passenger Compartment

(4 W/2 cp)

To change the bulbs, pull out lamps.

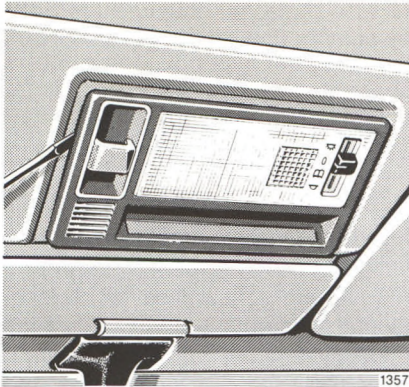

### Interior Lamps

To replace the bulb, push the lamp assembly to the right, lift off the cover on the left side with a screwdriver and pull the lamp assembly out.

Unsnap the reflector to replace the bulb (10 W lamp) for the front and rear dome lighting respectively.

The reading lamp is located inside the front lamp assembly. To replace the reading lamp bulb (Halogen 5 W) push it in, turn it and remove.

To remove the seat belt reminder lamp bulb (1.2 W) located under the front lamp, lift off the cover with the outlined symbol and replace the bulb.

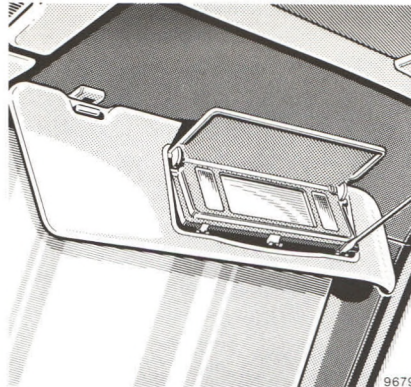

### Sun Visor Lamps (5 W lamp)

To replace a bulb, pry off the cover by inserting a screwdriver in the left and right slots located on the lower edge. To reinstall the mirror assembly, the cover must be closed.

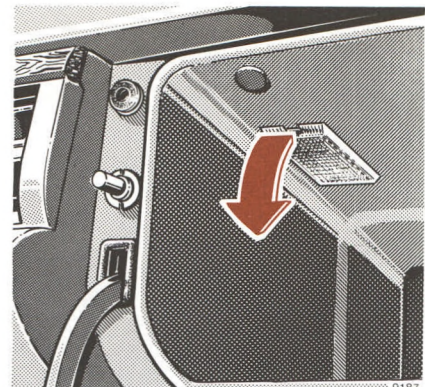

### Glove Compartment Lamp (5 W lamp)

To replace, pull down cover and remove bulb.





### Trunk Lamp (10 W lamp)

Trunk lamp (1) is easily accessible when trunk lid (2) is open.

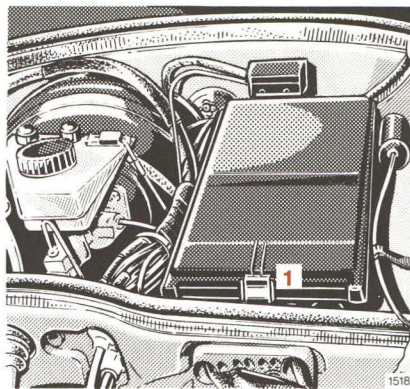

### Fuses

The fuse box is located in the engine compartment.

To exchange a fuse, remove clamp (1) and remove fuse box cover.

All fuse protected equipment is listed by number and letter on a label in the lid of the fuse box. The numbers and letters above the fuses correspond to the ones on the label.

Before replacing a blown fuse, determine the cause of the short circuit.

Spare fuses are furnished inside the fuse box. Observe amperage and color of fuse.

Always use a new fuse for replacement. Never attempt to fix or bridge a blown fuse.

After replacing a fuse, replace fuse box cover and secure with clamp (1).

### Spark Plugs

This vehicle is equipped with spark plugs as required for driving in the USA. Should additional information be necessary, your MERCEDES-BENZ dealer will be happy to offer advice.



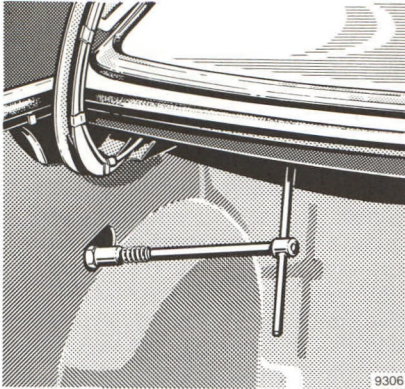

### Emergency Operation of Sliding Roof

The sliding roof can be opened or closed manually should an electrical malfunction occur.

Remove access cover in left side panel of trunk with a screwdriver. Insert socket wrench (from tool kit) through opening in panel and place on the hex-drive of the electric motor. Turn socket wrench (by hand) to open or close roof as desired.

To slide the roof closed: turn clockwise.

To lower the roof at the rear: turn counterclockwise.

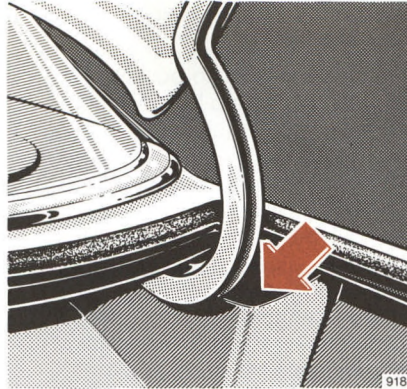

### Unlocking of Fuel Filler Flap

If the central locking system does not release the fuel filler flap automatically, pull back the knob on the vacuum element on the right side of the trunk while opening the filler flap.

### Windshield Wipers

To replace or release frozen windshield wiper blades, the windshield wiper arms can be pulled out of their recess by hand. Sufficient force must be applied to overcome spring resistance. Be careful not to tear rubber blades which are frozen to the glass, as this will reduce the effectiveness of the wipers.

To ensure operation of the windshield wiper even when it is snowing heavily, an overload protection has been installed. It becomes effective if a certain wiping resistance is exceeded as a result of snow accumulation. The windshield wiper arm will then no longer return completely to its initial position, although the windshield wiper motor continues to run a full cycle. If this condition is encountered, the accumulated snow should be manually removed when it is safe.

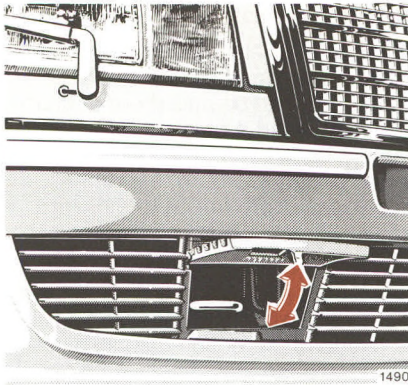

### Tow-starting and Towing the Vehicle

The front towing eye is located on the RH side behind a flap and the rear towing eye on the RH side below the bumper.

Only tow-start vehicle with the battery cables connected and the key in steering lock position 2.

#### Warning!

**When the engine is not running, the brakes and the steering are without power assistance. Under these circumstances, a much greater effort is necessary to steer or stop the vehicle.**

### Emergency Engine Start (Tow-starting)

Shift selector lever to position "N". Turn key to steering lock position 2 and have vehicle towed.

After attaining a towing speed of 30 km/h (18 mph) (with cold transmission) or 50 km/h (30 mph) (with warm transmission), shift selector lever to position "2" to tow-start the engine. Only touch the accelerator when the engine is turning. As soon as the engine has started, quickly return selector lever to "N".

If the engine fails to fire within a few seconds, return the selector lever from "2" to "N" as otherwise the transmission may be damaged.

For another starting attempt, tow car again for a short while with the selector lever in position "N" and then repeat starting procedure.

### Towing a Vehicle

The vehicle may be towed with all wheels on the ground and the selector lever in position "N" for distances up to 120 km (75 miles) and at a speed not to exceed 50 km/h (30 mph).

To positively avoid a possibility of damage to the transmission, however, we recommend to disconnect the drive shaft at the rear axle drive flange on any towing beyond a short tow to a nearby garage.



## Jump Starting

If the battery is discharged the engine can be started with jumper cables and the (12 V) battery of another vehicle. Proceed as follows:

1. Position the vehicle with the charged battery so that the jumper cables will reach, but never let the vehicles touch. Make sure the jumper cables do not have loose or missing insulation.
2. On both vehicles:
  - Turn off engine and all lights and accessories, except hazard flashers or work lights.
  - Apply parking brake and shift selector lever to position "P".
  - Be sure the vent caps are tight and level. Place a damp cloth over the vent caps, making certain it is clear of all moving parts.
3. Clamp one end of the first jumper cable to the positive (+) terminal on the discharged battery and the other end to the positive (+) terminal on the charged battery. Make sure the cable clamps do not touch any other metal parts.
4. Clamp one end of the second jumper cable to the grounded negative (-) terminal of the charged battery and the final connection to a grounded heavy metal bracket in the engine compartment or on the engine of the disabled vehicle. Make sure the cables are not on or near pulleys, fans, or other parts that will move when the engine is started.
5. Start engine of the vehicle with the charged battery and run at high idle. Then start engine of the disabled vehicle in the usual manner.
6. After the engine has started, remove jumper cables by reversing the above installation sequence exactly, starting with the jumper cable connected to a heavy metal bracket in the disabled vehicle's engine compartment. When removing each clamp, make sure that it does not touch any other metal while the other end is still attached.

## Important!

A discharged battery can freeze at approx.  $-10^{\circ}\text{C}$  ( $+14^{\circ}\text{F}$ ). In all cases it must be thawed out before jumper cables are used.

Jumper cables specifications:

- Minimum cable cross-section of  $25\text{ mm}^2$  or approx. 2 AWG
- Maximum length of 3500 mm (11.5 ft).

## Warning!

**Never lean over batteries while jump starting, you might get burned.**

**Battery fluid contains sulfuric acid. Do not allow this fluid to come in contact with eyes, skin, or clothing. In case it does, immediately flush affected area with water, and seek medical help.**

**A battery will also produce hydrogen gas, which is flammable and explosive. Keep flames or sparks away from battery, i.e. improper connection of jumper cables, cigarette smoking, etc..**



## Cleaning and Care of the Vehicle

In operation, your vehicle is subjected to varying external influences which, if gone unchecked, can attack the paintwork as well as the underbody and cause lasting damage.

Such damage is caused not only by extreme and varying climatic conditions, but also by air pollution, road salt, tar, gravel and stone chipping. Grease and oil, fuel, coolant, brake fluid, bird droppings, tree resins, etc. should be removed immediately to avoid paint damage. Frequent washing, however, reduces and/or eliminates the aggressiveness and potency of the above adverse influences.

More frequent washings are necessary to deal with unfavorable conditions; for example, near the ocean, in industrial areas (smoke, exhaust emissions), or during winter operation.

You should check your vehicle from time to time for stone chipping or other damage. Any damage should be repaired as soon as possible to prevent the start of corrosion.

In doing so, do not neglect the underside of the car. A prerequisite for a thorough check is a washing of the underbody followed by a thorough inspection. Damaged areas need to be re-undercoated.

Your vehicle has been treated at the factory with a wax-base rustproofing in the body cavities which will last for the lifetime of the vehicle. Post-production treatment is neither necessary nor recommended by MERCEDES-BENZ because of the possibility of incompatibility between materials used in the production process and others applied later.

After every engine cleaning you should have the engine compartment re-rustproofed with MB anticorrosion wax. Before rustproofing, all control linkage bushings have to be lubricated with hydraulic oil (check with your local MERCEDES-BENZ dealership for recommended brands).

We have selected car-care products and compiled recommendations which are specially matched to our vehicles and which always reflect the latest technology. You can obtain MB car-care products at every MERCEDES-BENZ dealer.

Scratches, corrosive deposits, corrosion or damage due to negligent or incorrect care cannot always be removed with the car-care products recommended here. In such cases it is best to seek aid at your authorized MERCEDES-BENZ dealer.

The following topics deal with the cleaning and care of your vehicle and give important "how-to" information as well as references to recommended MB car-care products.

## **Car Washing**

Before washing your vehicle, remove insect residues. MB insect remover is recommended. Do not use hot water or wash your car in direct sunlight. Use only a mild car wash detergent, such as MB auto shampoo.

Thoroughly spray the car with a diffused jet of water. Direct only a very weak spray towards the ventilation intake. Use plenty of water and rinse the sponge and chamois frequently.

Rinse with clear water and thoroughly wipe dry with a chamois. Do not allow cleaning agents to dry on the finish.

If the vehicle has been run through an automatic car wash – in particular one of the older installations – rewipe the recessed sections in the taillamps (for improved prevention of soiling) if necessary. No solvents (fuels, thinners etc.) must be used.

In the winter, thoroughly remove all traces of road salt as soon as possible.

When washing the underbody, do not forget to clean the inner sides of the wheels.

## **Tar Stains**

Quickly remove tar stains before they dry and become more difficult to remove. MB tar remover is recommended.

## **Window Cleaning, Wiper Blades**

Use a window cleaning solution on very dirty or oil-stained windows. Clean the wiper blade rubber with a clean cloth and detergent solution. Replace blades at least once or twice a year.

To assist with the removal of accumulated road film on the windshield and improve wiping ability, a cap of MB auto shampoo can be added to the 5 liter container of washer solvent.

## **Headlamp Cleaning System**

The condition of the wiper blades is important for satisfactory cleaning of the headlamp lenses. We therefore recommend that the blades are inspected regularly.

Replace damaged wiper blades.

## **Plastic Parts, Headliner and Rubber Parts**

Do not use oil or wax on these parts.

## **Seat Belts**

The webbing must not be treated with chemical cleaning agents. Use only clear, lukewarm water and soap. Do not dry the webbing at temperatures above 80°C (176°F) or in direct sunlight. Never bleach or re-dye the webbing as this may severely weaken the belts.

## **Steering Wheel, Selector Lever and Instrument Cluster**

Use a gentle dish-washing detergent or mild detergent for delicate fabrics as a washing solution. Wipe with a cloth moistened in lukewarm solution. Do not use scouring agents.

## **Upholstery**

**Leather:** Wipe leather upholstery with a damp cloth and dry thoroughly or clean with MB leather care. Exercise particular care when cleaning perforated leather as its underside should not become wet.

**Velours:** Pressure marks resulting from dampness and heat may appear to be stains. Such marks can be removed by wiping with a moistened brush, ironing with a wet cloth or by treating with a dry shampoo. Do not sit on damp upholstery. Quick drying is achieved by applying hot air – for example, by using a hair dryer. If in doubt, please consult your authorized MERCEDES-BENZ dealer.

**Amaretta:** For cleaning brush and vacuum frequently. Use the dry shampoo if the seats have heavy dirt accumulation.

Using aftermarket seat covers or wearing clothing that have the tendency to give off coloring (e. g. when wet, etc.) may cause the upholstery (velour for example) to become permanently discolored. By lining the seats with a proper intermediate cover, contact-discoloration will be prevented.

## **Paintwork, Painted Body Components**

MB-Gloss Preserver should be applied when water drops on the paint surface do not “bead up”; normally in 3–5 months depending on climate and washing detergent used.

MB-Polish should be applied if paint surface shows signs of dirt embedding (i. e. loss of gloss).

MB-Fine Polishing Paste must be used when the paint surface shows signs of excessive fading/chalking due to lack of care, etc..

Do not apply any of these products or wax if your car is parked in the sun or if the hood is still hot. Use the appropriate MB-Touch-Up Stick for quick and provisional repairs of minor paint damage (i. e. chips from stones, car doors, etc.).

## **Light Alloy Wheels**

If possible, clean wheels once a week with MB-alloy wheel cleaner and sealer. Use an ample supply of water.

## **Ornamental Moldings**

For regular cleaning and care of very dirty chrome-plated parts, use a chrome cleaner.



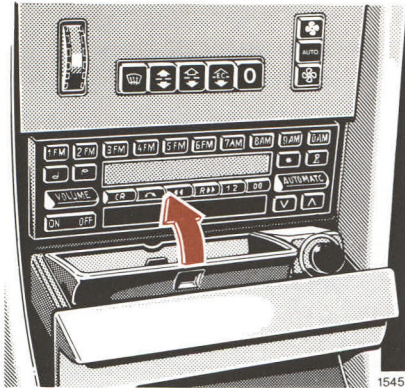

### Ash trays

To remove front ash tray:

Pull ash tray out to the stop, lift up insert and remove.

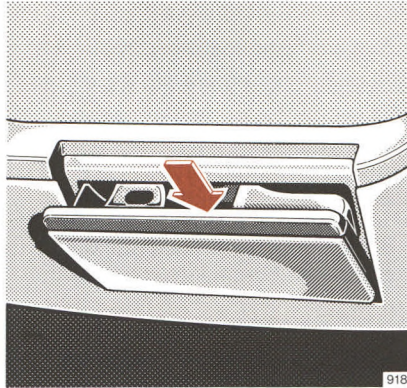

To remove rear ash tray:

Push the ash tray down while opening and remove.

To install ash tray:

Position ash tray squarely and push in.

### Luggage or Ski Racks

We recommend the use of drip rail mounted ski and roof racks. These racks do not require additional supports (suction cups or legs). Such supports may lead to marring of the paint or even denting of the roof if excessive weight is placed on the rack. Your MERCEDES-BENZ dealer can give further advice.

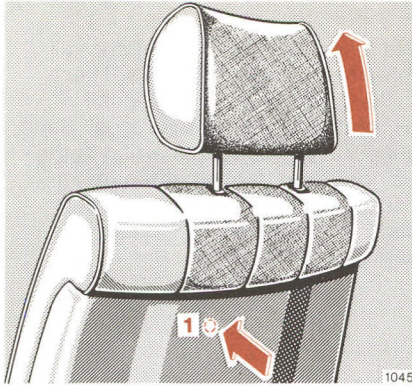

## Head Restraints

Removing front seat head restraints:  
Bring the head restraint to its highest position.

Depress release button (1) under the seatback covering material and pull head restraint up sharply, holding it by the left head restraint post (viewed in driving direction). Then pull out head restraint completely with both hands.

The release button (1) is located below the left head restraint post on both front seats.

Installing front seat head restraints:  
Insert the head restraint and push it down to the stop.

Check if the highest position can be reached by pushing the switch up for approximately 5 seconds.

Adjust head restraint to the desired position.

Removing rear seat head restraints:  
Pull head restraint up until detent is felt. Then pull it out sharply using both hands.

Installing rear seat head restraints:  
Insert the head restraint, push it down and adjust as desired.

### Warning!

**For your protection, drive only with properly positioned head restraints.**

**Do not drive the vehicle without the front seat head restraints. Head restraints are intended to help reduce injuries during an accident.**

For positioning of head restraints refer to pages 29 and 30.

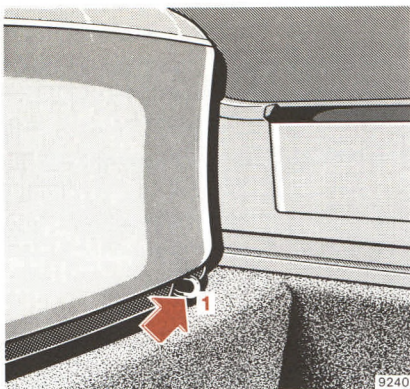

### Rear Seat Cushion

**Removal:** Push in locking buttons 1 (left and right) outwards while slightly lifting the front corner of the seat cushion. Then pull the seat cushion forward.

**Installation:** Push rear of seat cushion under seat back as far as it will go and press down on the front section until it engages.

**Note:**

On vehicles with power rear seats, the rear seat cushion can best be removed and installed by an authorized MERCEDES-BENZ dealer.

### Spare Parts Service

All MERCEDES-BENZ dealers maintain a stock of original spare parts required for maintenance and repair work. In addition, strategically located parts distribution centers provide quick and reliable parts service.

More than 200 000 different spare parts, even for older models, are available.

MERCEDES-BENZ original spare parts are subjected to most severe quality inspections. Each part has been specifically developed, manufactured or selected for and adapted to MERCEDES-BENZ vehicles.

Therefore, MERCEDES-BENZ original spare parts should be installed.





## **Technical Data Fuels Coolants Lubricants etc.**

Identification Plates	94
Vehicle Data Cards	95
Warranty Coverage	95
Technical Data 420 SEL	96
Technical Data 560 SEL, 560 SEC	97
Fuels, Coolants, Lubricants etc.	98
Capacities	98
Engine Oils	100
Brake Fluid	100
Premium Unleaded Gasoline	100
Fuel Requirements	100
Coolants	101
Consumer Information	102

## Identification Plates

When ordering spare parts, please specify chassis and engine numbers.

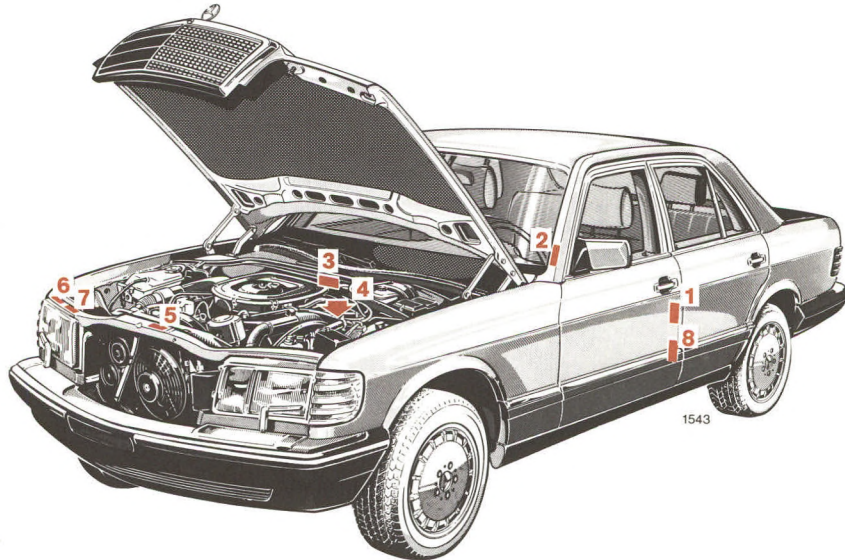

- 1 Certification Tag  
(left door pillar)
- 2 Identification Tag  
(left window post)
- 3 Vehicle Identification No.
- 4 Engine No.
- 5 Body No. and Paintwork No.
- 6 Emission Control Tag  
(560 SEC left side)
- 7 Information Tag  
California version  
Vacuum line routing for  
emission control system
- 8 Emission Control Tag  
Catalyst Information



## Vehicle Data Cards

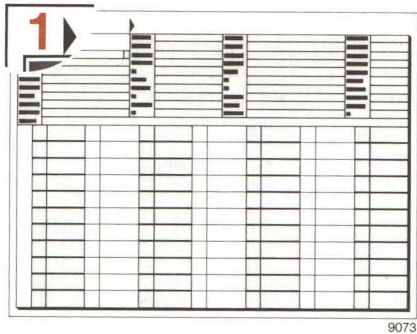

The vehicle data cards bear all the important data relating to your vehicle.

Data card No. 1 bears the key number and should never be left in the vehicle. Submit this card to your authorized MERCEDES-BENZ dealer to request a replacement key in case of loss.

Data card No. 2 has no key number information and should be kept in the Maintenance Booklet where indicated.

## Warranty Coverage

Your car is covered under the terms of the “warranties” printed in the Owner’s Service and Warranty Policy Booklet and your dealer will exchange or repair any defective parts in accordance with the terms of the following warranties:

1. New vehicle limited warranty
2. Emission systems warranty
3. Emission performance warranty
4. California emission control systems warranty (State of California only, unless purchased optionally for diesel models).

Loss of Owner’s Service and Warranty Policy

Should you lose your Owner’s Service and Warranty Policy Booklet, have your local MB dealer arrange for a replacement. It will be mailed to you.

## Technical Data 420 SEL

Model	420 SEL (126 035) <sup>1</sup>
-------	--------------------------------

### Engine

Engine type	116
Mode of operation	4-stroke engine, gasoline injection
No. of cylinders	8
Bore	92.0 mm (3.62 in)
Stroke	78.9 mm (3.11 in)
Total piston displacement	4196 cm <sup>3</sup> (256.1 in <sup>3</sup> )
Compression ratio	9.0
Output acc. to SAE J 1349	150 kW/5200 rpm (201 hp/5200 rpm)
Firing order	1-5-4-8-6-3-7-2
V-belts:	
Water pump – fan – power steering pump 2 V-belts	9.5 × 1100 mm
Alternator	9.5 × 990 mm
Air conditioning	12.5 × 960 mm
Air pump	9.5 × 750 mm

### Rims – Tires

Rims (forged light alloy rims)	7 J x 15 H 2
Wheel offset	25 mm (1.0 in)
Summer tires: Radial-ply tires	205/65 VR 15
Winter tires: Radial-ply tires	205/65 R 15 93 T M+S

### Electrical System

Alternator	14 V/80 A
Starter motor	12 V/1.5 kW
Battery	12 V/66 Ah
Spark plugs	see last page

<b>Weights</b>	See certification tag
----------------	-----------------------

### Main Dimensions

Overall vehicle length	5285 mm (208.1 in)
Overall vehicle width	1820 mm ( 71.1 in)
Overall height	1441 mm ( 56.7 in)
Wheel base	3075 mm (121.1 in)
Track, front	1555 mm ( 61.2 in)
Track, rear	1527 mm ( 60.1 in)

<sup>1</sup> The quoted data apply only to the standard vehicle. See an authorized MERCEDES-BENZ dealer for the corresponding data of all special bodies and special equipment.

## Technical Data 560 SEL, 560 SEC

Model	560 SEL (126 039) <sup>1</sup> 560 SEC (126 045) <sup>1</sup>
-------	------------------------------------------------------------------

### Engine

Engine type	117
Mode of operation	4-stroke engine, gasoline injection
No. of cylinders	8
Bore	96.5 mm (3.8 in)
Stroke	94.8 mm (3.7 in)
Total piston displacement	5547 cm <sup>3</sup> (338.5 in <sup>3</sup> )
Compression ratio	9.0
Output acc. to SAE J 1349	178 kW/4800 rpm (238 hp/4800 rpm)
Firing order	1-5-4-8-6-3-7-2
V-belts:	
Water pump – fan – power steering pump 2 V-belts	9.5 × 1100 mm
Alternator	9.5 × 1005 mm
Air conditioning	12.5 × 960 mm
Air pump	9.5 × 750 mm

### Rims – Tires

Rims (forged light alloy rims)	7 J x 15 H 2
Wheel offset	25 mm (1.0 in)
Summer tires:	
Radial-ply tires	205/65 VR 15
Winter tires:	
Radial-ply tires	205/65 R 15 93 T M+S

### Electrical System

Alternator	14 V/80 A
Starter motor	12 V/1.5 kW
Battery	12 V/92 Ah
Spark plugs	see last page

### Weights

See certification tag

### Main Dimensions 560 SEL

Overall vehicle length	5285 mm (208.1 in)
Overall vehicle width	1820 mm ( 71.7 in)
Overall height	1441 mm ( 56.7 in)
Wheel base	3070 mm (120.9 in)
Track, front	1555 mm ( 61.2 in)
Track, rear	1527 mm ( 60.1 in)

### Main Dimensions 560 SEC

Overall vehicle length	5060 mm (199.2 in)
Overall vehicle width	1828 mm ( 72.0 in)
Overall height	1412 mm ( 55.6 in)
Wheel base	2845 mm (112.0 in)
Track, front	1555 mm ( 61.2 in)
Track, rear	1527 mm ( 60.1 in)

<sup>1</sup> The quoted data apply only to the standard vehicle. See an authorized MERCEDES-BENZ dealer for the corresponding data of all special bodies and special equipment.



## Fuels Coolants Lubricants etc. Capacities

Vehicle components and their respective lubricants must match. Therefore use only brands tested and recommended by us. Inquire at your authorized MERCEDES-BENZ dealer.

	Capacity	Fuels, coolants, lubricants, etc.
Engine with oil filter	8.0 l (8.5 US qt)	<p>Recommended engine oils</p> <p>Ambient temp.   SAE grades</p> <p>°F   °C</p> <p>+86   +30 +68   +20 +50   +10 +32   0 +23   -5 +14   -10 +5   -15 -4   -20</p> <p>5W-20 5W-30 10W-30 20W-40 20W-50 15W-40 15W-50 10W-40 10W-50</p> <p>Year-round use multigrade oil</p> <p>8938</p> <p><sup>1</sup> SAE 40 may be used if ambient temperatures constantly exceed +30° C (+86° F).</p>
Automatic transmission	Initial fill: 8.6 l (9.1 US qt) Fluid change: 7.7 l (8.1 US qt)	Automatic transmission fluid for automatic transmission <sup>2</sup>

<sup>2</sup> For recommendations on recommended brands, see your nearest MERCEDES-BENZ dealer.

	Capacity	Fuels, coolants, lubricants, etc.	
Rear axle	420 SEL	1.3 l (1.4 US qt)	Hypoid gear oil SAE 90, 85 W 90 <sup>1</sup>
	560 SEL, 560 SEC	1.3 l (1.4 US qt)	Hypoid gear oil SAE 90 for limited slip differential <sup>1</sup>
Power steering		1.2 l (1.3 US qt)	Automatic transmission fluid for power steering <sup>1</sup>
Level control	560 SEL, 560 SEC	2.0 l (2.1 US qt)	Hydraulic oil <sup>1</sup>
Front wheel hubs		approx. 60 g (2.1 oz) each	High temperature roller bearing grease
Battery terminals			Bosch special grease
Accelerator control linkage			Hydraulic fluid <sup>1</sup>
Grease nipples			Multipurpose or lubrication grease
Door locks			Powdered graphite
Brake reservoir		approx. 0.5 l (0.5 US qt)	Brake fluid <sup>1</sup>
Windshield washer system and headlamp cleaning system		approx. 5.0 l (5.3 US qt)	Windshield washer solvent
Fuel tank including a reserve of		approx. 90 l (23.8 US gal) approx. 12.5 l (3.3 US gal)	Premium unleaded gasoline: Posted Octane 91 (Average of 96 RON/86 MON)
Cooling system		approx. 13.0 l (13.7 US qt)	Coolant <sup>1</sup>

<sup>1</sup> For recommendations on recommended brands, see your nearest MERCEDES-BENZ dealer.

## Engine Oils

Engine oils are specifically tested for their suitability in our engines. Therefore, use only engine oils recommended by us. Information on recommended brands is available at any authorized MERCEDES-BENZ dealer.

## Brake Fluid

During vehicle operation, the boiling point of the brake fluid is continuously reduced through the absorption of moisture from the atmosphere. Under extremely hard operating conditions, this moisture content can lead to the formation of vapor in the system thus reducing the system's efficiency.

The brake fluid must therefore be replaced annually, preferably in the spring.

It is recommended to use only brake fluid approved by MERCEDES-BENZ. Your MERCEDES-BENZ dealer will provide you with additional information.

## Premium Unleaded Gasoline

### Caution!

To maintain the engine's durability and performance, premium unleaded gasoline must be used. If premium unleaded is not available and low octane fuel is used, follow these precautions:

- have the fuel tank filled only partially with unleaded regular and fill up with premium unleaded as soon as possible,
- avoid full throttle driving and abrupt acceleration,
- do not exceed an engine speed of 2000 rpm, if the vehicle is loaded with a light load such as two persons and no luggage,
- do not exceed  $\frac{3}{4}$  of maximum accelerator pedal position, if the vehicle is fully loaded, towing a trailer or operating in mountainous terrain.

## Fuel Requirements

Use only Premium unleaded meeting ASTM standard D 439:

The octane number (posted at the pump) must be 91 min. It is an average of both, the Research (R) octane number and the Motor (M) octane number:  $(R + M/2)$ . This is also known as ANTI-KNOCK INDEX.

Unleaded gasoline containing oxygenates such as Ethanol, MTBE, IPA, IBA and TBA can be used provided the ratio of either one of these oxygenates to gasoline does not exceed 10%.

The ratio of Methanol to gasoline must not exceed 3% plus additional cosolvents.

Using mixtures of Ethanol and Methanol is not allowed. MTBE may, however, be added up to 15%. Gasohol, which contains 10% Ethanol and 90% unleaded gasoline, can be used.

These blends must also meet all other fuel requirements such as resistance to spark knock, boiling range, vapor pressure, etc..



## Coolants

The engine coolant is a mixture of water and anticorrosion/antifreeze, which provides:

- corrosion protection
- freeze protection
- boiling protection (by increasing the boiling point).

The cooling system was filled at the factory with a coolant providing freeze protection to  $-30^{\circ}\text{C}$  ( $-22^{\circ}\text{F}$ ) and corrosion protection. The red area of the temperature gauge is matched to the heating properties of this coolant solution.

The coolant solution must be used year round to provide the necessary corrosion protection and increase in the boil-over protection. You should have it replaced every 3 years.

To provide the important corrosion protection, the solution must be at least 33% anticorrosion/antifreeze (equals a freeze protection to  $-20^{\circ}\text{C}$  [ $-4^{\circ}\text{F}$ ]). If you use a solution that is more than 55% anticorrosion/antifreeze (freeze protection to  $-45^{\circ}\text{C}$  [ $-49^{\circ}\text{F}$ ]), the engine temperature will

increase due to the lower heat transfer capability of the solution. Therefore, do not use more than this amount of anticorrosion/antifreeze.

If the coolant level is low, water and MB anticorrosion/antifreeze should be used to bring it up to the proper level (have cooling system checked for signs of leakage).

The water in the cooling system must meet minimum requirements, which are usually satisfied by normal drinking water. If you are not sure about the water quality, consult your authorized MERCEDES-BENZ dealer.

### Anticorrosion/antifreeze

Your vehicle contains a number of aluminium parts. The use of aluminium components in motor vehicle engines necessitates that anticorrosion/antifreeze/coolant used in such engines be specifically formulated to protect the aluminium parts. (Failure to use such anticorrosion/antifreeze/coolant will result in a significantly shortened service life.)

Therefore the following product, is strongly recommended for use in your car: MERCEDES-BENZ Anticorrosion/ Antifreeze Agent.

Before the start of the winter season (or once a year in the hot southern regions), you should have the anticorrosion/antifreeze concentration checked. The coolant is also regularly checked each time you bring your vehicle to your authorized MERCEDES-BENZ dealer for maintenance service.

Freeze protection	Anticorrosion/antifreeze
$-30^{\circ}\text{C}$ } $(-22^{\circ}\text{F})$ }	5.75 l (6.1 US qt)
$-45^{\circ}\text{C}$ } $(-49^{\circ}\text{F})$ }	6.75 l (7.1 US qt)

## Consumer Information

This has been prepared as required of all manufacturers of passenger cars under Title 49, Code of U.S. Federal Regulations, Part 575 pursuant to the "National Traffic and Motor Vehicle Safety Act of 1966".

### Uniform Tire Quality Grading

Relevant tire grade information on tire flanks.

All passenger car tires must conform to federal safety requirements in addition to these grades.

### Treadwear

The treadwear grade is a comparative rating based on the wear rate of the tire when tested under controlled conditions on a specified government test course. For example, a tire graded 150 would wear one and a half (1½) times as well on the government course as a tire graded 100. The relative performance of tires depends upon the actual conditions of their use, however, and may depart significantly from the norm due to variations in driving habits, service practices and differences in road characteristics and climate.

### Traction "A", "B", "C"

The traction grades, from highest to lowest, are "A", "B" and "C" and they represent the tire's ability to stop on wet pavement as measured under controlled conditions on specified government test surfaces of asphalt and concrete. A tire marked "C" may have poor traction performance.

### Warning!

**The traction grade assigned to this tire is based on braking (straight-ahead) traction tests and does not include cornering (turning) traction.**

### Temperature "A", "B", "C"

The temperature grades of "A" (the highest), "B" and "C" representing the tire's resistance to the generation of heat and its ability to dissipate heat when tested under controlled conditions on a specified indoor laboratory test wheel. Sustained high temperature can cause the material of the tire to degenerate and reduce tire life, and excessive temperature can lead to sudden tire failure. The grade "C" corresponds to a level of performance which all passenger car tires must meet under the Federal Motor Vehicle Safety Standard No. 109. Grades "B" and "A" represent higher levels of performance on the laboratory test wheel than the minimum required by law.

### Warning!

**The temperature grade for this tire is established for a tire that is properly inflated and not overloaded. Excessive speed, underinflation, or excessive loading, either separately or in combination, can cause heat buildup and possible tire failure.**

## Vehicle Stopping Distance

This figure indicates braking performance that can be met or exceeded by the vehicles to which it applies, under different conditions of loading and with partial failures of the braking system. The information presented represents results obtainable by skilled drivers under controlled road and vehicle conditions, and the information may not be correct under other conditions.

Description of the vehicles to which this table applies: **420 SEL, 560 SEL, 560 SEC**

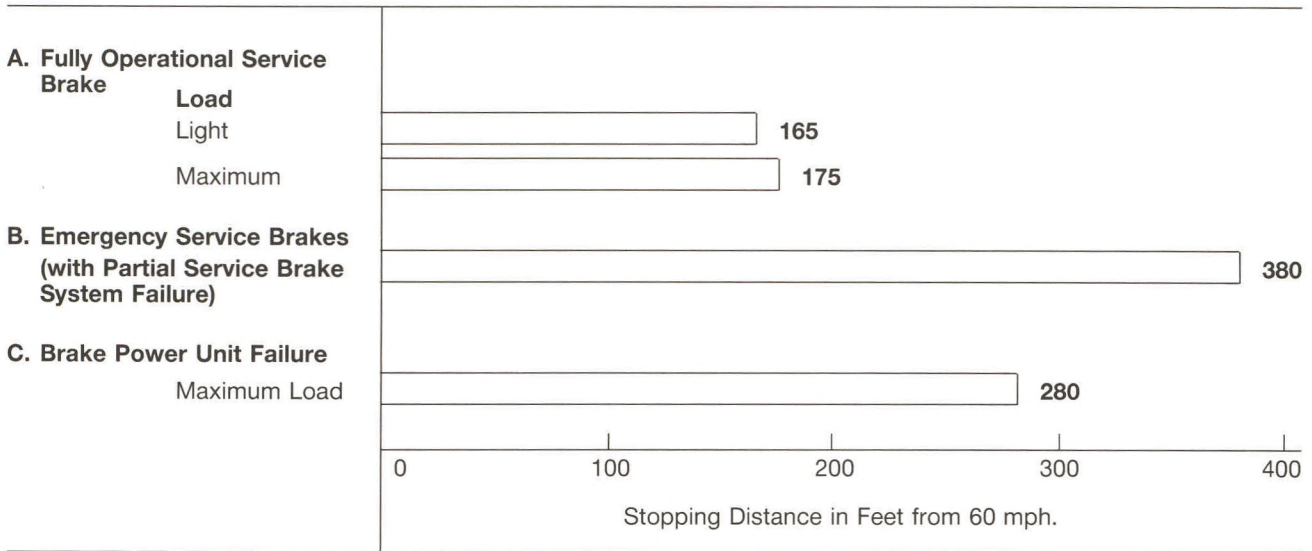





# Index



**Airbag** 38  
Alarm system 28  
Alloy wheels 88  
Antenna 53  
Anticorrosion/antifreeze 101  
Arm rest 31, 33  
Ash trays 89  
Automatic climate control 20

**Battery** 77  
Body no. 94  
Brake fluid 100  
Brake pad wear indicator  
  lamp 62  
Brake, parking 56  
Brakes 16  
Brakes, ABS 63  
Brake warning lamp 62  
Break-in period 8

**Capacities** 98  
Catalytic converter cautions 14  
Central locking system 27  
Certification tag 94  
Charge indicator lamp 60  
Cleaning and care of the vehicle 86  
Combination switch 43  
Consumer information 102  
Coolant level check 70  
Coolants 99, 101  
Coolant temperature  
  gauge 61  
Cruise control 59

**Doors** 26  
Driver checks 112  
Driving hints 16

**Economical driving indicator**  
  (ECONOMY) 60  
Emergency tensioning  
  retractors 35  
Emission control 64  
Emission control tag 94  
Engine no. 94  
Engine oil and filter  
  change 18  
Engine oil consumption 60  
Engine oil level check 71  
Engine oils 100  
Engine starting and turning off 15  
Exterior lamp switch 42  
Exterior light failure  
  indicator lamp 61

**First aid kit** 73  
Fog lamps 78, 79  
Fuel filler flap 83  
Fuel requirements 100  
Fuel reserve warning lamp 61  
Fuels, coolants, lubricants, etc. 98  
Fuses 82

**Gauges** 12, 60, 61  
  Oil pressure 60  
  Coolant temperature 61  
  Fuel 12



**Headlamps** 78, 43  
Headlamp washer 43  
Head restraints 29, 33, 90  
    front 29, 90  
    rear 33, 90  
Heated seats 32  
Hood 68, 69  
  
Identification plates 94  
Indicator lamps 12, 60, 61, 62  
    Brake pad wear 62  
    Brake warning 62  
    Charging system 60  
    Exterior light failure 61  
    Fuel reserve 61  
    Low coolant 61  
    Low engine oil 60  
    Low washer fluid 61  
Instruments and controls 10  
Instrument cluster 12

**Jack** 73  
Jump starting 85  
  
**Keys** 25  
  
**Lamps, exterior** 78, 79, 80  
    Fog lamps 78, 79  
    Headlamps 78  
    High mounted stop lamp 80  
    License plate lamps 80  
    Switch 42  
    Taillamps 80  
**Lamps, interior** 47, 80, 81, 82  
    Glove compartment 81  
    Reading 80, 81  
    Sun visor 81  
    Trunk 82  
Lighter 45  
Literature 109  
Lubricants 98  
Luggage or ski racks 89

**Maintenance** 4, 18  
  
**Oil pressure gauge** 60  
Orthopedic seat 31  
Outside temperature indicator 62  
  
**Paintwork no.** 94  
Parking 17  
Parking brake 56  
Premium unleaded gasoline 99, 100  
  
**Radio** 49  
Rear view mirrors 44  
Rear window defroster 46  
Restraint systems,  
    infants and children 40  
Roadside assistance 4

**Seat belts** 35  
    Reminder lamp and warning  
    buzzer 35  
**Seats** 29, 30, 33, 34, 91  
    front 29, 30  
    rear 33, 34, 91  
**Service literature** 109  
**Shelf below rear window** 48  
**Shifting** 56  
**Sliding roof** 47  
    Emergency operation 83  
**Spare parts** 91  
**Spare wheel** 73  
**Spark plugs** 82  
**Starting and shifting gears** 56  
**Starting and turning off**  
    engine 15  
**Steering column, adjusting** 34  
**Steering lock** 41  
**Stowing things** 73  
**Sun visors** 45  
**Supplemental restraint system**  
    (SRS) 35

**Technical data** 96, 97  
**Tire chains** 65  
**Tire pressure** 76  
**Tires** 16, 74, 102  
**Tool kit** 73  
**Towing** 84  
**Transmission, fluid**  
    level check 72  
**Traveling abroad** 64  
**Turn signals** 43

**Upholstery, cleaning** 88  
  
**Vanity mirrors** 45  
**V-belt** 96, 97  
**Vehicle data cards** 95  
**Vehicle identification no.** 94  
  
**Warranty** 4, 95  
**Wheels** 74  
**Wheels, changing** 75  
**Windows** 48  
**Windshield/headlamp washer**  
    system 43  
**Windshield wipers** 83  
**Winter driving** 17, 65

## Service Literature

Your authorized MERCEDES-BENZ dealer has trained technicians and original MERCEDES-BENZ parts to service your vehicle properly. For expert advice and quality service, see your authorized MERCEDES-BENZ dealer.

Customers who are interested in ordering service literature for their vehicles are advised to contact MERCEDES-BENZ distributors in the U. S. or Canada at the following addresses, respectively

for U.S.A.: Mercedes-Benz of North America Inc.  
One Mercedes Drive  
P. O. Box 350  
Montvale, New Jersey 07645  
Att: Technical Publications  
Tel: (201) 573-0600

for Canada: Mercedes-Benz Canada Inc.  
849 Eglinton Ave., East  
Toronto, Ont., Canada  
M4G 2L5  
Att: Technical Publications  
Tel: 416-425-3550  
Telex: 065-24232

The above companies will be happy to handle any such requests from customers.

We consider this to be the best way to obtain accurate information for your vehicle.

## Warning!

**To help avoid personal injury, be extremely careful when performing, any maintenance work or repairs. Improper or incomplete service may damage the vehicle or its equipment, which may in turn result in personal injury.**

**If you have any question about carrying out some service, turn to the advice of an authorized MERCEDES-BENZ dealer.**







## Check Regularly and Before a Long Trip

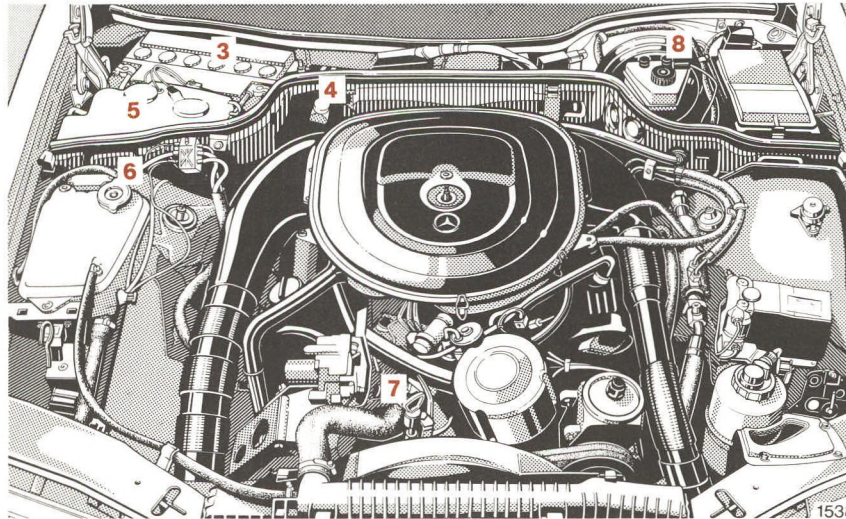
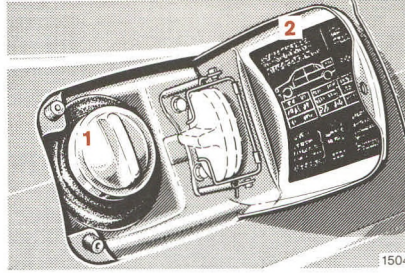
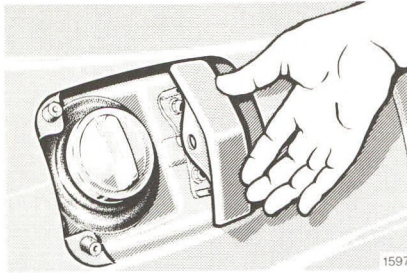

- 1 Fuel Supply:** Turn fuel filler cap to the left and hold on to it until possible pressure in tank has been released.
  - 2 Tire Pressure:** Check at least every two weeks. For details see page 76.
  - 3 Battery:** Add distilled water only, see page 77.
  - 4 Fluid Level in Automatic Transmission:** See page 72.
  - 5 Windshield Washer System, Headlamp Cleaning System:** See page 99.
  - 6 Coolant Level:** See page 70.
  - 7 Engine Oil Level:** See page 71.
  - 8 Brake Fluid:** See pages 99 and 100.
- Vehicle Lighting:** Check function and cleanliness. For replacement of light bulbs, see pages 78, 79 and 80.

## What You Should Know at the Gas Station

- **Fuel:** Use premium unleaded gasoline: Posted Octane 91 (Average of 96 RON/86 MON).

Fuel tank capacity approx. 90 l (23.8 US gal), this includes approx. 12.5 l (3.3 US gal) reserve.

Only fill fuel tank until the filler nozzle unit cuts out – do not overfill.

- **Engine Oil:** Engine oil level check, see page 71.

Quantity differential between upper and lower dipstick marking level: 2.0 l (2.1 US qt).

Year-round multigrade oils 10 W-40, 10 W-50, 15 W-40, 15 W-50.

For further information, refer to page 98.

- **Automatic Transmission:** Automatic transmission fluid for automatic transmission.

For level checks and replenishment, refer to page 72.

- **Tire Pressure:** For driving up to 160 km/h (100 mph)

Cold tires:

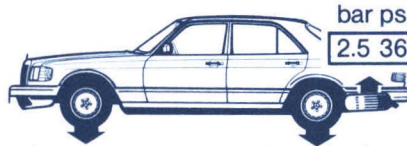

Summer tires	normal load
	maximum load
Winter tires:	

bar	psi
2.0 <sup>1</sup>	29 <sup>1</sup>
2.1 <sup>1</sup>	30 <sup>1</sup>
2.3 <sup>1</sup>	33 <sup>1</sup>

bar	psi
2.1 <sup>1</sup>	30 <sup>1</sup>
2.4 <sup>1</sup>	35 <sup>1</sup>
2.6 <sup>1</sup>	38 <sup>1</sup>

- **Coolant:** For normal replenishment, use water (potable water quality).

For further information (e.g. anticorrosion/antifreeze), refer to page 101.

- **Bulbs:** High and low beams: Halogen type 9004, tail, parking and standing lamps 10 W/6 cp, turn signal, standing, side marker and parking lamps, front 21/5 W/32/3 cp, turn signal lamps, rear 21 W/32 cp, stop lamps 21 W/32 cp, license plate lamps 5 W lamp.

- **Spark Plugs:** 420 SEL: Bosch W 8 DC, Beru 14-8 DU, Champion N 9 YC. 560 SEL, 560 SEC: Bosch W 9 DC, Beru 14-9 DU, Champion N 9 YC.

Warm tires:

Pressure may rise by up to +0.5 bar (+7 psi).

Never release any air from a warm tire to off-set this pressure increase!

<sup>1</sup> For driving above 160 km/h (100 mph) +0.6 bar (+9 psi).



**DAIMLER-BENZ AG**  
Stuttgart-Untertuerkheim  
Zentralkundendienst



Mercedes-Benz  
**service**

126 584 06 97

USA Augsburg A/4 1086



