

Owner's Manual

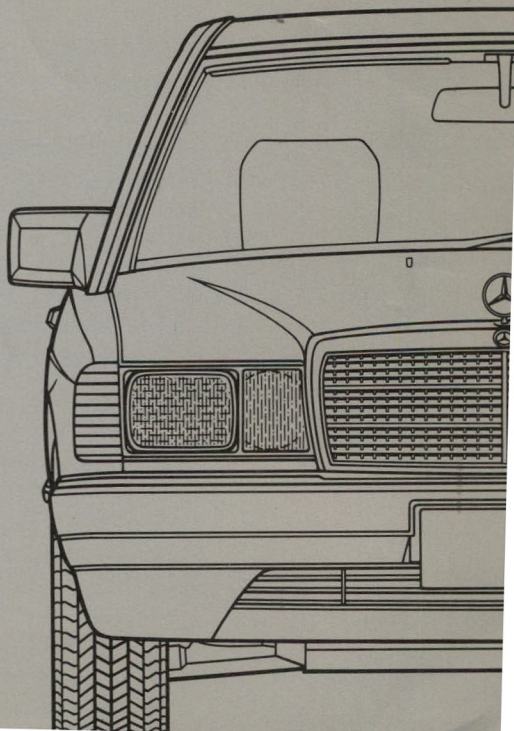

190 E 2.3

1986



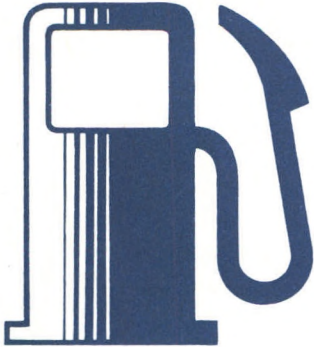

Drive Sensibly – Save Fuel

Fuel consumption, to a great extent, depends on driving habits and operating conditions.

To save fuel you should:

- keep tires at the recommended inflation pressures
- remove unnecessary loads
- remove ski racks or roof-mounted luggage racks when not in use
- allow engine to warm up under low load use
- avoid frequent acceleration and deceleration
- have all maintenance work performed at regular intervals by an authorized MERCEDES-BENZ dealer.

Driving in cold weather, in stop-and-go city traffic, on short trips, and in hilly country also increase fuel consumption.

Owner's Manual



190 E 2.3

Model 201

1986

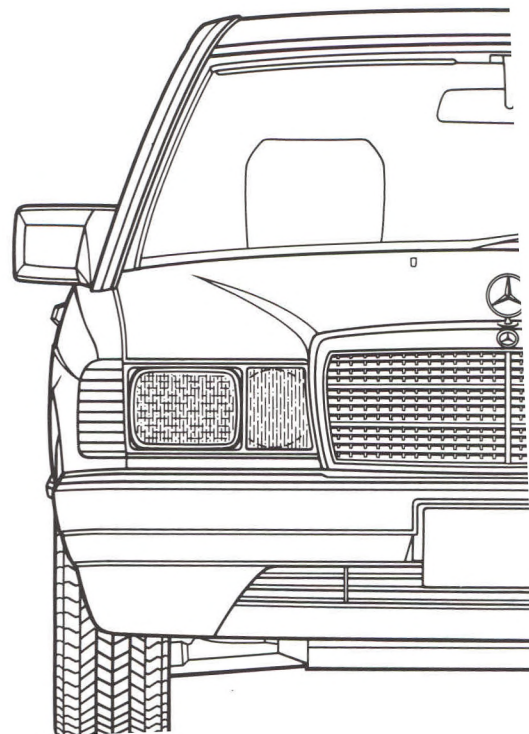

Printed in Germany

We reserve the right to modify the technical details of the vehicle as given in the data and illustrations of this Owner's Manual (s. e. o.). Reprinting, translation and copying, even of excerpts, is not permitted without our prior authorization in writing

ZKD / 2.86.8 / K

Our company and staff congratulate you on the purchase of your new MERCEDES-BENZ.

Your selection of our product is a demonstration of your trust in our company name. Further, it exemplifies your desire to own an automobile that will be as easy to operate as possible and provide years of service.

Your MERCEDES-BENZ represents the efforts of many skilled engineers and craftsmen. To ensure your pleasure in owning it, we ask you to make a small investment of your time:

- Please read this manual carefully before putting it aside.
- Please consider the recommendations contained in this manual. They are designed to acquaint you with the operation of your MERCEDES-BENZ.

We extend our best wishes for many miles of safe, pleasurable driving.

Daimler-Benz Aktiengesellschaft

Introduction

This Owner's Manual contains a great deal of useful information. We urge you to read it carefully and familiarize yourself with the vehicle before driving.

For your own safety and longer service life of the vehicle, we urge you to follow the Instructions and warnings. Ignoring them could result in damage to the vehicle or personal injury.

Your vehicle may have some or all of the equipment described. Therefore, you may find explanations of equipment not installed in your vehicle. If you have any questions about the operation of any equipment, your MERCEDES-BENZ dealer will be glad to demonstrate the proper procedures.

Owner's Service and Warranty Policy

The Owner's Service and Warranty Policy Booklet contains detailed information about the warranties covering your MERCEDES-BENZ, including:

- New Car Limited Warranty
- Emissions Systems Warranty
- Emission Performance Warranty
- California Emission Control System Warranty (California Only)

Maintenance

The Maintenance Booklet describes all the necessary maintenance work which should be performed at regular intervals.

Always have the Maintenance Booklet with you when you take the vehicle to a MERCEDES-BENZ dealer for service. The Service Advisor will record each service.

Roadside Assistance

Although your Mercedes-Benz is built to be as troublefree as possible, a Roadside Assistance Program is available to provide emergency roadside service after normal dealer hours and on weekends and holidays in the contiguous United States.

Roadside Assistance is available Monday through Friday from 5:00 PM to 12:00 Midnight and on Saturday, Sunday and legal holidays from 8:00 AM to 12:00 Midnight. In the event of a breakdown during these hours, telephone this toll-free number: 1-800-222-0100.

For additional information, refer to the Mercedes-Benz Roadside Assistance Program Booklet in your glove compartment.

Change of Address or Ownership

If you change your address, be sure to send in the "Change of Address Notice" found in the Owner's Service and Warranty Policy Booklet. It is in your own interest that we can contact you should the need arise.

If you sell your Mercedes, please leave all owner's literature with the vehicle to make it available to the next owner.

If you bought this vehicle used, be sure to send in the "Notice of Purchase of Used Car" found in the Owner's Service and Warranty Policy Booklet.

Operating Your Vehicle Outside the U.S.A. or Canada

If you plan to operate your vehicle in foreign countries, please be aware that:

- unleaded fuels for vehicles with catalytic converters may not be available; the use of leaded fuels will damage the catalysts,
- fuel may have a considerably lower octane rating, and improper fuel can cause engine damage,
- service facilities or replacement parts may not be readily available.

Certain Mercedes-Benz models are available for delivery in Europe under our European Delivery Program. For details, consult your authorized MERCEDES-BENZ dealer or write to:

Mercedes-Benz of North America, Inc.
European Delivery Department
One Mercedes Drive
Montvale, NJ 07645

**Instruments and Controls, Starting the Engine
Driving Hints, Service and Maintenance**

Operation

Driving

Practical Hints

**Technical Data
Fuels Coolants Lubricants etc.**

Index

Check Regularly and Before a Long Trip

See page 104

What You Should Know at the Gas Station

See last page

The First 1500 km (1000 Miles)

The more cautiously you treat your engine during the break-in period, the more satisfied you will be with its performance later on. Therefore, drive your vehicle during the first 1500 km (1000 miles) at moderate vehicle and engine speeds.

During this period, avoid heavy loads (full throttle driving) and high RPMs (no more than $\frac{2}{3}$ of maximum permissible speed in each gear).

Down shift at proper engine speed!

On vehicles with automatic transmission avoid accelerating by kick-down. It is not recommended to brake the vehicle by manually shifting to a lower gear. We recommend to select positions "3" or "2" only at moderate speeds (for hill driving).

After 1500 km (1000 miles), speeds may gradually be increased to the permissible maximum.

Instruments and Controls, Starting the Engine Driving Hints, Service and Maintenance

Instruments and Controls	10
Instrument Cluster	12
Catalytic Converter Cautions	14
Starting and Turning off the Engine	15
Driving Hints	16
MERCEDES-BENZ Maintenance System	18

Instruments and Controls

For more detailed descriptions see specified pages.

- 1** Air volume lever for side ventilation (page 20)
- 2** Adjustable side ventilation outlets (page 20)
- 3** Exterior lamp switch (page 41)
- 4** Combination switch (page 42)
- 5** Cruise control (page 57)
- 6** Rear passenger compartment lamp switch (page 45)
- 7** Instrument cluster (page 12)
- 8** Horn control, airbag
- 9** Steering lock with ignition/starter switch (page 40)
- 10** Rear window defroster switch (page 45)
- 11** Electric sliding roof switch (page 46)
- 12** Automatic antenna switch (page 52)
- 13** Adjustable center ventilation outlets (page 20)
- 14** Air volume lever for center ventilation (page 20)
- 15** Glove compartment, illuminated (only with key in steering lock positions 1 or 2)
- 16** Air recirculation switch (page 20)
- 17** Fan speed control lever (page 20)
- 18** Tempmatic climate control system (page 20)
- 19** Radio (page 48)
- 20** Ash tray with lighter (page 43, 83)
- 21** Power window switch group (page 47)
- 22** Hazard warning flasher system switch
- 23** Adjusting lever for exterior mirror on front passenger side (page 43)
- 24** Loudspeaker – front to rear fader control
- 25** Left front seat heater switch (page 34)
- 26** Right front seat heater switch (page 34)

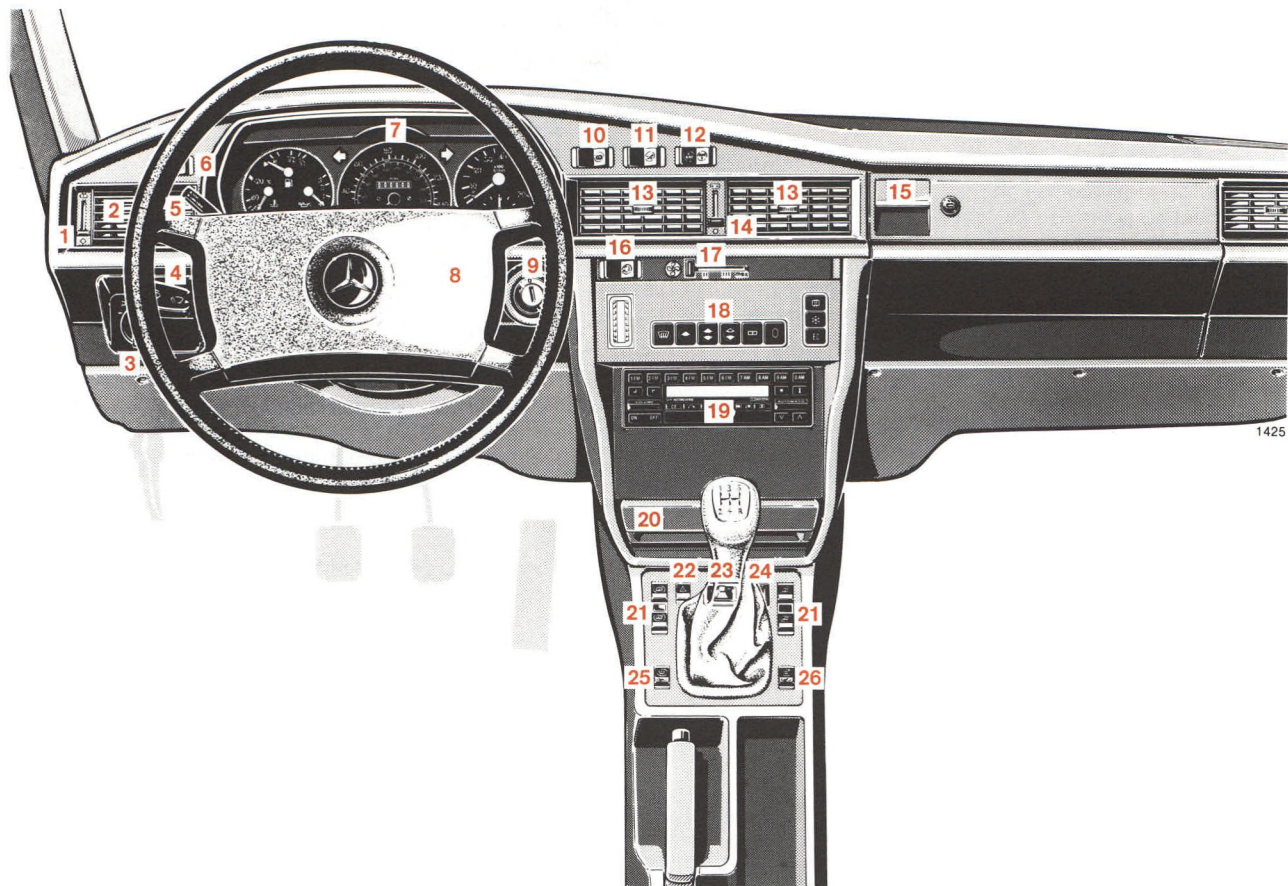

1425

Instrument Cluster

- 1** Economical driving indicator (ECONOMY).
See page 61
- 2** Coolant temperature gauge
Up to red marking: Maximum permissible temperature for an anticorrosion/antifreeze-blended fill protecting down to -30°C (-22°F). See page 60
- 3** Fuel gauge with reserve warning lamp (yellow).
See page 60
Fuel reserve and capacity, refer to page 93 and last page
- 4** Oil pressure gauge (bar). See page 59
- 5** Turn signal indicator lamp, left (green)
- 6** Speedometer
- 7** Main odometer
- 8** Trip odometer
- 9** Turn signal indicator lamp, right (green)
- 10** Tachometer
- 11** Red marking on tachometer:
Excessive engine speed
- 12** Electric clock
- 13** Seat belt warning lamp (red)
- 14** Supplemental restraint system indicator lamp (red).
See page 37
- 15** Antilock brake system (ABS) indicator lamp (yellow).
See page 58
- 16** Low windshield washer level indicator lamp (yellow).
See page 60
- 17** Knob for clock adjustment
(press in for adjustments)
- 18** Outside temperature indicator. See page 60
- 19** Knob for instrument lamps and trip odometer
Rotate knob: instrument lamps intensity are infinitely variable
Depress knob: trip odometer is reset
- 20** Low engine coolant level indicator lamp (yellow).
See page 60
- 21** Low engine oil level indicator lamp (yellow).
See page 59
- 22** Brake warning lamp (red). See page 59
- 23** Brake pad wear indicator lamp (yellow).
See page 59
- 24** Charge indicator lamp (red). See page 59
- 25** High beam indicator lamp (blue)

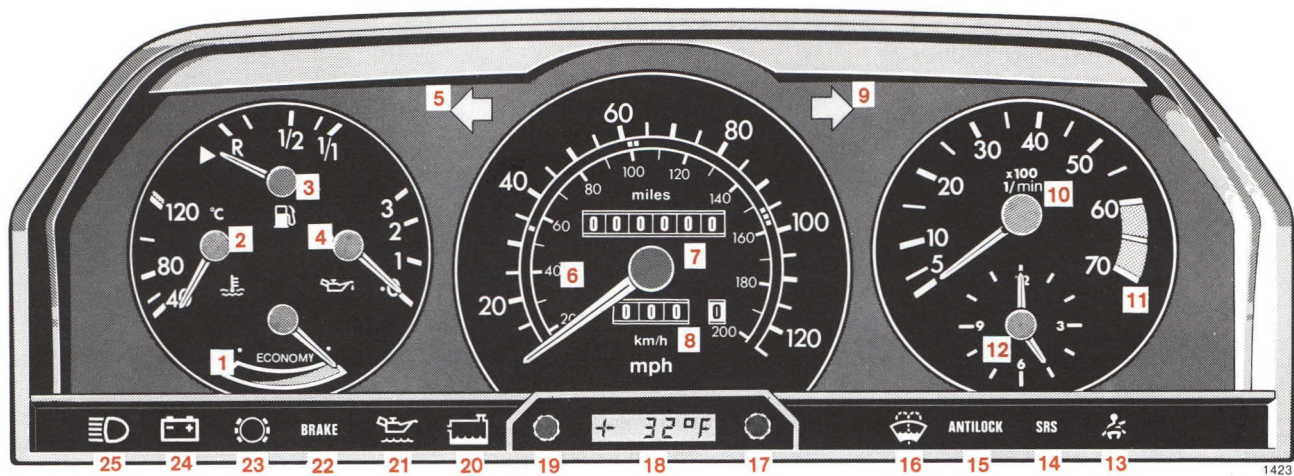

1423



Catalytic Converter Cautions

Your MERCEDES-BENZ is equipped with monolithic catalytic converters, an important element in conjunction with the O₂-sensor to achieve substantial control of the pollutants in the exhaust emissions. Keep your vehicle in proper operating condition by following our recommended maintenance instructions as outlined in your maintenance booklet.

Caution!

To prevent damage to the catalytic converters, only use unleaded gasoline in this vehicle. Should any noticeable irregularities in the engine operation occur, excessive unburned fuel may reach the converter causing it to overheat.

Warning!

As with any vehicle, do not idle, park, or operate this vehicle in areas where combustible materials such as grass, hay or leaves can come in contact with a hot exhaust system, as these materials could be ignited.

Starting and Turning off the Engine

Engage parking brake before starting the engine.

Move gearshift lever to neutral (selector lever positions "P" or "N" on automatic transmissions).

Turn key to steering lock position 2. The charge indicator lamp should come on.

Cold Engine

Turn key in steering lock clockwise to the stop. Do not depress accelerator. Release key only when the engine is firing regularly.

At ambient temperatures of less than -18°C (0°F), depress accelerator three times prior to starting.

Hot Engine

Turn key in steering lock clockwise to the stop. Do not depress accelerator. If the engine has not fired after approx. 4 seconds, depress accelerator and continue cranking until the engine is firing regularly. Release key and back off accelerator.

At very high coolant temperatures the engine starting time can be shortened if the accelerator is depressed slowly at the beginning of the starting process.

Turning off

Turn the key to the steering lock position 0 and remove only when the vehicle has stopped.

If the coolant temperature is very high (e.g. after hard driving on mountain roads), do not shut off the engine immediately, allow it to run for 1–2 minutes at increased idle speed.

Important!

Due to the installed starter non-repeat unit, the key must be returned to steering lock position 0 before a new starting attempt is made.

Observe the oil pressure gauge immediately after starting the engine. In a very cold engine the oil pressure will only rise slowly, some time after the engine has started. Do not speed up the engine before pressure is registered on the pressure gauge.

The charge indicator lamp should go out as soon as the engine has started.

Should too much fuel have entered the engine due to several unsuccessful starting attempts and the engine will no longer fire, depress the accelerator while starting. This should make the mixture combustible again. Back off the accelerator only when the engine is firing regularly.

In areas where temperatures frequently drop below -25°C (-13°F), we recommend that a block heater is installed. Every MERCEDES-BENZ dealer will advise you on this subject.



Driving Hints

Power assistance

When the engine is not running, the brake and steering systems are without power assistance. Under these circumstances, a much greater effort is necessary to steer or stop the vehicle.

Tires

Do not allow your tires to wear down too far. With less than 3 mm ($\frac{1}{8}$ in) of tread, the antiskid properties on a wet road fall off sharply.

Depending upon the weather and/or road surface (conditions), the traction varies widely.

Specified tire pressures must be maintained. This applies particularly if the tires are subjected to high loads (e.g. high speeds, heavy loads, high ambient temperatures).

Aquaplaning

Depending on the depth of the water layer on the road, aquaplaning may occur, even at low speeds. Avoid track grooves in the road and apply brakes cautiously in the rain.

Tire friction

The safe speed on a wet or icy road is always lower than on a dry road.

You should pay particular attention to the condition of the road as soon as the prevailing temperatures fall close to the freezing point.

Warning!

If ice has formed on the road, tire traction will be substantially reduced. Under such weather conditions, drive, steer and brake with extreme caution.

We recommend M + S radial-ply tires for the cold season. On packed snow, they can reduce your stopping distance as compared with summer tires. Stopping distance, however, is still considerably greater than when the road is wet or dry.

Brakes

Warning!

When driving down long and steep grades, relieve the brakes by shifting into a lower speed (selector lever position “3” or “2” in the case of automatic transmissions). This helps prevent overheating of the brakes and reduces brake pad wear.

After hard braking it is advisable to drive on for some time so the air stream will cool down the brakes faster.

Warning!

After driving in heavy rain for some time without applying the brakes or through water deep enough to wet brake components, the first braking action may be somewhat reduced and increased pedal pressure may be necessary. Be sure to maintain a safe distance from vehicles in front.

The condition of the parking brake system is checked each time the car is in the shop for maintenance.

Between maintenance checks it is a good practice to apply the parking brake once or twice while driving at approximately 50 km/h (30 mph) on a dry road. Apply brake lightly until a slight drag on the wheels is felt. Keep applying brakes for about 10 seconds while holding release button in before releasing parking brake completely.

This practice will keep the parking brake at maximum efficiency.

Warning!

The stop lamps will not come on when applying the parking brake only. Perform the procedure in the previous paragraph only when the road is clear of other traffic.

All checks and maintenance work on the brake system should be carried out by an authorized MERCEDES-BENZ dealer.

If the parking brake is released and the brake warning lamp in the instrument cluster stays on, the brake fluid level in the reservoir is too low.

Brake pad wear or a leak in the system may be the reason for low brake fluid in the reservoir.

Have the brake system inspected at an authorized MERCEDES-BENZ dealer without delay.

Install only brake pads recommended by us. If other than recommended brake pads are installed, the braking properties of the vehicle can be affected to an extent that the safety is substantially impaired.

Parking

Warning!

To reduce the risk of personal injury as a result of vehicle movement, before leaving the vehicle always:

- 1. Keep foot on brake pedal.**
- 2. Engage first or reverse gear (selector lever position “P” in the case of automatic transmissions).**
- 3. Turn front wheels towards the road curb.**
- 4. Pull up parking brake lever.**
- 5. Turn the key to steering lock position 0 and remove.**

Winter Driving Hints

The most important rule for slippery or icy roads is to drive sensibly and to avoid abrupt acceleration, braking and steering action. Do not use the cruise control system under such conditions.

When the vehicle is in danger of skidding, declutch or – in case of an automatic transmission – move selector lever to position “N”. Try to keep the vehicle under control by corrective steering action.

Vehicles without ABS:

Provided the traffic conditions will allow, only brake in a way that the wheels are locked for no more than fractions of a second as otherwise the steerability of the vehicle is lost.

Road salts and chemicals can adversely affect braking efficiency. Increased pedal force may become necessary to produce the normal brake effect. We therefore recommend depressing the brake pedal repeatedly when traveling on saltstrewn roads at length. This can bring road salt impaired braking efficiency back to normal. A prerequisite is, however, that this is possible without endangering other drivers on the road.

If the vehicle is parked after being driven on salt treated roads, the braking efficiency should be tested as soon as possible after driving is resumed while adhering to the safety requirements.

MERCEDES-BENZ Maintenance System

A maintenance booklet is included with your car listing all the maintenance jobs that must be carried out after the following mileages:

Routine Maintenance

Inspection at
1300–1600 km (800–1000 miles)

Lubrication Service every
12 000 km (7500 miles)

Maintenance Service every
24 000 km (15 000 miles)

Additional Work every
48 000 km (30 000 miles)

For additional details refer to the Maintenance Booklet.

In the case of low mileage operation, the Maintenance Service must be carried out at least once every 2 years.

Engine Oil and Filter Change

Required every 12 000 km (7500 miles), or at least once a year (fall) when using year-round multi-grade oil; otherwise at least twice a year (spring and fall).

For engine oil recommendations, see page 91.

Severe Operating Conditions

In the case of severe operating conditions or heavy use mainly in city traffic or over short distances, frequent mountain driving, poor roads, dusty and muddy conditions, trailer operation, hard and sporty driving etc., it may be necessary to carry out maintenance work at shorter than normal intervals, as follows:

Engine: Oil change with filter change every 6000 km (3750 miles)

Automatic transmission: Fluid change without filter change every 24 000 km (15 000 miles)

Tires: Inspect

Air cleaner: Clean or replace element

Special Maintenance Measures

Brake fluid should be replaced annually, preferably in the spring.

It is recommended to use only brake fluid approved by MERCEDES-BENZ. Do not mix different types of brake fluids.

The coolant should be checked for sufficient protection before the start of and during the hot and cold season. Have the coolant (water/anticorrosion/antifreeze mixture) replaced at least every three years (see "Fuels, Coolants, Lubricants, etc.").

Maintenance Vouchers

Your authorized MERCEDES-BENZ dealer will certify in the maintenance booklet that all lubrication and maintenance services have been carried out at the correct intervals.

Operation

Tempmatic Climate Control System	20
Car Keys	26
Opening the Doors	27
Locking and Unlocking of Doors	27
Central Locking System	28
Anti-Theft Alarm System	29
Manual Seat Adjustment, Front	30
Adjusting Power Seats, Front	31
Orthopedic Seat Backrest	32
Arm Rest (Front Seats)	33
Arm Rest (Rear Bench Seat)	33
Head Restraints, Rear	33
Heated Seats	34
Supplemental Restraint System – Seat Belts, Emergency Tensioning Retractors, Driver Airbag	35
Steering Lock	40
Exterior Lamp Switch	41
Combination Switch	42
Exterior Mirrors	43
Inside Rear View Mirror	43
Sun Visors	44
Interior Lamps	44
Rear Window Defroster	45
Lighter	46
Sliding Roof	46
Power Windows	47
Shelf below Rear Window	47
Electronic Radio	48

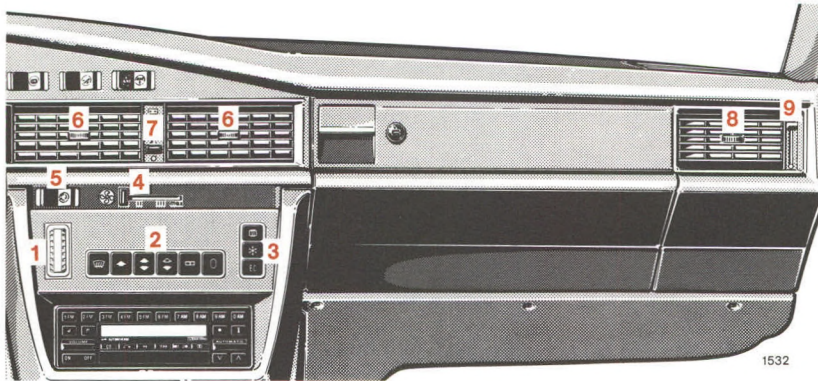

Tempmatic Climate Control System

The engine must be running for the climate control system to work.

1 Temperature selector

2 Air distribution control push buttons (press only one button at a time)

 = Defrost

 = Defog

 = Heating and cooling

 = Normal heating

 = Normal cooling or fresh air ventilation

 = No fresh air supplied

3 Air conditioning mode control (press only one button at a time)

 = Max. cooling

 = Normal setting

 = Economy setting (No A/C)

4 Fan speed control lever

5 Air recirculation switch

6 Instrument panel center outlets

7 Air volume lever for center outlets (6)

8 Instrument panel side outlets

9 Air volume lever for side outlets (8)

The button symbols light up when the vehicle's headlamps are turned on (not with parking lamps). The symbol is brighter when depressed.

Close all windows and the sliding roof to ensure proper operation of the system. Air outlet temperature is controlled automatically.

Note:

The air conditioner removes considerable moisture from the air during operation. It is normal if water drips on the ground from the underbody.

Air Distribution

Air conditioned, warmed, or fresh air may be directed to the foot area, the windshield, and the side outlets (8). The center outlets (6) are for non-heated air only.

The air volume through the center outlets (6) and side outlets (8) can be varied with levers (7) and (9) respectively. Pushing the lever up opens the air outlets completely.



Temperature Selection

 Use the temperature selector to set the desired temperature. The selected temperature is reached as quickly as possible and maintained. Use a basic setting of “22”. Refine your setting only in small steps to avoid large temperature fluctuations.

“MIN” (notched-in) = maximum cooling or fresh air dependent on push button selection of the air conditioning mode control.

“MAX” (notched-in) = maximum heating.

A/C Mode Control Switch

 Position  (Economy) = Economical setting. In this setting the air conditioning compressor stays off.
 Temperature regulation is maintained only during the heating phase.

Position  = Normal cooling, the air conditioning compressor is switched on.

The vehicle may be heated or cooled as desired. The compressor comes on as soon as the vehicle's interior temperature exceeds the selected temperature. The selected temperature is then maintained by regulating the compressor on-time.

Position  = Max. cooling, the air conditioning compressor is switched on.

The climate control system works at maximum capacity, removing moisture from either fresh air or recirculated air and defogs inside glass. The max. cooling mode, is recommended during humid weather and when windows must be defogged from inside.

Fan Speed Selection

When pushing one of these buttons , ,  or button , the fan speed will correspond to the particular position of lever (4).

The volume of fresh air supplied to the vehicle interior can be increased by pushing lever (4) to the right.

The fan speed may be changed by moving lever (4) to position “II”, “III” or “max”. The fresh air intake may be temporarily closed (press push button ) if driving through dusty areas or annoying odors enter the car interior.

Function  = Continuous max. air volume.



Air Recirculation Switch

Pressing the switch (symbol-side) down, causes air to be recirculated with only a small amount of fresh air. The indicator lamp should be on (do not push  button). This setting can also be used if annoying odors are entering the car's interior. At high outside temperatures the air conditioning system is automatically in the recirculation mode, providing increased cooling.

Note:

The air recirculation switch should never be on in  defrost or when inside of glass tends to fog up.

Fast Cooling

- Turn temperature selector wheel (1) and lock in extreme end position “MIN”.
- Push button  or  in mode control (3).
- Push  button.
- Push lever (4) to far right “max” position.
- For maximum air flow push up levers (7) and (9).
- Close windows and sliding roof completely.

Open the windows and/or sliding roof long enough to let hot air inside the car escape. This helps reduce the time the air conditioner must run before the car cools. Then, close windows and/or sliding roof and allow air conditioner to operate normally.

Examples of Air Flow Adjustments

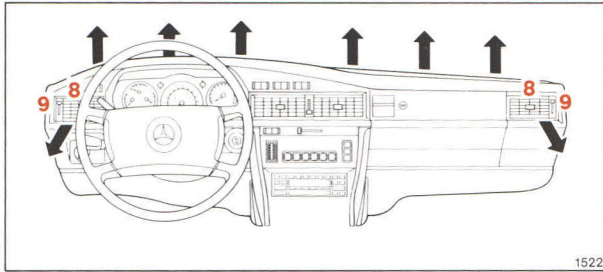



 Press to defrost or quickly defog windows.

Maximum heated air is directed to the windshield and side windows, independent of the temperature setting (1), mode control (3) and lever (4) position. The air volume through outlets (8) may be adjusted with levers (9) as desired.

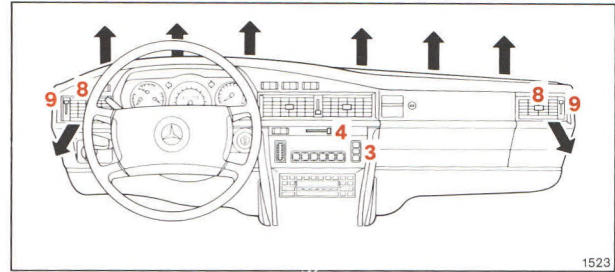
Air recirculation switch must be off.



 Press to defog the windshield from inside.

Air is directed to the windshield in the heating or cooling mode. Press button  of mode control (3) and increase fan speed for a short period with lever (4). Adjust levers (9) for the desired air flow through outlets (8).

It is possible for condensation to form on the outside of the windshield in humid weather in this mode. If this happens, change the air flow or decrease the fan speed.

Air recirculation switch must be off.

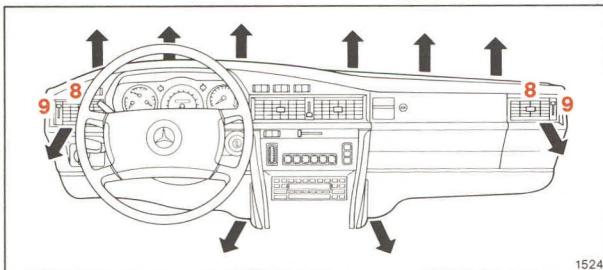

1524

 Press for heating with air conditioned air.

In this type of operation, air is directed to the windshield and the foot area. The air outlets (8) may be opened or closed with levers (9) as desired.

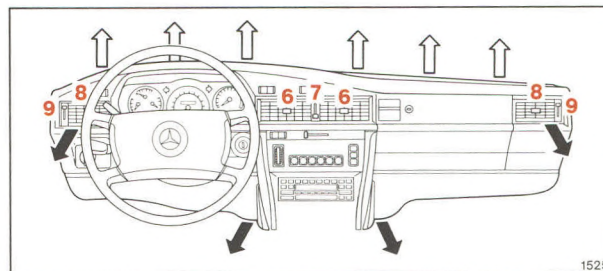

1525

 Press for normal heater operation.

Most of the air is directed to the foot area during heater operation. A small amount of air is directed to the windshield, just enough to keep it from fogging up during normal weather conditions. The air outlets (6) and (8) may be opened or closed with levers (7) and (9) respectively as desired. Only non-heated air is directed through outlets (6).

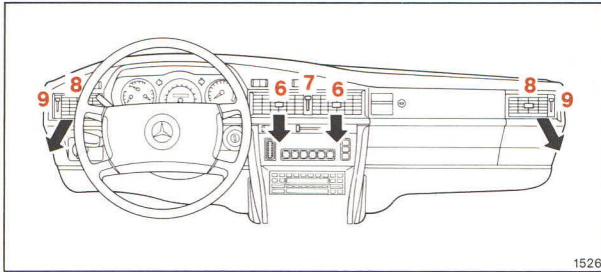

1526

6 Press for fresh air ventilation or air conditioning.

For taking in fresh air or during air conditioner operation, the air is directed to outlets (6) and (8). Adjust the air flow with levers (7) and (9) respectively as desired.

0 Press to shut off air entry.

Fresh air into the vehicle is shut off. Use this button, for example, to prevent outside odors or water from car washes from entering the vehicle's interior. Do not drive the vehicle with this setting for long periods with windows and sliding roof closed since the vehicle's normal interior airflow will be disrupted.

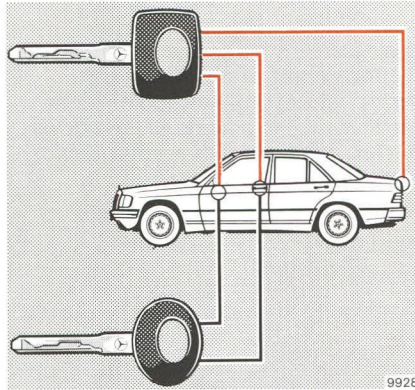

Car Keys

Included with your vehicle are two master keys, one valet key and one flat (master) key.

Master Key – square head with a red dot – fits all locks on the car. Arms/disarms the anti-theft alarm system.

Valet Key – round head – fits only the door locks and the steering lock. This key should be used whenever the car is left with an attendant. Be sure to lock glove compartment and trunk with the master key. The valet key cannot be used to de-activate the anti-theft alarm after the car is locked with the master key.

Flat Key



The flat key with a red dot fits all vehicle locks. Arms/disarms the anti-theft alarm system. We recommend that you carry the flat key with you and keep it in a safe place so that it is always handy (e.g. in your wallet). Never leave the flat key in the vehicle.

Obtaining Replacement Keys

Your car has a theft deterrent locking system. For security reason replacement keys can only be obtained via an authorized MERCEDES-BENZ dealer. Therefore obtaining replacement keys requires considerable time.

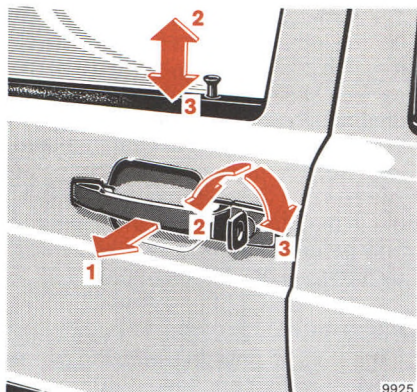

Opening the Doors

From outside: pull handle outwards (1).
From inside: pull handle in door trim panel (4).

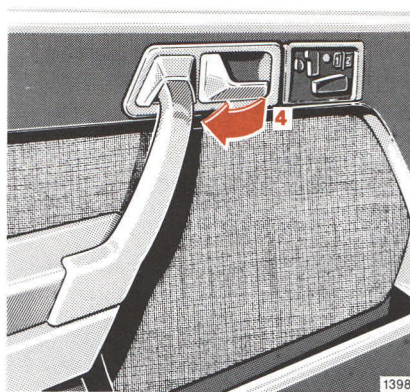

Locking and Unlocking of Doors

From the outside: turn key.
From the inside: actuate door lock button.
2 Unlocking
3 Locking

When the rear door lock buttons are down, the rear doors cannot be opened from the outside or the inside. They can only be opened after pulling the buttons up.

One cannot lock:

- the driver's door if it is open
- any door if the door lock has not engaged fully. In this case open the door and close it again.

Central Locking System

The entire vehicle may be locked or unlocked with the central locking system:

- Using the master or valet key in either front door.
- Using the master key in the trunk lock.
- By pushing down or pulling up the interior door lock button at either front door.

The central locking system locks or unlocks all doors, trunk lid and fuel filler flap simultaneously.

Doors

When you lock the car, all door lock buttons should move down. If any one stays up, the respective door is not properly closed. You should then unlock the car, open and reclose this door, and lock the car again.

Note:

The central locking system can be engaged from the driver-side door lock button, provided the door is completely closed. It can also be engaged from the passenger-side if the ignition key is removed, or engaged in the steering lock without being turned (key in position 0).

If the car has been locked from the outside with the master key, the anti-theft alarm will come on if a door is opened from the inside, or if opened with the valet key.

Trunk

To unlock the trunk with the central locking system, turn the master key in the trunk lock completely to the left and let it return to the normal position. Push in trunk lock button and open the trunk. To lock the trunk, turn the master key completely to the right and let it return to the normal position.

The trunk can remain locked while the central locking system is unlocked (e.g. while driving or when leaving the car in a situation where it must be driven using the valet key but you wish the trunk to remain locked at parking lots, workshops, etc.). Turn the master key completely to the right and pull it out in that position. Now the trunk can only be unlocked with the master key by turning it back to the left.

Important!

If the trunk is unlocked with the central locking system engaged, the doors and fuel filler flap will also be unlocked. After closing the trunk, the central locking system must again be engaged using the key!

Note:

If the fuel filler flap cannot be opened, refer to “Unlocking of Fuel Filler Flap” (page 75).

Anti-Theft Alarm System

The anti-theft alarm can be armed or disarmed with the master key (identified by red dot) by locking or unlocking either front door or the trunk.

Operation

Once the alarm system has been armed, the exterior vehicle lamps will flash and the horn will sound intermittently when someone tries to:

- open a door
- open the trunk
- open the hood
- remove the radio
- switch on or bridge the ignition circuit
- step on the brake pedal
- raise the vehicle, i.e. towing away.

The alarm will last approximately 150 seconds in the form of blinking exterior lamps. At the same time an additional horn will sound intermittently for 60 seconds, pause for 30 seconds, and repeat for another 60 seconds.

The alarm will stay on even if the arming element (a door, for example) is immediately closed.

Note:

If the radio is removed from its mounting when the anti-theft alarm is armed the radio will automatically be rendered inoperative!

To avoid setting off the alarm unintentionally, do not arm the alarm system in the following situations; e.g.: Auto ferry, auto train, when hitching/unhitching a trailer, or heavy loading/unloading. For this purpose use the valet key and not the master key for locking the vehicle.

Special function

To activate the anti-theft alarm from the trunk, turn the master key in the trunk lock completely to the right and pull it out in this position.

If you want the alarm system to be armed at the trunk only, turn the master key in the trunk lock completely to the right and pull it out in that position. Then disarm the rest of the vehicle by unlocking either front door with the master key. You can now lock or unlock the doors and filler flap, as well as start the engine, using the valet key.

Do not give the master key to an unauthorized person. We recommend that you carry the flat key safely with you (e.g. in your wallet so that it is always handy). This key has the same function as the master key.

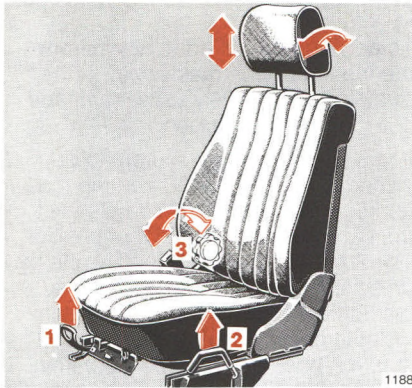

Manual Seat Adjustment, Front

Fore/aft adjustment: lift handle (1); slide seat to desired position and allow handle to re-engage.

Height of seat: raise lever (2); to raise seat, slide seat forward; to lower seat, slide seat backward; allow lever to re-engage.

Seat back position: turn handwheel (3). For full reclining of backrest, seat should be moved to one of the forwardmost positions and head restraint removed. For driving, return backrest to upright position and push seat back. Replace head restraint.

Head restraint: to adjust the height of the head restraint, pull it slightly forward while lifting or pushing down. Adjust head restraint to support the back of the head approximately at ear level. However, do not pull up the head restraint past the detent.

To remove head restraint refer to "Practical Hints".

Warning!

Do not adjust the driver's seat while driving. Adjusting the seat while driving could cause the driver to lose control of the vehicle.

Never ride in a moving vehicle with the seat back reclined. The seat back and seat belts provide the best restraint when the wearer is in an upright position and the belts are properly positioned on the body.

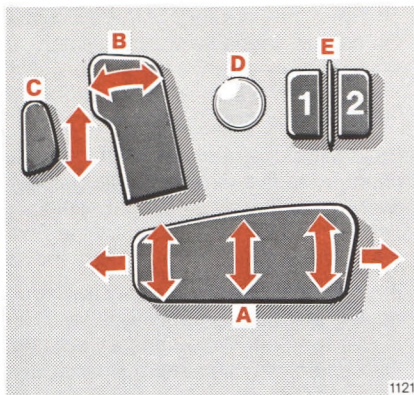

Adjusting Power Seats, Front

The switches are located in each front door.

Turn key to steering lock position 1 or 2 (with the driver's door opened, the power seats can also be operated with the key removed or in steering lock position 0).

Seat and head restraint adjustment:

- A Seat cushion adjustment
- B Seatback adjustment
- C Head restraint adjustment

Adjust head restraint to support the back of the head approximately at ear level. The head restraint can also be turned forward by hand.

Note:

If the car is equipped with power head restraints, do not try to operate manually.

Warning!

Do not adjust the driver's seat while driving. Adjusting the seat while driving could cause the driver to lose control of the vehicle.

Never ride in a moving vehicle with the seat back reclined. The seat back and seat belts provide the best restraint when the wearer is in an upright position and the belts are properly positioned on the body.

Storing seat and head restraint positions in memory:

- D Memory button.
- E Position buttons "1" and "2".

Two sets of seat/head restraint positions may be programmed in memory. After the seat and head restraints are positioned, push memory button D, and within 3 seconds push position button "1". The second set of positions for the seat and head restraint can be stored by pushing position buttons D and "2".

Recalling seat and head restraint positions stored in memory:

To recall a seat/head restraint position, push position button "1" or "2" until seat/head restraint movement has stopped. For safety reasons, the seat/head restraint movement stops after releasing the position button.

Caution!

Do not remove head restraints except when mounting seat covers. For removal refer to "Practical Hints". Whenever restraints have been removed be sure to reinstall them before driving.

Important!

Prior to operating the vehicle, the driver should adjust the seat height for proper vision as well as fore/aft placement and seat back angle to insure adequate control, reach, operation, and comfort. The head restraint should also be adjusted for proper height.

Both the inside and outside rear view mirrors should be adjusted for adequate rearward vision. Fasten seat belts. Infants and small children should be seated in a properly secured restraint system that complies with Federal Motor Vehicle Safety Standard 213.

All seat, head restraint, and rear view mirror adjustments as well as fastening of seat belts should be done before the vehicle is put into motion.

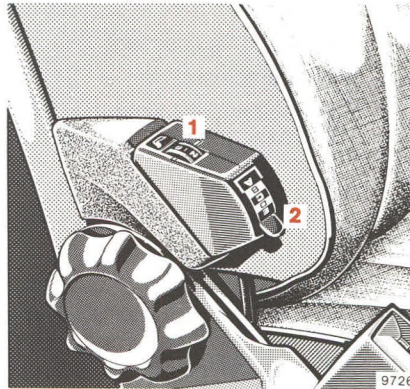

Orthopedic Seat Backrest

Some models may be equipped with orthopedic seats. These seats have an inflatable air cushion built into the backrest to provide additional lumbar support. The amount of cushion height and curvature may be adjusted after turning the key to steering lock position 2.

The inflation pressure of the air cushion can be varied between position "0" = without pressure, and position "4" = maximum pressure, by changing the pressure regulator (1) setting.

In addition, the cushion height may be changed to five different settings between position "A" = lowest setting, and "E" = highest setting, by varying the height regulator (2) adjustment.

If a driving trip is temporarily interrupted, the last cushion setting is retained in memory, and automatically adjusts the cushion to this setting when the trip is continued.

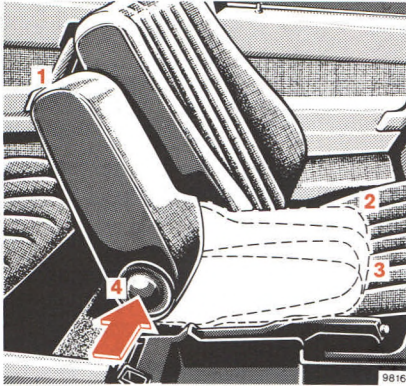

Arm Rest (Front Seats)

The arm rest engages in 3 positions.
 Position 1 = arm rest folded up.
 Position 2 = for normally inclined seat back.
 Position 3 = for extremely inclined seat back.

For downward adjustment of the arm rest, depress release button (4).

Warning!

The arm rest does not suffice as a child restraint system. In case of a frontal collision a child can be catapulted forward over the locked arm rest.

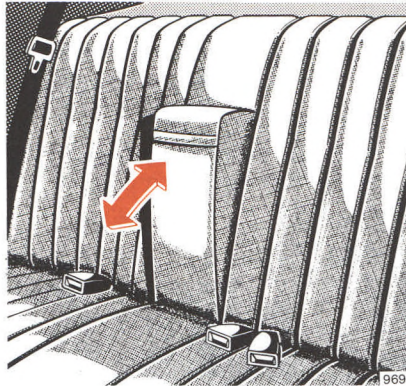

Arm Rest (Rear Bench Seat)

The rear seat is equipped with an arm rest, which may be pulled out by the loop.

For removal of rear seat cushion, see "Practical Hints".

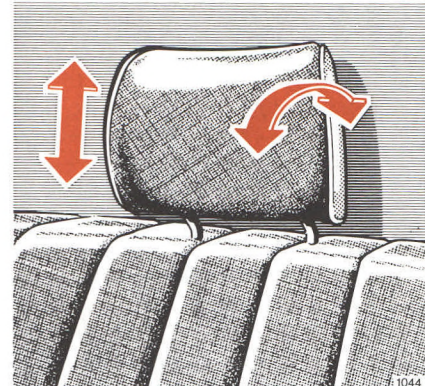

Head Restraints, Rear

Adjust head restraint to support the back of the head approximately at ear level. Do not extend the head restraint past the stop.

For removal of head restraint refer to "Practical Hints".

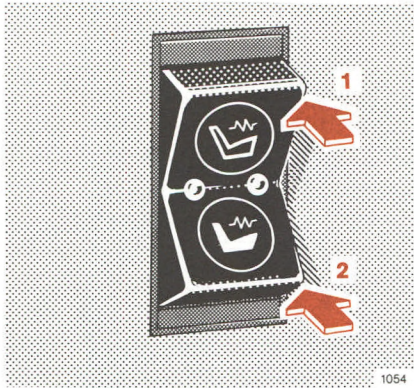

Heated Seats

The seat heaters can be switched on with the key in steering lock position 2.

Heater operation:

Push in upper switch portion; position 1 = normal heater operation, one indicator lamp lights up.

Push in lower switch portion; position 2 = rapid heating, both indicator lamps light up.

After approximately 5 minutes in the rapid heating mode, the heater automatically switches to normal operation and only one indicator lamp will stay on.

Turning off heater:

If one indicator lamp is on, press in upper part of switch, position 1.

If both indicator lamps are on, press in lower part of switch, position 2.

The heater automatically turns off after approximately 30 minutes of operation.

Note:

When in operation, the seat heater consumes a large amount of power. It is advisable not to use the seat heater longer than necessary.

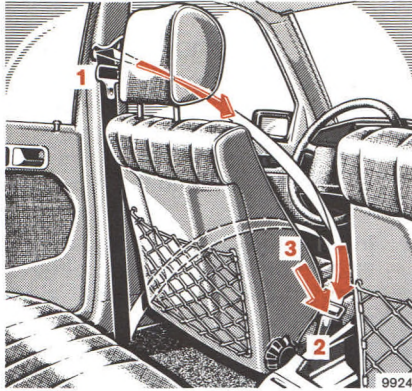

Supplemental Restraint System – Seat Belts, Emergency Tensioning Retractors, Driver Airbag

Seat Belts and Emergency Tensioning Retractor

Your vehicle is equipped with seat belts for all seats and emergency tensioning retractors for front seats. The tensioning retractors are located in each belt's inertia reel and become operationally ready with the key in steering lock position 1 or 2.

Important!

Laws in your state may require seat belt use.

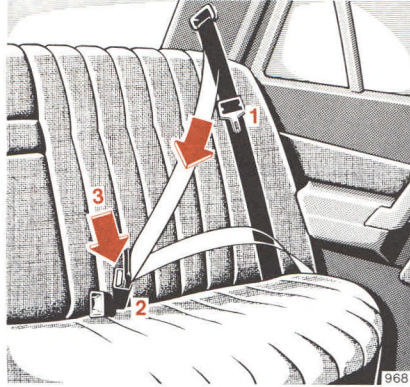

Warning system:

The indicator is illuminated for 4–8 seconds after turning the key to steering lock position 2. If the seat belt of the driver's seat is not fastened a warning buzzer sounds simultaneously.

Fastening:

- Pull belt with latch plate (1) over shoulder and lap. Do not twist the belt doing this.

- Push latch plate (1) into buckle (2) until it clicks.
- The belt must be pulled snug and checked for snugness immediately after engaging it and during driving. If necessary, tighten the lap portion to a snug fit by pulling shoulder portion up.

Unfastening:

- Push in the red button (3) in the belt buckle.
- The retractor should completely rewind the belt and latch plate (1).

Operation:

The inertia reel stops the belt from unwinding during sudden vehicle stops or when quickly pulling on the belt.

The emergency tensioning retractor tightens the seat belt upon severe frontal impacts within the shaded area shown on page 36.

The locking function of the reel may be checked by quickly pulling out the belt.

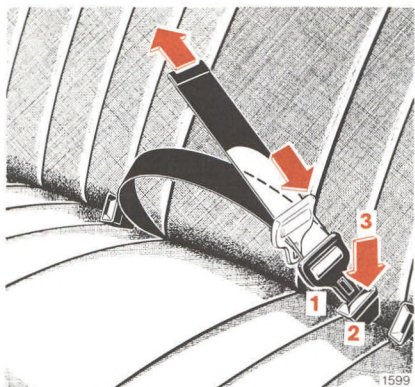

Lap belt for middle of rear seat:

Pull belt with latch plate (1) across the lap, press latch plate into buckle (2) until it clicks. The belt must not be twisted and must be tight.

To shorten the belt: with the latch plate engaged, pull the loose end of the belt.

To lengthen the belt: with the belt unfastened, turn the latch plate so that it is a little more than 90° to the belt, then extend the belt. Fasten the belt and shorten as stated above.

To disengage the belt, push red button (3) in buckle.

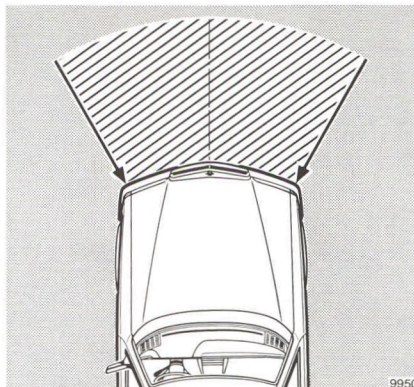

The emergency tensioning retractors are designed to activate only during severe frontal impacts within the shaded area shown. They tighten the belts in such a way that they fit more snugly against the body restricting as much as possible its forward movement.

In cases of less severe frontal impacts, such as roll-overs, side or rear collisions, or other accidents without severe frontal forces, the emergency tensioning retractors will not be activated. The driver and passengers will then be protected by the fastened seat belts and inertia reel in the usual manner.

Warning!

- All occupants should wear seat belts at all times. Never wear the shoulder belt under your arm or otherwise out of position. Position the lap belt as low as possible around the hips (not the waist).
- Infants and small children should be seated in a properly secured child or infant restraint system.
- Seat belts should not be used for more than one person at a time.
- Belts should not be worn twisted.
- Pregnant women should select a seat with a lap-shoulder belt whenever possible. The lap belt should be positioned as low as possible around the hips, to avoid any possible pressure on the abdomen.

For cleaning and care of the seat belts, see page 82.

For seat belt and emergency tensioning retractor safety rules, see page 38.

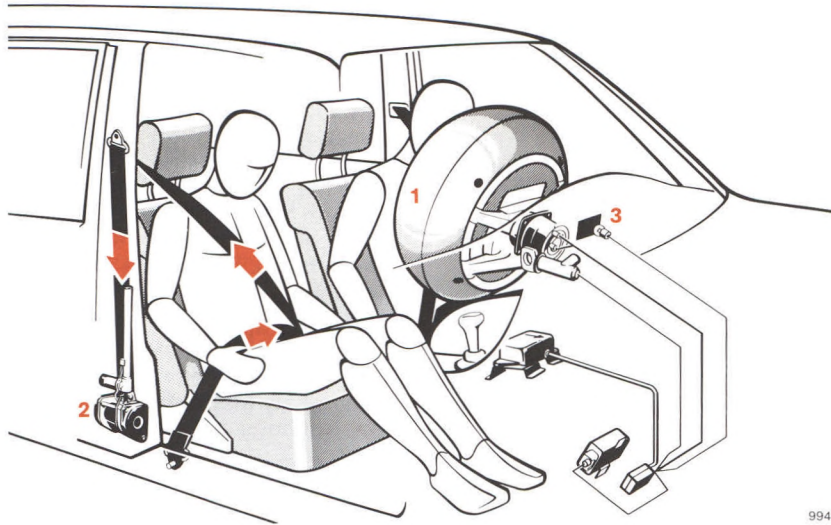

9949

Driver Airbag

The airbag (1) is located in the steering wheel hub and, in conjunction with wearing the seat belts with emergency tensioning retractors (2), provides increased protection for the driver.

The operational readiness of the supplemental restraint system (airbag) is verified by the indicator lamp "SRS" (3) in the instrument cluster. With the key in steering lock position 1 or 2, the indicator lamp comes on for about 10 seconds then goes out. If it doesn't

come on, doesn't go out, flickers on and off, or comes on while driving, the system is malfunctioning.

This will not cause the supplemental restraint system to be activated. However, we strongly recommend that you visit an authorized MERCEDES-BENZ dealer immediately to have the system checked; otherwise the "SRS" may not be activated in a severe frontal accident.

The airbag is designed to activate only in severe frontal impacts within the shaded area shown in the illustration on page 36. Only during these types of impacts will it provide its supplemental protection. The driver should always wear the seat belt, otherwise it is not possible for the airbag to provide its intended protection.

In cases of less severe frontal impacts, roll-overs, side or rear collisions, or other accidents without severe frontal forces, the airbag will not be activated. The driver and other passengers will then be protected by the fastened seat belts.



The activation of the “SRS” temporarily releases a small amount of dust from the driver airbag and all of the seat belt emergency tensioning retractors. This dust, however, is neither injurious to your health, nor does it indicate a fire in the vehicle.

The service life of the airbag extends to the date indicated on the sticker on the inside of the glove compartment door and on the radiator support in the engine compartment. To provide continued reliability after that date, it should be inspected by an authorized MERCEDES-BENZ dealer at that time.

Safety Guidelines for the Supplemental Restraint System – Seat Belts, Emergency Tensioning Retractor and Airbag

Warning!

- **Damaged belts or belts that were highly stressed in an accident must be replaced and their anchoring points must also be checked. Use only belts installed or supplied by MERCEDES-BENZ.**
- **Do not pass belts over sharp edges.**
- **Do not make any modification that could change the effectiveness of the belts.**
- **An airbag or tensioning retractor that was activated must be replaced.**
- **No modifications of any kind may be made to any components or wiring of the “SRS”. This includes the installation of additional trim material, badges, etc. over the steering wheel hub and installation of additional electrical/electronic equipment on or near “SRS” components and wiring.**

- **Improper work on the system, including incorrect installation and removal, can lead to possible injury through an uncontrolled activation of the “SRS”. In addition, through improper work there is the risk of rendering the “SRS” inoperative. Work on the “SRS” must therefore only be performed by an authorized MERCEDES-BENZ dealer.**
- **When scrapping the airbag unit or emergency tensioning retractor, it is mandatory to follow our safety instructions. These instructions are available at every authorized MERCEDES-BENZ dealer.**

When you sell the vehicle we strongly urge you to give notice to the subsequent owner that it is equipped with an “SRS” by alerting him to the applicable section in the Owner’s Manual.

Infant and Child Restraint Systems

Mercedes-Benz of North America recommends that all infants and children be restrained at all times while the vehicle is in motion.

Important!

The use of infant or child restraints is required by law in most states.

Infants and children should be seated in a properly secured restraint system that complies with U.S. Federal Motor Vehicle Safety Standard 213. A statement by the seat manufacturer of compliance with this standard can be found on the instruction label on the restraint and in the instruction manual provided with the restraint.

When using any infant or child restraint system, be sure to carefully read and follow all manufacturer's instructions on installation and use.

Warning!

Infants and small children should never be held on the lap, nor should they share a seat belt with another occupant while the vehicle is in motion.

This vehicle is equipped with tether anchorages for use with child restraints that have a top tether strap. Consult your local dealer for the exact location of these anchorages.

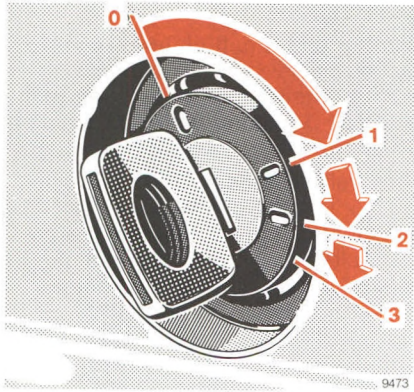

Steering Lock

- 0 Steering is locked when the key is withdrawn and the steering lock is engaged. The key can be withdrawn only in position 0.

Warning!

Do not remove key from the steering lock while the vehicle is in motion as this will cause the engagement of the steering lock thus rendering the vehicle inoperable.

- 1 Steering is unlocked.
(If necessary, move steering wheel slightly to turn the key clockwise to position 1.)
- 2 Driving position.
- 3 Starting position.

For starting and turning off the engine, refer to page 15.

Notes:

The following items can be operated with the key in steering lock position 1:

Wiper, windshield washer, headlamp flasher, electric lighter, glove compartment lamp, radio, sliding roof, rear window defroster, power windows, power seats.

A warning buzzer sounds when the driver's door is opened with the key in steering lock position 1 or 0.

With the engine at idle speed, the charging rate of the alternator (output) is limited.

It is therefore recommended to turn off unnecessary electrical consumers while driving in stop and go traffic. This precaution helps to avoid draining of the battery.

Unnecessary strain on the battery and charging system may be minimized by turning off the following power consumers, for example:

Heated seats, rear window defroster.

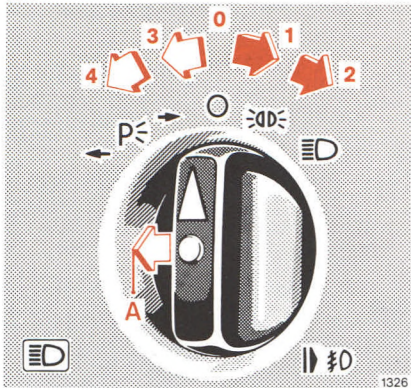

Exterior Lamp Switch

- 0 Off-position
- 1 Parking lamps (includes side marker lamps, taillamps, license plate lamps, instrument panel lamps)
- 2 Same as pos. 1 plus headlamps
- 3 Standing lamps, right
- 4 Standing lamps, left
- A Turn to position 1 or 2 and pull out to first stop = same as position 1 or 2 plus fog lamps.

Standing lamps

When the vehicle is parked on the street the standing lamps (right or left side parking lamps) can be turned on, making the vehicle more visible to passing vehicles.

The standing lamps can only be operated with steering lock in position 0 or 1.

Notes:

With the key removed and the driver's door open, a warning buzzer sounds if the vehicle's exterior lamps are not switched off (standing lamps excepted).

Fog lamps will operate together with low or high beam headlamps. Consult your state Motor Vehicle Regulations regarding fog lamp operation.

Fog lamps are turned off automatically when the exterior lamp switch is returned to off-position.

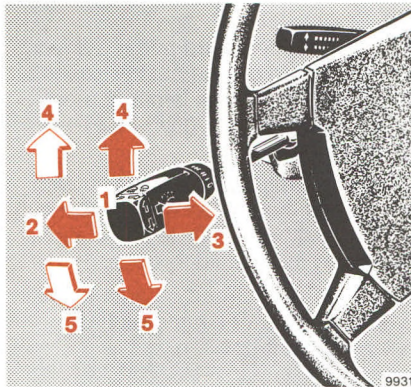

Combination Switch

- 1 Low beam (with exterior lamp switch turned to position 2)
- 2 High beam (with exterior lamp switch turned to position 2)
- 3 High beam flasher (high beam available independent of exterior lamp switch position)
- 4 Turn signals, right
- 5 Turn signals, left

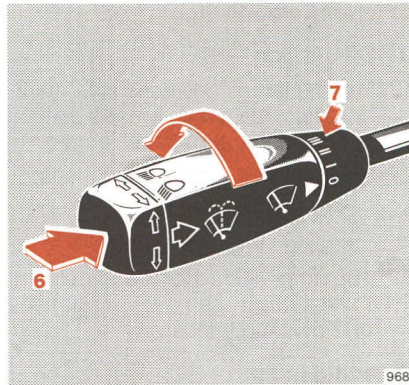

- 6 Control for windshield washer system
When the washer system is activated, the wiper also operate for a limited time.
- 7 Windshield wiper control
 - 0 Windshield wiper switched off
 - I Intermittent wiping
 - II Normal wiper speed
 - III Fast wiper speed

Note:

If one of the turn signals fails, the turn signal indicator system flashes and sounds at a faster rate than normally.

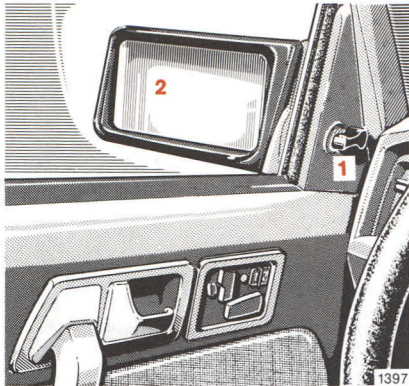

Exterior Mirrors

The exterior mirrors have electrically heated glass. The heater switches on and off automatically, depending on outside temperature.

Driver's side:

The exterior mirror (2) can be adjusted from inside the vehicle by moving adjusting lever (1) in the desired direction.

Passenger side:

The passenger side exterior mirror is convex (curved surface). Exercise care when using the passenger side mirror. See warning imprint on mirror.

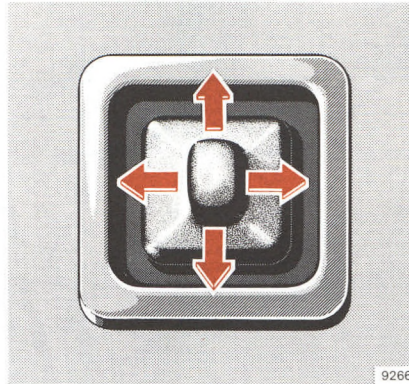

To adjust the mirror:

Turn key to steering lock position 2. The exterior mirror can be adjusted using the switch. Adjust the mirror so you can just see the side of your vehicle in the portion of the mirror closest to the car.

Note:

If the mirror housing is forcibly pivoted from its normal position, it must be repositioned by applying firm pressure until it snaps into place.

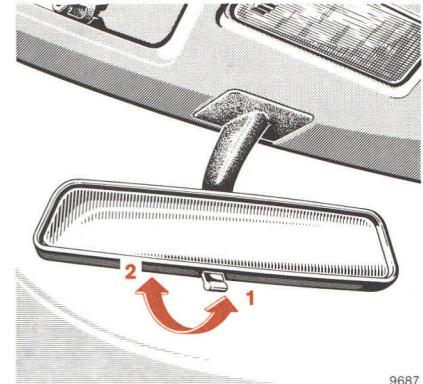

Inside Rear View Mirror

The mirror can be tilted to the anti-glare night position using the lever at its lower edge.

1 = Normal position

2 = Anti-glare night position.

Use your inside mirror to determine the size and distance of objects seen in the convex mirror.

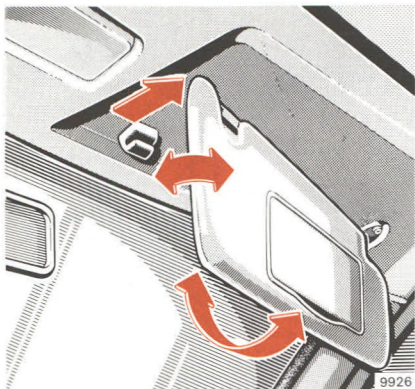

Sun Visors

Swing sun visors down to protect against sun glare.

If sunlight enters through the side window, disengage visor from inner mounting and swing to the side.

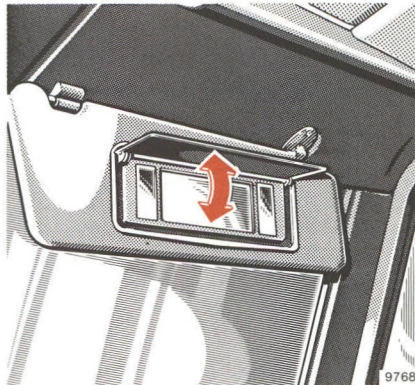

Vanity mirror:

Swing down sun visor. The lamps are switched on when the cover is opened. For this purpose the visor must be engaged in its inner mounting.

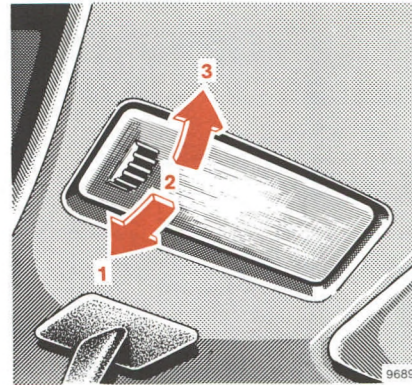

Interior Lamps

The switch for the front lamp has 3 positions.

Position 1: the lamp is switched on and off (delayed) by the front door contact switches.

Position 2: lamp switched off continuously.

Position 3: lamp switched on continuously.

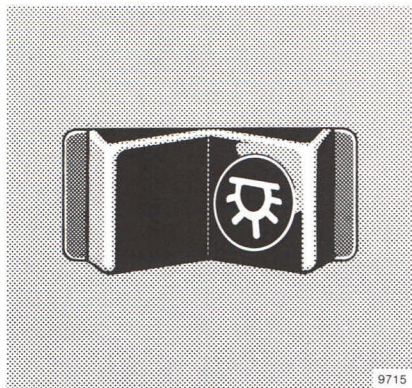

The rear courtesy lamp is switched on and off by the rear door contact switches or by the rocker switch on the instrument panel.

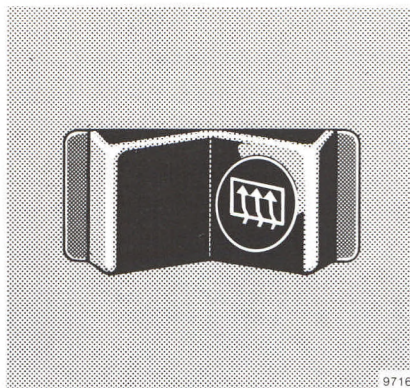

Rear Window Defroster

With engine running, press symbol side of rocker switch to turn on, press left side to turn off.

When activating the rear window defroster, the indicator lamp inside the switch will come on.

Note:

The rear window defroster uses a large amount of power. To keep the battery drain to a minimum, turn off the defroster as soon as the window is clear. The defroster is automatically turned off after a maximum of 20 minutes of operation. Heavy accumulation of snow and ice should be removed before activating the defroster.

If several power consumers are turned on simultaneously, or the battery is only partially charged, it is possible that the defroster automatically turns itself off. When this happens, the indicator lamp inside the switch starts blinking. As soon as the battery has sufficient voltage, the defroster automatically turns itself back on.

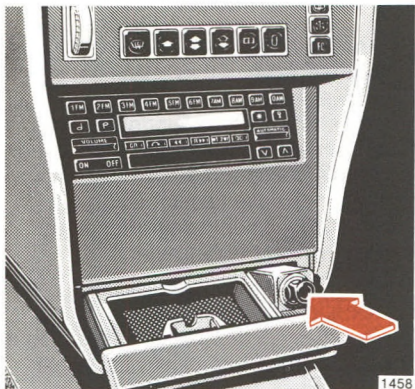

Lighter

Turn key to steering lock position 1 or 2.

Press in lighter; it will pop out automatically when hot.

Warning!

Do not touch heating element or sides of lighter, hold at knob only.

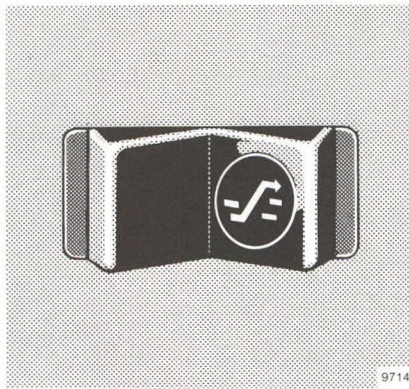

Sliding Roof

Turn key to steering lock position 1 or 2.

Press symbol-side of rocker switch to open roof. Press left side to close roof.

The sliding roof can be opened or closed manually should an electrical malfunction occur. Refer to "Emergency Operation of Sliding Roof" (page 79).

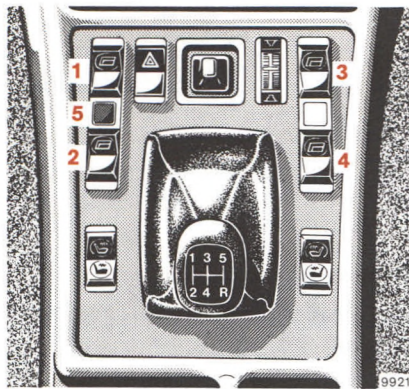

Power Windows

Switch group for power windows:

- 1 left, front
- 2 left, rear
- 3 right, front
- 4 right, rear
- 5 Safety switch

The power windows can only be operated with the key in steering lock position 1 or 2.

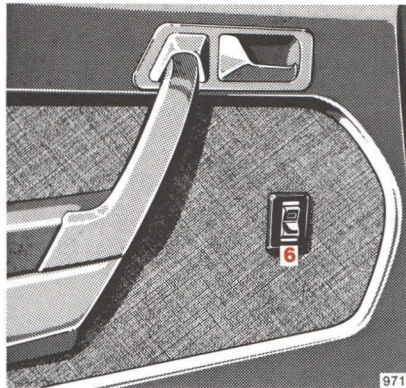

Shelf below Rear Window

Warning!

The shelf below the rear window should not be used to carry objects. This will prevent such objects from being thrown about and injuring vehicle occupants during an accident or sudden maneuver.

All four windows can then be operated using the switches in the center console. The rear door windows can also be operated using the switches (6) in each rear door panel as long as the safety switch (5) in the center console is depressed. If the safety switch is not depressed, inadvertent operation of the rear door windows (for instance, by children) is prevented.

Warning!

When leaving the car always remove the key from the steering lock. Do not leave children unattended in the vehicle. Unsupervised use of power windows can cause serious personal injury.

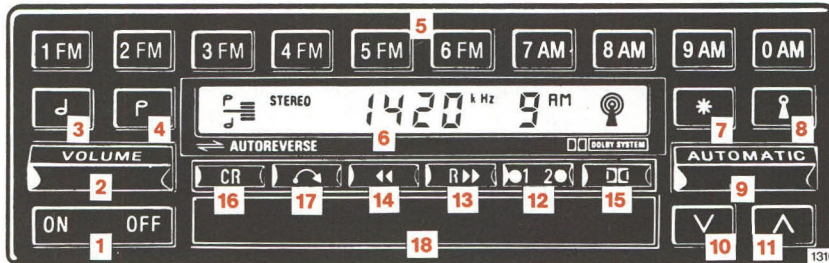

Electronic Radio

Pushbutton Functions

- 1 On/Off button **ON OFF**
- 2 Volume control **VOLUME**
- 3 Bass control **B**
- 4 Treble control **T**
- 5 Pushbuttons for AM/FM band selection, station frequency selection, station storage **1 FM** through **0 AM**
- 6 Digital display for station frequency (a), station pushbutton number (b), AM/FM band (c), stereo indicator (d), tone setting indicator (e), tuning sensitivity indicator (f)

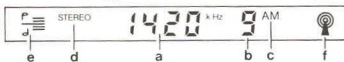

- 7 Function control
- 8 Tuning sensitivity
- 9 Automatic station seeker bar
- 10 Manual tuning **▼** (decreasing station frequency)
- 11 Manual tuning **▲** (increasing station frequency)
- 12 Cassette track selector and track indicator **1 2**
- 13 Fast tape rewind **R▶▶**
- 14 Fast tape forward **◀◀**
- 15 Dolby* noise reduction **DD**
- 16 Tape selection **CR**
- 17 Cassette eject **⤴**
- 18 Cassette door

* Dolby and the double-D symbol are trademarks of Dolby Laboratories Licensing Corporation. Noise reduction system manufactured under license from Dolby Laboratories Licensing Corporation.

To turn the radio ON

Press “ON” side of **ON OFF** button. The radio will begin operating on the last station, volume and tone setting stored before the last turn off.

The system can also be turned on by inserting a tape cassette through the cassette door.

To turn the radio OFF

Press the “OFF” side of the **ON OFF** button.

Volume adjustment

To reduce volume, press volume button **VOLUME** downward; to increase volume, press volume button **VOLUME** upward.

A fader control, installed in the center console, allows for balancing the sound level between the front and rear speakers.

To adjust the tone characteristic

Base and treble can be adjusted independently.

To set the radio to a “flat” tone setting (bass and treble at mid-range setting), briefly press both tone controls **B** **P** simultaneously.

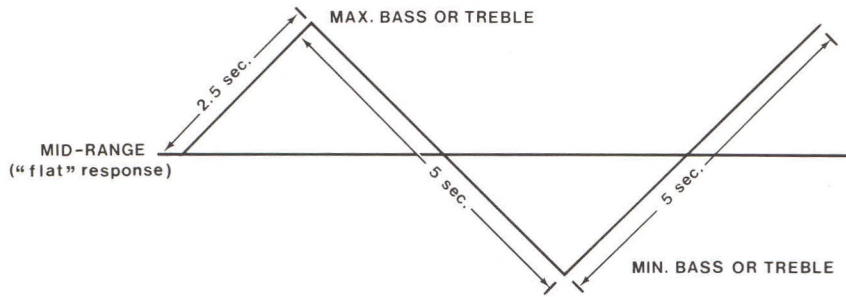

Upon pressing either tone button, the tone level for that function (either bass **B** or treble **P**) will begin increasing. It stops increasing when the button is released or when the maximum tone level is reached (approx. 2.5 seconds).

After reaching the maximum tone level, the tone control will stay at that level unless the tone button is released and pressed again, at which point the tone level will start decreasing. It will stop decreasing when the button is released or when the minimum tone level is reached (approx. 5 seconds).

After reaching the minimum tone level, the tone control will stay at that level unless the tone button is released and pressed again. After pressing the tone button again the tone level will begin to increase and the cycle is repeated.

Adjustments made to the tone characteristics can be observed on the tone setting indicator in the display.

Note: It takes approx. 5 seconds to go from minimum tone level to maximum tone level.

To select AM or FM

Press any of the buttons marked **1 FM** through **6 FM** to tune the radio to the FM band.

Press any of the buttons marked **7 AM** through **0 AM** to tune the radio to the AM band.

The selected wave band is shown in the digital display.

To tune in a station

Stations can be tuned in by using automatic seek, direct frequency tuning, manual tuning, or by preset pushing-buttons. The frequency of the station selected is indicated on the digital display.



Automatic station seeker

Switch to the wave band desired by pressing any of the following buttons: for FM, buttons **1 FM** through **6 FM**, for AM, buttons **7 AM** through **0 AM**.

By pressing the automatic station seeker bar **AUTOMATIC** upward the radio will seek stations in ascending frequencies, by pressing down it will do so in descending frequencies. The direction of automatic seeking can be reversed by pressing the bar **AUTOMATIC** in the respective direction. In order to arrive at a desired station without stopping, the bar must be held in the desired direction.

Tuning sensitivity button

By pressing the tuning sensitivity button  once or twice, you can select the desired sensitivity level of the automatic station seeker. The sensitivity indicator shows the selected sensitivity level:

-  = least sensitive (the automatic seeker only stops at strong stations)
-  = average (the automatic seeker stops at strong and moderate strength stations)
-  = most sensitive (the automatic seeker also stops at weak stations)













When switched off, the radio returns to the “least sensitive” level.

Direct frequency tuning

In order to select a station with a known frequency, select the wave band (AM or FM), press the function control button  and then enter the frequency by pressing the corresponding pushbuttons.

Example:

Press any button marked

FM 98.5 MHz			AM 1050 KHz			
	through			through		
						
						

Press the function control button

Enter frequency by pressing

When tuning a frequency directly, the number of the pushbutton is not displayed on the panel. The wave band is indicated by showing “MHz” for FM or “KHz” for AM.

Note:

All AM stations have allocated frequencies ending with a “0”.

All FM stations have allocated frequencies ending with an odd (uneven) digit after the decimal point.



Broadcasters sometimes may not give their exact frequency but the next closest whole number.

US radio frequency ranges:

AM 540 – 1600 KHz

FM 88.1 – 107.9 MHz





Manual tuning (used to fine tune a station or for manual scanning)

After selecting the desired AM or FM wave band, press the manual tuning button  (decreasing station frequency) or  (increasing station frequency).

The frequency will increase or decrease respectively in increments of 0.1 MHz for FM or 1.0 KHz for AM. Release the button when the desired station is tuned in.

Please note: It is recommended that manual tuning operations be performed by the driver while the vehicle is not in motion.

Pushbutton tuning

Six FM stations and four AM stations can be stored in memory and recalled by pressing the appropriate buttons marked  through  for FM or  through  for AM stations.

To store stations in memory

Any FM station can be stored on any button marked  through  by first tuning in the desired station, depressing the button desired and holding it until the display has changed from the “old” setting to a “blank” and then to the new station to be stored.

Showing the “old” setting first allows for reconsideration of the decision to store. If it is desirable to leave the “old” station in memory rather than exchanging it with the “new” one, quickly release the button. The “old” station will remain in memory.

Any AM station can be stored similarly on any button marked **7 AM** through **0 AM**.

Stereo reception

The stereo indicator **STEREO** lights up if a stereo program in the AM or FM band is received.

Note: Since some AM stereo broadcasting is not compatible with your car radio reception capabilities, you may experience limited AM stereo reception in some areas. The radio receives AM stereo programs which are broadcast via the C-Quam AM stereo system.

The radio is equipped with an automatic stereo/mono switch that electronically switches to mono for clear reception if a weak signal is received.

The stereo indicator will remain lit even if the receiver has changed to the mono mode and will turn off at an antenna signal considered insufficient to provide acceptable reception quality.

Note: Although FM is normally static free, reception quality can be limited by geographic and atmospheric conditions, station strength and distance from transmitter. Buildings or other obstructions can cause momentary static, flutter or station swapping. If good reception cannot be obtained, tune to a stronger station.

Tape cassette playback



It is recommended to use only good quality cassettes with a playback time of not more than 90 minutes (C 90).

To start playback, insert a cassette (tape side first, side “1” or “A” facing up) through the cassette door. Push the cassette in until it is locked in its playing position.

When the end of one playing side is reached, the unit switches automatically to reverse for playing the second track.

The tape track can be selected by depressing the cassette track button **1 2**. The built-in indicators show which track of the cassette the unit is playing back.

To stop playback, press the eject button . The unit will automatically eject the cassette and switch to radio reception.

For fast tape rewind press the fast rewind button . The button will lock into position until the end of the tape is reached or until the eject  or fast forward button  is activated.

Accordingly, for fast forward of the tape, press the fast forward button .

To replay cassettes recorded using the Dolby B noise reduction system, the Dolby NR button  should be pressed in. This reduces tape hiss.

When the radio is turned off by pressing the “OFF” side of the **ON OFF** button or by turning the key to steering lock position O, the cassette will automatically be ejected.

Tape equalization

For good reproduction quality it is necessary to adjust the tape player for the particular type of tape being used. Press the CR button **CR** in for cassettes using CrO₂ (chromium dioxide) tape. For all other types of tapes (i.e., ferric oxide, iron, etc.) the CR button **CR** should be out.

Care and maintenance

To avoid deterioration of the tone quality, clean the tape head with the special cleaning tape available through your authorized MERCEDES-BENZ dealer.

Radio anti-theft protection

Removal of the radio with the vehicle anti-theft alarm armed will render the radio inoperative indicated by a dashed line across the display.

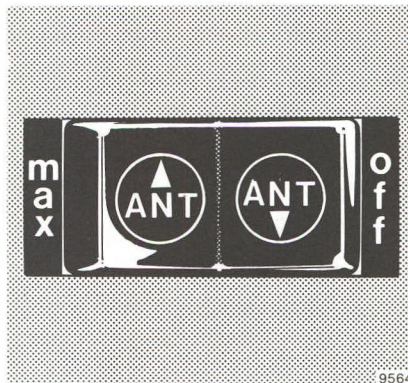

Automatic Antenna

The antenna switch can be actuated with the radio switched on and the key in steering lock positions 1 or 2.

- If the antenna switch is in the center position, the antenna extends automatically to medium height,

- if the antenna switch is engaged in the "max." position, the antenna extends fully,
- if the antenna switch is engaged in the "off" position, the antenna will not extend or will retract completely.

The height of the antenna can be adjusted to any intermediate position by actuating the antenna switch:

- If the antenna switch is in the center position, the antenna will extend to medium height. The antenna can be further extended or retracted to any height by rocking the switch (not engaging it).
- If the antenna is to be retracted, e.g. going through car wash, etc., engage switch in "off" position.

When the key is turned to steering lock position 0 or the radio is turned off, the antenna will retract completely.

Driving

Parking Brake	54
Starting and Shifting Gears	54
Manual Transmission	54
Recommended Shift Points for Manual Transmission	54
Automatic Transmission	55
Cruise Control	57
ABS-Brake System (Antilock Brake System)	58
Brake Pad Wear Indicator Lamp	59
Brake Warning Lamp	59
Charge Indicator Lamp	59
Oil Pressure Gauge	59
Low Engine Oil Level Indicator Lamp	59
Engine Oil Consumption	59
Coolant Temperature Gauge	60
Low Engine Coolant Level Indicator Lamp	60
Fuel Reserve Warning Lamp	60
Low Windshield Washer Level Indicator Lamp	60
Outside Temperature Indicator	60
Emission Control	61
Economical Driving Indicator (ECONOMY)	61
Traveling Abroad	61
Winter Driving	62
Tire Chains	62

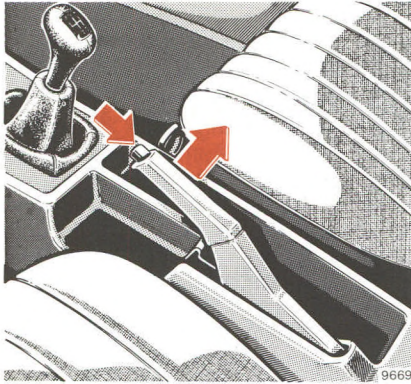

Parking Brake

To engage, pull up parking brake lever. The brake warning lamp in the instrument cluster should come on when the key is in steering lock position 2 (function check for brake warning lamp).

To release the parking brake, slightly pull up lever, push in lock button at the grip then lower it completely. The brake warning lamp in the instrument cluster should go out, when the lever is down.

Starting and Shifting Gears

Warning!

Keep driver's foot area clear at all times. Objects stored in this area may impair pedal movement.

Test the brakes shortly after driving off. Perform this procedure only when the road is clear of other traffic.

Warm up the engine smoothly. Do not place full load on the engine until the operating temperature has been reached.

When starting off on a slippery surface, do not allow one driving wheel to spin for an extended period.

Manual Transmission

See illustration for gearshift lever positions corresponding to the individual gears.

Stop the vehicle completely before shifting into reverse; to shift into reverse, press the shift lever down.

Do not exceed the maximum speed in the individual gears. See line markings on the speedometer.

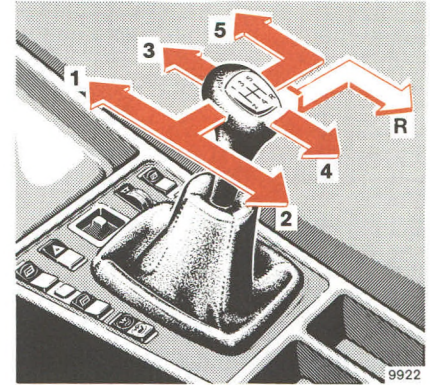

Note:

When vehicle is parked, be sure to engage first or reverse gear and set parking brake.

Recommended Shift Points for Manual Transmission

For good fuel economy, the following shift points are recommended:

Shift

from 1st to 2nd at 24 km/h (15 mph)
 from 2nd to 3rd at 40 km/h (25 mph)
 from 3rd to 4th at 64 km/h (40 mph)
 from 4th to 5th at 72 km/h (45 mph).

Automatic Transmission

The automatic transmission selects individual gears automatically, dependent upon selector lever position, vehicle speed and accelerator position.

Driving:

Shift selector lever to the desired driving position only when the engine is idling and the service brake is applied. Do not release the brake until ready to drive. The vehicle may otherwise start creeping when the selector lever is in a driving position.

Accelerator position

Partial throttle = early upshifting = normal acceleration

Full throttle = later upshifting = maximum acceleration

Depressing the accelerator beyond full throttle to kickdown position means downshifting to the next lower gear and thereby increasing acceleration. If you ease up on the accelerator after having attained the desired speed, the transmission will shift up again.

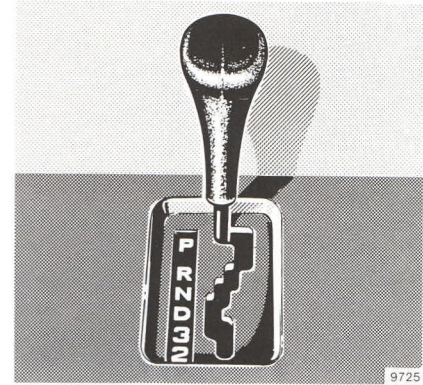

Selector lever positions

The automatic gear shifting process can be adapted to specific operating conditions using the selector lever.

“P” Parking lock.

The parking lock is an additional safeguard to the parking brake when parking the vehicle. Engage only with the car stopped.

“R” Reverse gear.

Shift to reverse gear only with the car stopped.

“N” Neutral.

No power is transmitted from the engine to the rear axle. When the brakes are released, the vehicle can be moved freely (pushed, towed or tow-started). Do not engage “N” when driving except when the vehicle is in danger of skidding (e.g. on icy roads, see page 17).

“D” Drive.

Automatic upshifting to top gear. Position “D” affords optimum driving characteristics under all normal operating conditions.

“3” Upshift to 3rd gear only. Suitable for medium range up or down-grades.

“2” Upshift to 2nd gear only. For driving in mountainous regions. Since transmission will not shift up further, this gear selection will make use of the engine’s braking power.

Important!

Do not exceed the engine speed limits for individual gear selections, which are indicated by marks on the speedometer.

Do not attempt downshifting to a lower gear (braking effect) unless the speedometer needle is below the speed-limit-mark of that particular gear range. Over-revving could result in damage to the engine.

On slippery road surfaces, it is not recommended to downshift in order to obtain braking action. This could result in rear wheel slip and reduced vehicle control.

Trailer operation

To prevent the engine from laboring at low RPMs, do not allow the engine speed to drop too low on uphill gradients. Depending on the degree of the incline, shift selector lever to positions “3” or “2” early enough to maintain engine RPMs within best torque range.

Stopping

For brief stops, e.g. at traffic lights, leave the transmission engaged and control vehicle with the service brake.

For longer stops with the engine idling, shift into “N” or “P”.

When stopping the car on a slope, do not hold it with the accelerator, use the brake. This avoids unnecessary transmission heat-up.

Maneuvering

To maneuver in tight areas, e.g. when pulling into a parking space, control the car speed by gradually releasing the service brake.

Accelerate gently and do not pump the accelerator. To rock a car out of soft ground (mud or snow), alternately shift from forward to reverse while applying partial throttle.

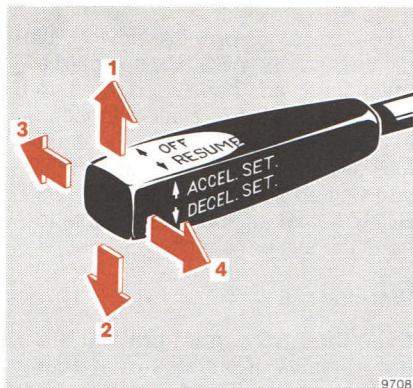

Cruise Control

Any given speed above approximately 40 km/h (25 mph) can be maintained with the cruise control by operating the lever.

- 1 Accelerate and set:
Lift lever briefly to set speed.
Hold lever up to accelerate.
- 2 Decelerate and set:
Depress lever briefly to set speed.
Hold lever down to decelerate.

Normally the vehicle is accelerated to the desired speed with the accelerator. Speed is set by briefly pushing the lever to position 1 or 2. The accelerator can be released.

The speed can be increased (e.g. for passing) by using the accelerator. As soon as the accelerator is released, the previously set speed will be resumed automatically.

If a set speed is to be increased or decreased slightly, e.g. to adapt to the traffic flow, hold lever in position 1 or 2 until the desired speed is reached. When the lever is released, the newly set speed remains.

- 3 Cancelling
To cancel the cruise control, briefly push lever to position 3. When you step on the brake or clutch pedal or the vehicle speed falls below approx. 40 km/h (25 mph), for example when driving upgrade, the cruise control will be cancelled.
- 4 Resume
If the lever is briefly pushed to position 4 when driving at a speed exceeding approximately 40 km/h (25 mph), the vehicle resumes the speed which was set prior to the cancellation of the cruise control. The last memorized speed is cancelled when the key in the steering lock is turned to position 1 or 0.

Note:

If the engine does not brake the vehicle sufficiently while driving on a downgrade, the speed you set on the cruise control may be exceeded and you may have to step on the brake pedal to slow down. As soon as the grade eases, the cruise controlled speed will again be maintained as long as the brakes were not previously applied.

Warning!

Only use the cruise control if the traffic and weather conditions make it advisable to travel at a steady speed.

Position "Resume" should be engaged only if the driver is fully aware of the previously set speed and wishes to resume this particular preset speed.

In the case of manual transmissions, the vehicle maximum speed in the individual gears should not be exceeded. See line markings on the speedometer. In the case of automatic transmissions, the transmission selector lever must not be shifted to position "N" when driving with the cruise control engaged as otherwise the engine will overrev.

ABS-Brake System (Antilock Brake System)

You can tell if your vehicle is equipped with an ABS by the yellow indicator lamp with the letters "ANTILOCK" in the instrument cluster (see page 13).

The ABS prevents the wheels from locking up above a speed of approx. 3 km/h (2 mph) independent of road surface conditions. It is necessary, however, that a speed of approx. 8 km/h (5 mph) has been exceeded at least once after start-up.

At the instant one of the wheels is about to lock up, you will feel a slight pulsation in the brake pedal and the vehicle, indicating that the ABS is in the regulating mode.

On slippery road surfaces, the ABS will already respond with a slight brake pedal pressure. The pulsating brake pedal can be an indication of hazardous road conditions, and remind you may want to take extra care driving.

The ABS indicator lamp in the instrument cluster comes on with the key in steering lock position 2 and should go out with the engine running.

If the charging voltage falls below 10 volts, the indicator lamp comes on and the ABS is switched off. When the voltage is above this value again, the indicator lamp should go out and the ABS will be operational.

If the ABS indicator lamp does not go out or comes on while driving, it indicates that the ABS has detected a malfunction and has switched off. In this case, the brake system functions in the usual manner, but without anti-lock assistance. We recommend that you visit an authorized MERCEDES-BENZ dealer as soon as possible to have the system checked.

Warning!

Even the ABS cannot prevent the natural laws of physics from acting on the vehicle. The ABS cannot prevent accidents, including those resulting from excessive speed in turns, following another vehicle too closely, or aquaplaning. Only a safe, attentive, and skillful driver can prevent accidents. The capabilities of an ABS equipped car must never be exploited in a reckless or dangerous manner which could jeopardize the user's safety or the safety of others.

Brake Pad Wear Indicator Lamp

The brake pad wear indicator lamp in the instrument cluster comes on when the key is turned to steering lock position 2 and it should go out when the engine is running. If the indicator lamp lights up during braking, this shows that the front wheel brake pads are worn.

Have the brake system checked at an authorized MERCEDES-BENZ dealer as soon as possible.

Brake Warning Lamp

The brake warning lamp will come on if insufficient brake fluid is in the reservoir (key in steering lock position 2 and parking brake released).

When the minimum mark on the reservoir is reached, have the brake system checked (brake lining thickness, leaks).

To test the brake warning lamp, pull up parking brake lever. Turn key to steering lock position 2 and the brake warning lamp should come on; release parking brake and the lamp should go out.

Charge Indicator Lamp

Should the charge indicator lamp fail to come on prior to starting when the key is in steering lock position 2 or should it fail to go out after starting or during operation, this indicates a fault which must be repaired at an authorized MERCEDES-BENZ dealer as soon as possible.

When the charge indicator lamp glows while the engine is running, the V-belt may have broken (which also makes the water pump inoperative). This may cause overheating and damage to the engine. In this case the V-belt must be replaced immediately.

Oil Pressure Gauge

The oil pressure at idle speed may drop to 0.3 bar (4.4 psi) if the engine is at operating temperature. This will not jeopardize its operational reliability. Pressure must, however, rise immediately upon acceleration.

Low Engine Oil Level Indicator Lamp

The indicator lamp comes on with the key in steering lock position 2 and should go out when the engine is running.

If it comes on with the engine running and at operating temperature, the oil level has dropped to the minimum mark on the dipstick. When this occurs, the indicator lamp will first come on intermittently and then stay on if the oil level drops further. Engine oil should be added at the next opportunity (we recommend that you add 1 liter [1.1 US qt]).

In addition to the indicator lamp, the engine oil level should be periodically checked with the dipstick, for example after a fuel stop, or before a long trip (see page 66).

Engine Oil Consumption

Engine oil consumption can only be determined after a certain mileage has been covered. During the break-in period, higher oil consumption may be noticed and is normal.

Coolant Temperature Gauge

If the antifreeze mixture is effective to -30°C (-22°F), the boiling point of the coolant in the pressurized cooling system of your vehicle is approx. 125°C (257°F) (see also “Fuels, Coolants, Lubricants, etc.”).

During severe operating conditions and stop-and-go city traffic, the coolant temperature may rise close to the red marking.

Low Engine Coolant Level Indicator Lamp

The indicator lamp comes on with the key in steering lock position 2, and should go out when the engine is running.

If it comes on with the engine running, the coolant has dropped below the required level. You should then have the engine cooling system checked for signs of leakage and have it refilled as soon as possible (see page 65).

Fuel Reserve Warning Lamp

The fuel reserve warning lamp should come on when the key is turned to steering lock position 2, and should go out after the engine is running.

If the warning lamp stays on after the engine starts, or comes on while driving, it indicates that the fuel level is down to the reserve quantity of 7.0 l (1.8 US gal).

Low Windshield Washer Level Indicator Lamp

The indicator lamp comes on with the key in steering lock position 2 and should go out when the engine is running.

If it comes on with the engine running, the level of the reservoir has dropped to about $1/4$ of the total volume and should be filled again with washer fluid to which about 3 capfuls of MB auto-shampoo have been added.

Outside Temperature Indicator

The temperature sensor is attached to the front bumper behind the license plate base plate. Due to its location, the sensor can be affected by road or engine heat during idling or slow driving. This means that the accuracy of the displayed temperature can only be verified by comparison to a thermometer located next to the sensor, not by comparison to external displays (i.e., bank signs, etc.).

Emission Control

Certain systems of the engine serve to keep the toxic components of the exhaust gases within permissible limits required by law.

These systems, of course, will function properly only when maintained strictly according to factory specifications. Any adjustments on the engine should, therefore, be carried out only by qualified MERCEDES-BENZ technicians. The adjustments of the engine should not be altered in any way. Moreover, the specified service and maintenance jobs must be carried out regularly according to MERCEDES-BENZ servicing requirements. For details refer to the Maintenance Booklet.

Warning!

Inhalation of exhaust gas is hazardous to your health. All exhaust gas contains carbon monoxide, and inhaling it can cause unconsciousness and lead to death.

Do not run the engine in confined areas (such as a garage) which are not properly ventilated. If you think exhaust gas fumes are entering the vehicle while driving, have the cause determined and corrected immediately. If you must drive under these conditions, drive only with at least one window fully open.

Economical Driving Indicator (ECONOMY)

The indicator shows the fuel consumption tendency during various driving modes.

High fuel consumption is indicated if the pointer moves into the red area; economical driving is indicated when it is in the black area. The indications should only be compared within the same gear.

Do not compare fuel consumption readings between different gears. The following rule applies: If you drive at equal speeds, the fuel consumption is lower in the higher gear, although in this gear the pointer is more frequently in the red area.

Traveling Abroad

Abroad, there is a widely-spread MERCEDES-BENZ service network at your disposal. If you travel into areas which are not listed in the index of your dealer directory, you should request pertinent information from your dealer.

Winter Driving

Have your car winterized at an authorized MERCEDES-BENZ dealer before the onset of winter.

- Engine oil change: If “year-round” multigrade engine oil is not used, be sure to use an SAE grade based on ambient temperature. For recommended engine oil viscosities refer to “Fuels, Coolants, Lubricants, etc.” and last page.
- Anticorrosion/antifreeze in the coolant: Check anticorrosion/antifreeze protection periodically. For capacity refer to “Fuels, Coolants, Lubricants, etc.”.

- Additive in the windshield washer system: Add windshield washer solvent to the water.
- Test battery: Battery capacity drops with decreasing ambient temperature. A well charged battery ensures that the engine can always be started, even at low ambient temperatures.
- Tires: We recommend M + S radial tires on all four wheels for the winter season. Observe permissible maximum speed for M + S radial tires and the legal speed limit.

Tire Chains

Use only tire chains that are tested and recommended by us. Any authorized MERCEDES-BENZ dealer will be glad to advise you on this subject.

Chains should only be used on the rear wheels. Adhere to the manufacturer’s mounting instructions.

After driving a short distance retighten the mounted chains.

Tire chains should only be driven on snow at speeds not to exceed 50 km/h (30 mph). Remove chains as soon as possible when driving on roads without snow.

For tips on driving on slippery winter roads refer to page 17.

Practical Hints

Hood	64
Checking Coolant Level	65
Adding Coolant	65
Engine Oil Level Check	66
Fluid Level –	
Automatic Transmission	67
First Aid Kit	68
Stowing things in the Vehicle	68
Spare Wheel, Jack,	
Vehicle Tool Kit	68
Wheels, Tires	69
Changing Wheels	70
Tire Inflation Pressure	71
Headlamp Adjustment	72
Replacing Bulbs	72
Unlocking of Fuel Filler Flap	75
Fuses	76
Spark Plugs	76
Battery	77
Tow-starting and Towing	
the Vehicle	78
Emergency Operation of	
Sliding Roof	79
Jump Starting	80
Cleaning and Care of the Vehicle	81
Head Restraints	84
Rear Seat Cushion	85
Ash tray	85
Roof Rack	86
Spare Parts Service	86
Layout of Poly V-belt Drive	86

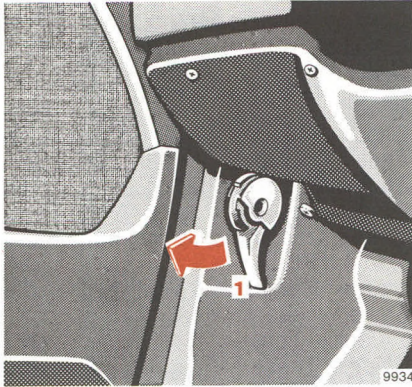

Hood

To open:

To unlock the hood, pull release lever (1) under the driver's side of the instrument panel. At the same time handle (2) will pop out of the radiator grille (it may be necessary to lift the hood up slightly).

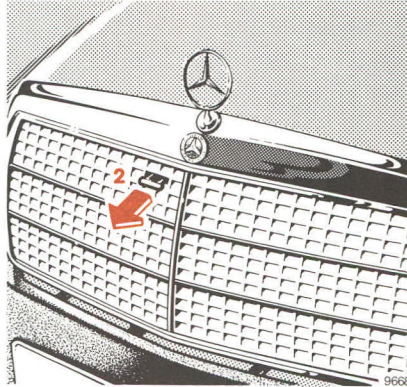

Pull handle (2) completely out of radiator grille and open hood (do not pull up on handle).

Caution!

To avoid damage to the windshield wiper or hood, open the hood only with wiper in the parked position.

To close:

Push hood down on left side (viewed in driving direction).

Warning!

To help prevent personal injury, stay clear of moving parts when the hood is open and the engine is running. Be sure the hood is properly closed before driving.

The engine is equipped with a transistorized ignition system. Because of the high voltage it is dangerous to touch any components (ignition coil, distributor, spark plug sockets, ignition cables, diagnostic socket) of the ignition system

- if the ignition is "on" and the engine revved manually
- while starting the engine
- with the engine running.

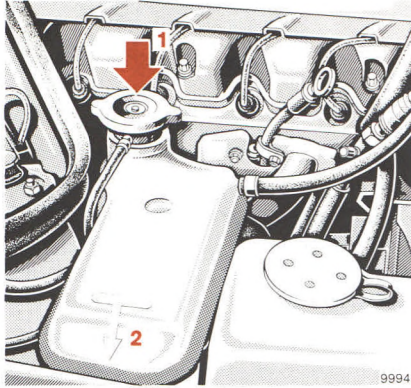

- 1 Coolant reservoir cap
- 2 Marking for coolant level

Checking Coolant Level

The coolant level can be checked visually at the transparent coolant reservoir.

To check the coolant level, the vehicle must be parked on level ground.

The coolant level must reach:

The marking (2, arrow) on the reservoir when the engine is cold.

Approx. 1 cm (0.4 in) higher when the engine is at operating temperature.

Adding Coolant

If coolant has to be added, a 50/50 mixture of water and MB anticorrosion/antifreeze should be used.

Warning!

- **Do not open the engine hood if you see or hear steam or coolant escaping from the engine compartment. With the engine idling and the climate control system switched off, wait until no steam or coolant can be seen before opening the hood.**
- **Do not remove pressure cap on coolant reservoir if engine temperature is above 90° C (194° F). Allow engine to cool down before removing cap. The coolant reservoir contains hot water and is under pressure.**
- **Using a rag, turn cap to first notch to relieve excess pressure. If opened immediately, hot scalding fluid and steam will be blown out under pressure.**

The drain plugs for the cooling system are located on the right-hand side of the engine block and the bottom of the radiator.

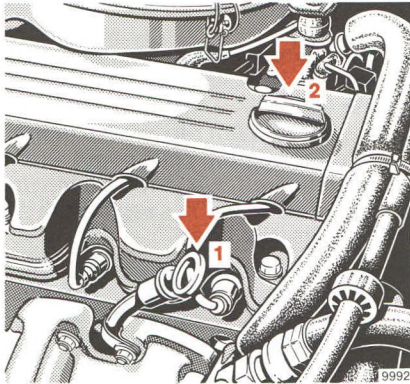

- 1 Oil dipstick
- 2 Oil filler cap

Engine Oil Level Check

The best time to check the engine oil level is when the oil is warm, such as during a fuel stop. With the vehicle on level ground, stop the engine and wait a few minutes for the oil to drain back to the oil pan.

Wipe the dipstick clean before checking.



Add oil, if needed, only to the upper mark (max.). Do not overfill the engine.

For viscosity and capacity, see “Fuels, Coolants, Lubricants, etc.” and last page.

For low engine oil level indicator lamp, see page 59.

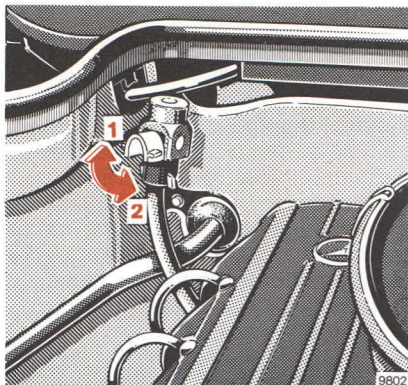

Fluid Level – Automatic Transmission

Check the fluid level in the automatic transmission regularly and prior to an extended trip.

Check transmission fluid level with the engine idling, parking brake engaged and selector lever in position “P”. The vehicle must be parked on level ground. Prior to the check, allow engine to idle for approx. 1 to 2 minutes.

Measure fluid level with the dipstick completely inserted and the locking lever released (1).

Extreme cleanliness must be observed! To wipe the dipstick, use a clean, lintfree cloth. To fill the transmission with fluid, pour it through a fine-mesh filter into the dipstick opening. Even the slightest impurity may cause operational troubles.

The fluid level in the transmission is dependent upon its temperature. The maximum and minimum fluid level marks on the dipstick are applicable references only if the transmission fluid has reached its normal operating temperature of 80°C (176°F).

Important!

If the transmission fluid cools down to 20–30°C (68–86°F), which is the normal shop temperature range, then the maximum fluid level will be approximately 10 mm (0.4 in) below the minimum mark on the dipstick. We stress this point because a fluid change is normally performed when the transmission fluid has cooled down to shop temperature.

The fluid level must not exceed the dipstick maximum mark with the fluid at operating temperature. Drain or siphon off excess fluid, if required.

Then push dipstick all the way in and swing locking lever downwards (2).

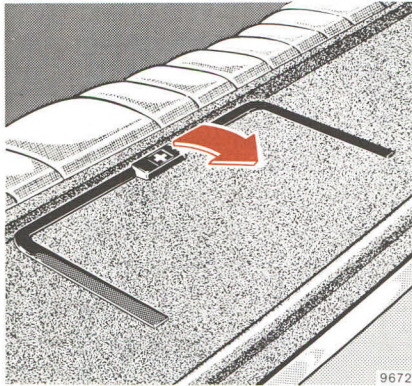

First Aid Kit

The first aid kit is stored in the shelf below the rear window.

Stowing Things in the Vehicle

Warning!

To help avoid personal injury during a collision or sudden maneuver, exercise care when stowing things. Put luggage or cargo in the trunk if possible. Do not pile luggage or cargo higher than the seat backs. Do not place anything on the shelf below the rear window.

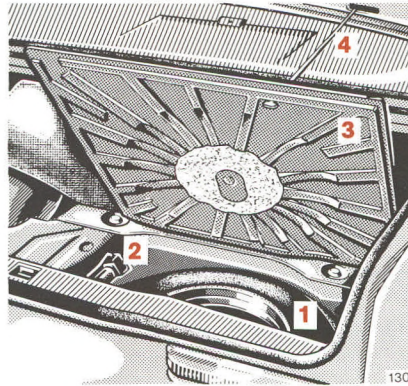

Spare Wheel, Jack, Vehicle Tool Kit

The spare wheel (1), jack (2) and tool kit are stored in a compartment below the hinged trunk floor (3).

Lift up trunk floor and engage strap (4) in trunk lid.

The hinged door can also be removed completely by raising the door to approximately 45°, lifting it slightly at the hinged side and pulling it out to the rear.

Warning!

The jack is designed exclusively for jacking up the vehicle at the jack tubes built into either side of the vehicle. Use the jack only to lift the vehicle during a tire change. Never get beneath the vehicle while it is supported only by the jack. Jack stands must be used when working under the vehicle. Always set parking brake before raising vehicle with the jack. For details, refer to "Changing Wheels".

Wheels, Tires

Replace wheels or tires with the same designation, manufacturer and type as shown on the original part.

Warning!

Do not mix different tire construction types (i.e. radial, bias, and biasbelted) on your car because handling may be adversely affected and may result in loss of control.

See any authorized MERCEDES-BENZ dealer for information on tested and recommended wheels and tires for summer and winter operation. They can also offer more advice concerning tire service and purchase.

Front tires should be replaced in sets. If possible, the spare tire should be used on the rear wheels. We recommend that you break in new tires for approx. 100 km (60 miles) at moderate speed.

It is imperative that the wheel mounting bolts be retightened after approx. 800 km (500 miles).

On new vehicles retightening is carried out in the course of the 1st inspection. Retightening is also necessary when new wheels are fitted at a later date, e.g. when the spare wheels is used for the first time or when a new set of wheels with M + S tires are installed.

Tightening torque: 110 Nm (80 lb-ft).

For tire specifications, refer to "Technical Data".

Rotating wheels:

The wheels can be rotated according to the degree of tire wear while retaining the same sense of rotation. Rotating, however, should be carried out before the characteristic tire wear pattern (shoulder wear on front wheels and tread center wear on rear wheels) becomes visible at a mileage of 5000–10 000 km (3000–6000 miles) as otherwise the driving properties deteriorate.

Underinflated tires due to a slow leak (e.g. due to a nail in the tire) may cause damage such as tread separation, bulging, etc. Regular tire pressure checks (including the spare tire) at intervals of no more than 14 days are therefore essential. Keep in mind that warm tires have a higher pressure than cold tires. (See tire pressure chart on fuel filler door and the last page). If a tire constantly loses air, it should be inspected for damage.

Use only genuine MERCEDES-BENZ wheel bolts (identified by Mercedes-Star on bolt shaft).

Thoroughly clean the inner side of the wheels any time you rotate the wheels or wash vehicle underside.

Dented or bent rims cause tire pressure loss and damage to the tire beads. For this reason, check rims for damage at regular intervals.

The rim flanges must be checked for wear before a tire is mounted. Remove burrs, if there are any.

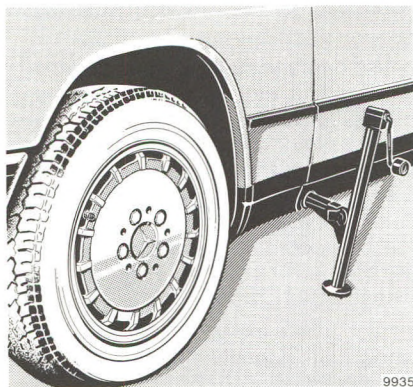

Changing Wheels

1. Set parking brake.
2. With manual transmission, shift gear shift lever to 1st or reverse gears respectively, with automatic transmission, move selector lever to position "P".
3. Prevent vehicle from rolling away by blocking wheels with wheel chocks: When changing a wheel on a hill, place chocks on the downhill side of each wheel of the other axle; on a level road, place one chock in front of and one behind the wheel that is diagonally opposite to the wheel being changed.

4. Using the combination wrench, loosen but do not yet remove the wheel bolts.
5. Remove protective cap from the jack support tube. (The tube openings are located directly behind the front wheel housings and in front of the rear wheel housings.)
6. Insert jack arm fully into the tube hole up to the stop. Position the jack so that it will always be vertical as seen from the side, even on inclines. Jack up the vehicle until the wheel is clear off the ground.

Warning!

The jack is designed exclusively for jacking up the vehicle at the jack tubes built into either side of the vehicle. Use the jack only to lift the vehicle during a tire change. Never get beneath the vehicle while it is supported only by the jack. Jack stands must be used when working under the vehicle.

7. Then unscrew wheel bolts completely. Keep bolt threads protected from dirt and sand. While removing last bolt, hold wheel against hub to avoid paint damage on rim.

8. Remove wheel.
9. Screw the alignment bolt (supplied in tool kit) into an upper threaded hole.
10. Adjust the jack height so that the wheel can be slipped on without being lifted.
11. Install spare wheel on wheel hub. Insert wheel bolts and tighten them slightly. To avoid paint damage, place wheel flat against hub and hold it there while installing first wheel bolt. Unscrew the alignment bolt to install the last wheel bolt.
12. Lower car, remove jack and place cap into the jack support tube. Tighten the five bolts evenly, always skipping one, until all bolts are tight. Observe a tightening torque of 110 Nm (80 lb-ft).
13. Correct tire pressure.

Important!

Retighten wheel mounting bolts after approx. 800 km (500 miles). Observe a tightening torque of 110 Nm (80 lb-ft).

Tire Inflation Pressure

A table (see fuel filler flap or last page) lists the tire inflation pressures specified for summer and winter tires as well as for the varying operating conditions.

Important!

Tire pressure differs by approx. 0.1 bar (1.5 psi) per 10°C (18°F) of air temperature change. Keep this in mind when checking tire pressure inside a garage – especially in the winter.

Example:

If garage temperature = approx. + 20° C (+ 68° F)
and,
ambient temperature = approx. 0° C (+ 32° F)
then the adjusted air pressure = specified air pressure + 0.2 bar (+ 3 psi).

Tire pressures listed for light loads are minimum values offering high driving comfort. Increased inflation pressures for heavy loads produce favorable handling characteristics with lighter loads and are perfectly permissible. The ride of the vehicle, however, will become somewhat harder.

Tire temperature and pressure increase with the vehicle speed. Tire pressure should therefore only be corrected on cold tires. Correct tire pressure in warm tires only if pressure has dropped below the pressure listed in the table and the respective operating conditions are taken into consideration.

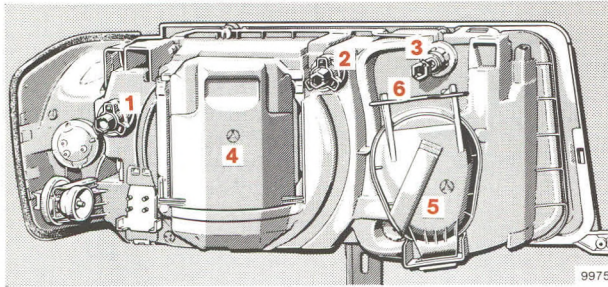

Headlamp Adjustment

Correct headlamp adjustment is extremely important. Check and readjust headlamps at regular intervals and when a lamp has been replaced.

Replacing Bulbs

Only handle new bulbs for headlamps and taillamps with tissue paper or similar.

Install only 12 volt bulb with the specified watt rating.

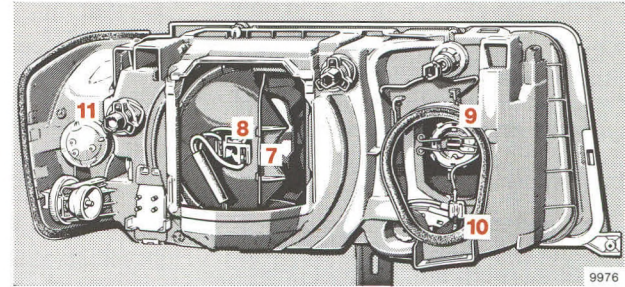

Headlamp Assembly

- | | |
|--|---|
| <ol style="list-style-type: none"> 1 Headlamp horizontal adjusting screw 2 Headlamp vertical adjusting screw 3 Fog lamp adjusting screw 4 Headlamp cover 5 Fog lamp cover | <ol style="list-style-type: none"> 6 Fog lamp cover clamp 7 Headlamp cover clamp 8 Headlamp electrical connector 9 Fog lamp bulb 10 Fog lamp electrical connector 11 Turn signal, parking, side marker and standing lamp bulb |
|--|---|

Replacing bulbs:

Bulb for turn signal, parking, side marker and standing lamp (21/5W/32/3 cp):

Turn bulb socket (11) with lamp bulb to the left and pull out socket.

Push lamp bulb into socket and turn to the left and pull out bulb.

Sealed Beam/Halogen headlamp:

Pull cover (4) up to release it from bracket.

Disconnect plug (8) and disengage clamp (7).

Take out sealed beam together with retaining frame towards the front. Press off frame from sealed beam.

Fog lamp bulb (H3):

Disengage clamp (6) and remove cover (5). Disconnect plug (10), disengage retaining clip and remove bulb (9).

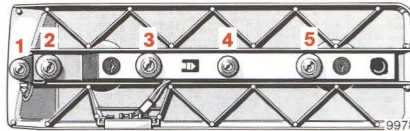
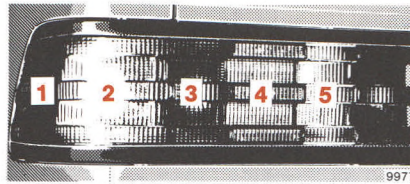

Taillamp Assemblies

- 1 Side marker lamp (10 W/6 cp)
- 2 Turn signal lamp (21 W/32 cp)
- 3 Stop lamp (21 W/32 cp)
- 4 Tail, parking and standing lamp (10 W/6 cp)
- 5 Backup lamp (21 W/32 cp)

Turn both locks in the trunk to the left as far as the stop and detach lamp bracket. To replace the bulbs, depress, turn to the left and remove.

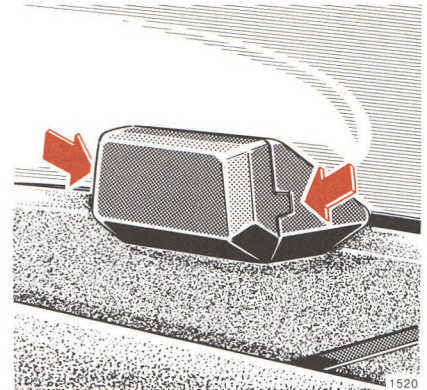

High Mounted Stop Lamp (21 W/32 cp)

To replace the bulb, pull tabs on both sides (arrows) – using a screwdriver – to release cover.

Press bulb down, turn counterclockwise and remove.

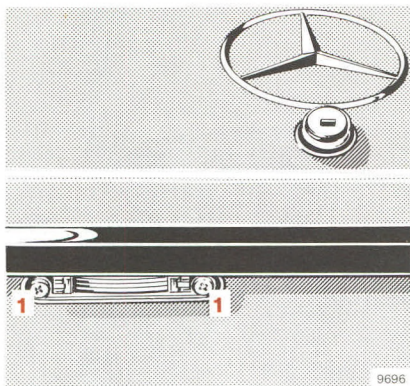

License Plate Lamps (5 W lamp)

Loosen both the securing screws
(1) and take out lamp.

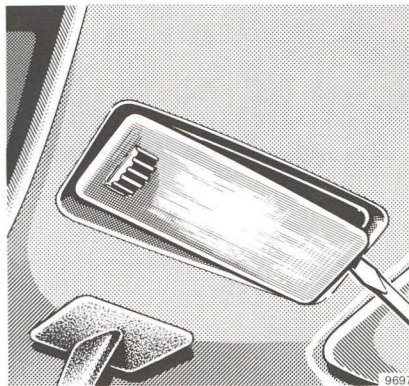

Interior Lamps (10 W lamp)

To replace the bulb, lift off front lamp at
RH side, pull it out and open reflector.
The same applies to the removal of the
rear lamp.

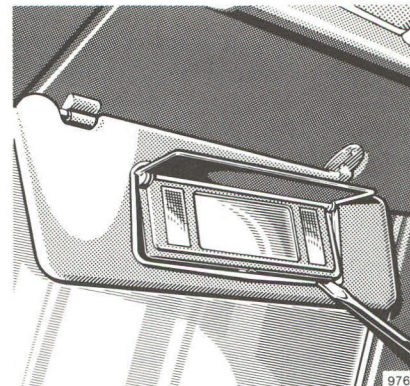

Sun Visor Lamps (5 W lamp)

To replace a bulb, pry off the cover by
inserting a screwdriver in the left and
right slots located on the lower edge.
To reinstall the mirror assembly, the
cover must be closed.

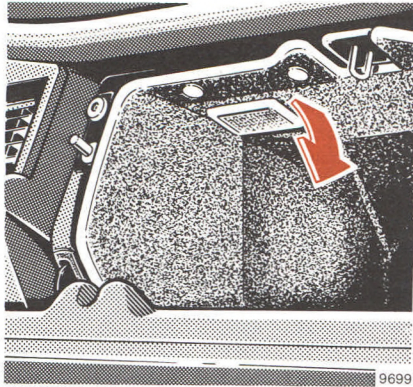

Glove Compartment Lamp
(5 W lamp)

To replace pull down cover and re-
move bulb.

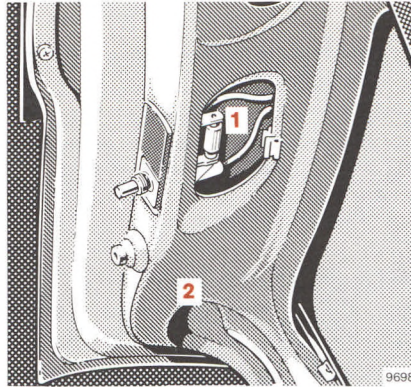

Trunk Lamp
(10 W lamp)

The bulb (1) is easily accessible when
the trunk lid (2) is opened.

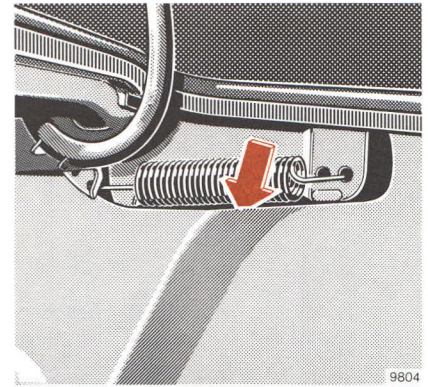

Unlocking of Fuel Filler Flap

If the central locking system does not
release the fuel filler flap automatically,
pull down right trunk panel slightly and
pull back the knob on the vacuum
element while opening the filler flap.

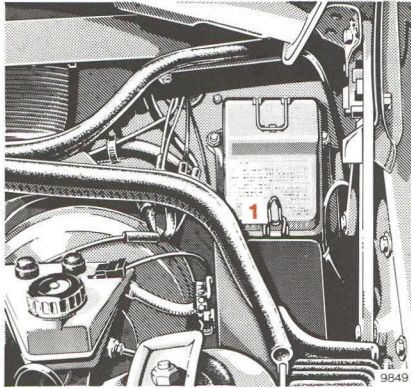

Fuses

The fuse box is located in the engine compartment.

All fuse protected equipped is listed by number and letter on a label in the lid of the fuse box. The numbers and letters above the fuses correspond to the ones on the label.

To exchange a fuse, remove clamp (1) and remove fuse box cover.

Before replacing a blown fuse, determine the cause of the short circuit.

Spare fuses are furnished inside the fuse box. Observe amperage and color of fuse.

Always use a new fuse for replacement. Never attempt to fix or bridge a blown fuse.

After replacing a fuse, replace fuse box cover and secure with clamp (1).

Spark Plugs

This vehicle is equipped with spark plugs as required for driving in the USA. Should additional information be necessary, your MERCEDES-BENZ dealer will be happy to offer advice.

Remove and install spark plugs (provided with sealing cone) only with combination wrench from the vehicle tools or with a recommended spark plug wrench. Tightening torque 10–20 Nm (7–15 lb-ft).

Battery

Check electrolyte level in each cell approximately every 4 weeks, and more frequently during the summer and in hot climates.

Refill battery with distilled or tap water. Do not use metal funnels or push through the overflow-protection diaphragms in the filler holes.

The battery is completely filled when the water stops draining through the overflow-protection diaphragm.

To check the battery charge with a hydrometer, push its tip through the overflow-protection diaphragm and take the electrolyte sample.

Coat battery terminal clamps with acidproof grease. Keep battery clean and dry.

The service life of the battery is also dependent on its condition of charge. It must always be sufficiently charged for the battery to last an optimum length of time.

Therefore, we recommend that you have the battery charge checked frequently if you use the vehicle mostly for short distance trips, or if it is not used for long periods of time.

Only charge a battery with a battery charger after it has been disconnected from the vehicle electrical circuit.

Warning!

Battery fluid contains sulfuric acid. Do not allow this fluid to come in contact with eyes, skin, or clothing.

In case it does, immediately flush affected area with water and seek medical help.

A battery will also produce hydrogen gas, which is flammable and explosive. Keep flames or sparks away from battery, i.e. improper connection of jumper cables, cigarette smoking, etc..

While the engine is running the battery terminal clamps must not be loosened or detached as otherwise the alternator and other electronic units would be damaged.

Only tow vehicle with the battery connected.

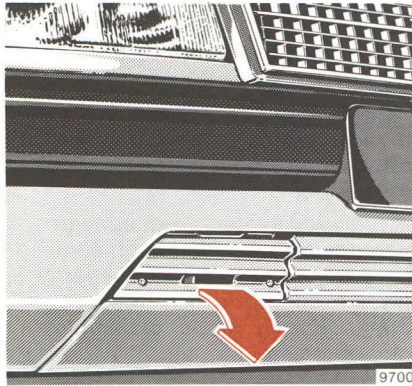

Tow-starting and Towing the Vehicle

The rear towing eye is welded from below to the right side of the spare tire compartment. The front towing eye is located behind the flap in the front bumper panel (arrow).

Flap removal: Insert finger in the opening of the flap, pull the flap out slightly and downward to remove.

To install the flap, engage the flap at the top and press in the bottom securely.

Engage hook of towing bar from the right side of the towing eye. This will ensure adequate clearance between the towing bar and the bumper panel opening during turns.

Only tow-start vehicle with the battery cables connected and the key in steering lock position 2.

Warning!

When the engine is not running, both the service brake and the steering are without power assistance. Under these circumstances, a much greater effort is necessary to steer or stop the vehicle.

Tow-starting a Vehicle with Automatic Transmission

Shift selector lever to position “N”. Turn key to steering lock position 2 and have vehicle towed.

After attaining a towing speed of 30 km/h (18 mph) (with cold transmission) or 50 km/h (30 mph) (with warm transmission), shift selector lever to position “2” to tow-start the engine. Only touch the accelerator when the engine is turning. As soon as the engine has started, quickly return selector lever to “N”.

If the engine fails to fire within a few seconds, return the selector lever from “2” to “N” as otherwise the transmission may be damaged.

For another starting attempt, tow car again for a short while with the selector lever in position “N” and then repeat starting procedure.

The same procedure may be used for starting the engine while rolling downhill.

Towing a Vehicle with Automatic/Manual Transmission

The vehicle may be towed with all of the wheels on the ground and the selector lever in position "N"/neutral for distances up to 120 km (75 miles) and at a speed not to exceed 50 km/h (30 mph).

To positively avoid a possibility of damage to the transmission, however, we recommend to disconnect the drive shaft at the rear axle drive flange on any towing beyond a short tow to a nearby garage.

Front towing: Attach J-hooks to lower control arms. Position a 4 ft long, 4 in × 4 in piece of wood with spacer blocks under tie-down hooks. Attach safety chains to tie-down hooks.

Rear towing: Attach T-hooks to tie-down slots in frame (behind spring seat). Attach safety chains to lower spring links.

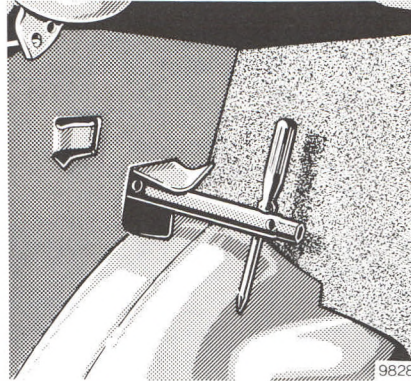

Emergency Operation of Sliding Roof

The sliding roof can be opened or closed manually should an electrical malfunction occur.

Remove small access plug in left side-panel of trunk. Insert socket wrench (from tool kit) through opening in panel and place on the hex-drive of the electric motor. Turn socket wrench (by hand) to open or close roof as desired. Turning socket clockwise closes roof.

Jump Starting

If the battery is discharged the engine can be started with jumper cables and the (12 V) battery of another vehicle. Proceed as follows:

1. Position the vehicle with the charged battery so that the jumper cables will reach, but never let the vehicles touch. Make sure the jumper cables do not have loose or missing insulation.
2. On both vehicles:
 - Turn off engine and all lights and accessories, except hazard flashers or work lights.
 - Apply parking brake and shift selector lever to position “P” (neutral for manual transmission).
 - Be sure the vent caps are tight and level. Place a damp cloth over the vent caps, making certain it is clear of all moving parts.
3. Clamp one end of the first jumper cable to the positive (+) terminal on the discharged battery and the other end to the positive (+) terminal on the charged battery. Make sure the cable clamps do not touch any other metal parts.
4. Clamp one end of the second jumper cable to the grounded negative (–) terminal of the charged battery and the final connection to a grounded heavy metal bracket in the engine compartment or on the engine of the disabled vehicle. Make sure the cables are not on or near pulleys, fans, or other parts that will move when the engine is started.
5. Start engine of the vehicle with the charged battery and run at high idle. Then start engine of the disabled vehicle in the usual manner.
6. After the engine has started, remove jumper cables by reversing the above installation sequence exactly, starting with the jumper cable connected to a heavy metal bracket in the disabled vehicle’s engine compartment. When removing each clamp, make sure that it does not touch any other metal while the other end is still attached.

Important:

A discharged battery can freeze at approx. -10°C ($+ 14^{\circ}\text{F}$). In all cases it must be thawed out before jumper cables are used.

Jumper cable specifications:

- Minimum cable cross-section of 25 mm^2 or approx. 2 AWG
- Maximum length of 3500 mm (11.5 ft).

Warning!

Never lean over batteries while jump starting, you might get burned.

Battery fluid contains sulfuric acid. Do not allow this fluid to come in contact with eyes, skin, or clothing. In case it does, immediately flush affected area with water, and seek medical help.

A battery will also produce hydrogen gas, which is flammable and explosive. Keep flames or sparks away from battery, i.e. improper connection of jumper cables, cigarette smoking, etc..

Cleaning and Care of the Vehicle

In operation, your vehicle is subjected to varying external influences which, if gone unchecked, can attack the paint-work as well as the underbody and cause lasting damage.

Such damage is caused not only by extreme and varying climatic conditions, but also by air pollution, road salt, tar, gravel and stone chipping. Grease and oil, fuel, coolant, brake fluid, bird droppings, tree resins, etc. should be removed immediately to avoid paint damage. Frequent washing, however, reduces and/or eliminates the aggressiveness and potency of the above adverse influences.

More frequent washings are necessary to deal with unfavorable conditions; for example, near the ocean, in industrial areas (smoke, exhaust emissions), or during winter operation.

You should check your vehicle from time to time for stone chipping or other damage. Any damage should be repaired as soon as possible to prevent the start of corrosion.

In doing so, do not neglect the underside of the car. A prerequisite for a thorough check is a washing of the underbody followed by a thorough inspection. Damaged areas need to be re-undercoated.

Your vehicle has been treated at the factory with a wax-base rustproofing in the body cavities which will last for the lifetime of the vehicle. Post-production treatment is neither necessary nor recommended by MERCEDES-BENZ because of the possibility of incompatibility between materials used in the production process and others applied later.

After every engine cleaning you should have the engine compartment re-rustproofed with MB anticorrosion-wax. Before rustproofing, all control

linkage bushings have to be lubricated with hydraulic oil (check with your local MERCEDES-BENZ dealership for recommended brands).

We have selected car-care products and compiled recommendations which are specially matched to our vehicles and which always reflect the latest technology. You can obtain MB car-care products at every MERCEDES-BENZ dealer.

Scratches, corrosive deposits, corrosion or damage due to negligent or incorrect care cannot always be removed with the car-care products recommended here. In such cases it is best to seek aid at your authorized MERCEDES-BENZ dealer.

The following topics deal with the cleaning and care of your vehicle and give important "how-to" information as well as references to recommended MB car-care products.

Car Washing

Before washing your vehicle, remove insect residues. MB insect remover is recommended. Do not use hot water or wash your car in direct sunlight. Use only a mild car wash detergent, such as MB auto shampoo.

Thoroughly spray the car with a diffused jet of water. Direct only a very weak spray towards the ventilation intake. Use plenty of water and rinse the sponge and chamois frequently.

Rinse with clear water and thoroughly wipe dry with a chamois. Do not allow cleaning agents to dry on the finish.

If the vehicle has been run through an automatic car wash – in particular one of the older installations – rewipe the recessed sections in the taillamps (for improved prevention of soiling) if necessary. No solvents (fuels, thinners etc.) must be used.

In the winter, thoroughly remove all traces of road salt as soon as possible.

When washing the underbody, do not forget to clean the inner sides of the wheels.

Tar Stains

Quickly remove tar stains before they dry and become more difficult to remove. MB tar remover is recommended.

Window Cleaning, Wiper Blade

Use a window cleaning solution on very dirty or oil-stained windows. Clean the wiper blade rubber with a clean cloth and detergent solution.

Replace blade at least once or twice a year.

To assist with the removal of accumulated road film on the windshield and improve wiping ability, a cap of MB auto shampoo can be added to the 3 liter container of washer solvent.

Plastic Parts, Headliner and Rubber Parts

Do not use oil or wax on these parts.

Seat Belts

The webbing must not be treated with chemical cleaning agents. Use only clear, lukewarm water and soap. Do not dry the webbing at temperatures above 80°C (176°F) or in direct sunlight. Never bleach or re-dye the webbing as this may severely weaken the belts.

Steering Wheel, Gear Shift Lever and Instrument Cluster

Use a gentle dish-washing detergent or mild detergent for delicate fabrics as a washing solution. Wipe with a cloth moistened in lukewarm solution. Do not use scouring agents.

Upholstery

MB Tex: Wipe upholstery with a damp cloth and dry thoroughly.

Leather: Wipe leather upholstery with a damp cloth and dry thoroughly or clean with MB leather care. Exercise particular care when cleaning perforated leather as its underside should not become wet.

Velours: Pressure marks resulting from dampness and heat may appear to be stains. Such marks can be removed by wiping with a moistened brush, ironing with a wet cloth or by treating with a dry shampoo. Do not sit on damp upholstery. Quick drying is achieved by applying hot air – for example, by using a hair dryer. If in doubt, please consult your MERCEDES-BENZ dealer.

Using aftermarket seat covers or wearing clothing that have the tendency to give off coloring (e.g. when wet, etc.) may cause the upholstery (velour for example) to become permanently discolored. By lining the seats with a proper intermediate cover, contact-discoloration will be prevented.

Paintwork, Painted Body Components

MB-Gloss Preserver should be applied when water drops on the paint surface do not “bead up”; normally in 3–5 months depending on climate and washing detergent used.

MB-Polish should be applied if paint surface shows signs of dirt embedding (i.e. loss of gloss).

MB-Fine Polishing Paste must be used when the paint surface shows signs of excessive fading/chalking due to lack of care, etc..

Do not apply any of these products or wax if your car is parked in the sun or if the hood is still hot. Use the appropriate MB Touch-Up Stick for quick and provisional repairs of minor paint damage (i.e. chips from stones, car doors, etc.).

Light Alloy Wheels

If possible, clean wheels once a week with MB alloy wheel cleaner and sealer. Use an ample supply of water.

Ornamental Moldings (Chrome-Plated, Aluminium)

For regular cleaning and care of very dirty chrome-plated parts, use a chrome cleaner.



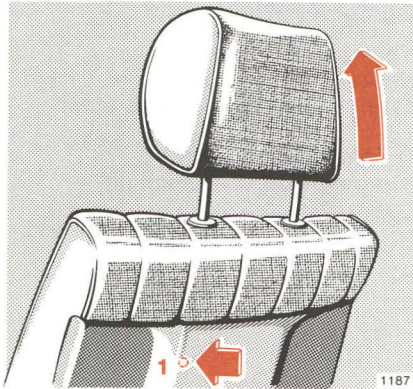

Head Restraints

Removing front seat head restraints:

Move the manually adjustable head restraint slightly forward and pull up to the stop.

Bring the power adjustable head restraint to its highest position.

Depress release button (1) to be felt under the seatback covering material and pull head restraint up sharply, holding it by the left head restraint post (viewed in driving direction). Then pull out head restraint completely with both hands.

The release button (1) is located below the left head restraint post on both front seats.

Installing front seat head restraints:

Insert the head restraint and push it down.

With power head restraint it may be necessary to first push up adjustment switch for 5 seconds.

Adjust head restraint to the desired position.

Removing rear seat head restraints:

Pull head restraint up until detent is felt. Then pull it out sharply using both hands.

Installing rear seat head restraints:

Insert the head restraint and push it down.

Adjust head restraint to the desired position.

Warning!

For your protection, drive only with properly positioned head restraints.

Do not drive the vehicle without the front seat head restraints. Head restraints are intended to help reduce injuries during an accident.

For positioning of head restraints refer to pages 30 and 31.

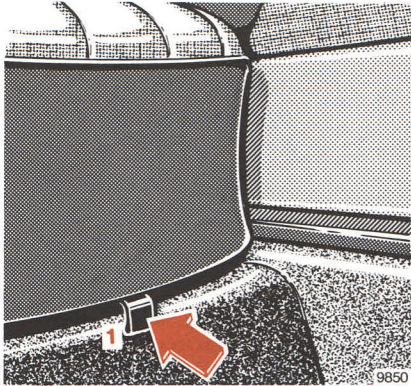

Rear Seat Cushion

Removal: Push down locking tabs 1 (left and right) and pull up the front of the seat cushion.

Installation: Slide rear edge of cushion under the backrest so that both wire loops under the backrest engage at the seat cushion. Push front of cushion down until it locks in place.

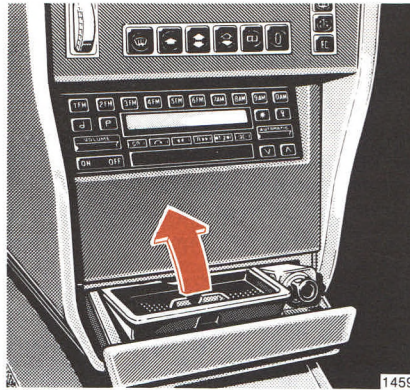

Ash tray

To remove front ash tray:

Open ash tray against stop. Place hand under tray. Pull frame up and out.

To remove rear ash tray:

Open ash tray against stop. Press down center spring and remove ash tray.

Installation:

Engage ash tray bottom into frame, push down release spring and close ash tray.

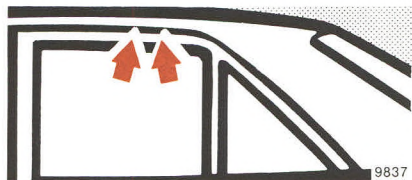

Roof Rack

Use only our approved roof rack to avoid damage to the vehicle.

Mount supports only between markings on border of roof which are visible when doors are opened.

Spare Parts Service

All MERCEDES-BENZ dealers maintain a stock of original spare parts required for maintenance and repair work. In addition, strategically located parts distribution centers provide quick and reliable parts service.

More than 200 000 different spare parts, even for older models, are available.

MERCEDES-BENZ original spare parts are subjected to most severe quality inspections. Each part has been specifically developed, manufactured or selected for and adapted to MERCEDES-BENZ vehicles.

Therefore, MERCEDES-BENZ original spare parts should be installed.

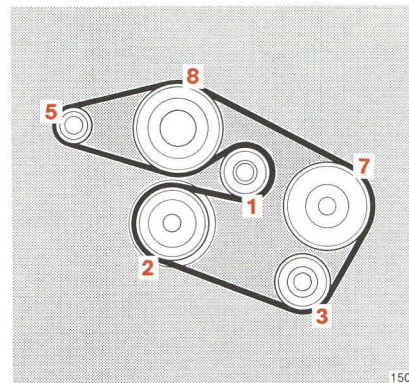

Layout of Poly V-belt Drive

- 1 Automatic belt tensioner
- 2 Crankshaft
- 3 Air conditioning compressor
- 5 Alternator
- 7 Power steering pump
- 8 Coolant pump–fan

Install the poly V-belt by starting at the belt tensioner (1) and proceed with the other pulleys in numerical order.

For dimensions of the poly V-belt, see page 90.

Technical Data Fuels, Coolants, Lubricants etc.

Identification Plates	88
Vehicle Data Cards	89
Warranty Coverage	89
Technical Data	90
Fuels, Coolants, Lubricants etc.	91
Capacities	91
Engine Oils	94
Brake Fluid	94
Fuel Requirements	94
Coolants	95
Consumer Information	96

Identification Plates

When ordering spare parts, please specify chassis and engine numbers.

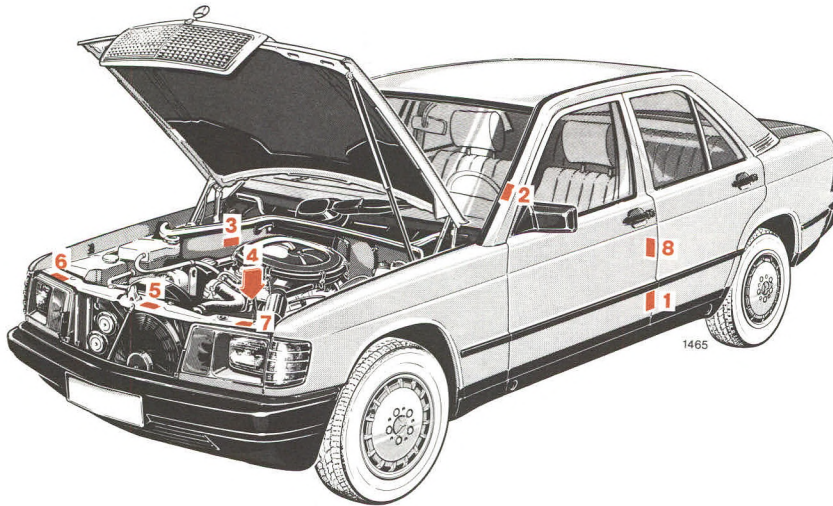

- 1 Certification Tag (left door pillar)
- 2 Identification Tag (left window post)
- 3 Vehicle Identification No.
- 4 Engine No.
- 5 Body No. and Paintwork No.
- 6 Information Tag
California version
Vacuum line routing for emission control system
- 7 Emission Control Tag
- 8 Emission Control Tag
Catalyst Information

Vehicle Data Cards

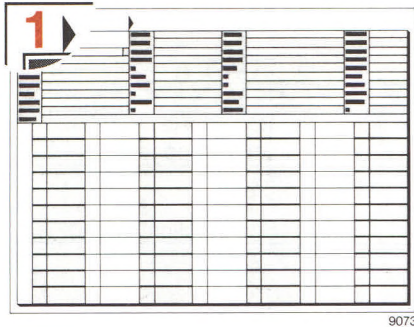

The vehicle data cards bear all the important data relating to your vehicle.

Data card No. 1 bears the key number and should never be left in the vehicle. Submit this card to your authorized MERCEDES-BENZ dealer to request a replacement key in case of loss.

Data card no. 2 has no key number information and should be kept in the Maintenance Booklet where indicated.

Warranty Coverage

Your car is covered under the terms of the “warranties” printed in the Owner’s Service and Warranty Policy Booklet, and your dealer will exchange or repair any defective parts in accordance with the terms of the following warranties:

1. New vehicle limited warranty
2. Emission systems warranty
3. Emission performance warranty
4. California emission control systems warranty (State of California only, unless purchased optionally for diesel models).

Loss of Owner’s Service and Warranty Policy

Should you lose your Owner’s Service and Warranty Policy Booklet, have your local MB dealer arrange for a replacement. It will be mailed to you.

Technical Data

Model	190 E 2.3 (201024) ¹
-------	---------------------------------

Engine

Engine type	102
Mode of operation	4-stroke engine, gasoline injection
No. of cylinders	4
Bore	95.5 mm (3.76 in)
Stroke	80.25 mm (3.16 in)
Total piston displacement	2299 cm ³ (140.3 in ³)
Compression ratio	8.0
Output acc. to SAE J 1349	90 kW/5000 rpm (121 hp/5000 rpm)
Firing order	1-3-4-2
Poly V-belt (single drive belt)	1980 mm

Rims – Tires

Rims (forged light alloy rims)	6 J×15 H 2
Wheel offset	49 mm (1.9 in)
Summer tires: Radial-ply tires	185/65 R 15 87 H
Winter tires: Radial-ply tires	185/65 R 15 87 Q M+S 185/65 R 15 87 T M+S

Electrical System

Alternator	14 V/70 A
Starter motor	12 V/1.4 kW
Battery	12 V/62 Ah
Spark plugs	see last page

Weights	See certification tag
---------	-----------------------

Main Dimensions

Overall vehicle length	4445 mm (175.0 in)
Overall vehicle width	1678 mm (66.1 in)
Overall height	1390 mm (54.7 in)
Wheel base	2665 mm (104.9 in)
Track, front	1437 mm (56.6 in)
Track, rear	1418 mm (55.8 in)

¹ The quoted data apply only to the standard vehicle. See an authorized MERCEDES-BENZ dealer for the corresponding data of all special bodies and special equipment.

Fuels Coolants Lubricants etc. Capacities

Vehicle components and their respective lubricants must match. Therefore use only brands tested and recommended by us. Inquire at your authorized MERCEDES-BENZ dealer.

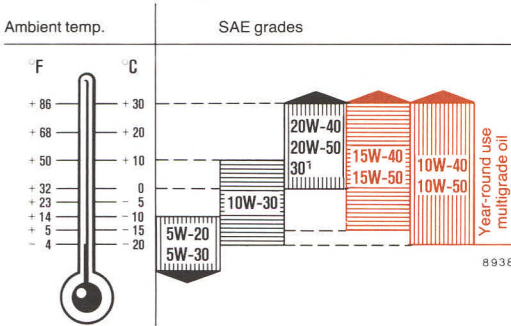
	Capacity	Fuels, coolants, lubricants, etc.
Engine with oil filter	5.0 l (5.3 US qt)	<p>Recommended engine oils</p>  <p>Ambient temp. SAE grades</p> <p>F °C</p> <p>+ 86 + 30</p> <p>+ 68 + 20</p> <p>+ 50 + 10</p> <p>+ 32 0</p> <p>+ 23 - 5</p> <p>+ 14 - 10</p> <p>+ 5 - 15</p> <p>- 4 - 20</p> <p>5W-20, 5W-30, 10W-30, 20W-40, 20W-50, 30¹, 15W-40, 15W-50, 10W-40, 10W-50</p> <p>Year-round use multigrade oil</p> <p>8938</p> <p>¹ SAE 40 may be used if ambient temperatures constantly exceed +30°C (+86°F).</p>

	Capacity	Fuels, coolants, lubricants, etc.
Manual transmission	1.5 l (1.6 US qt)	Automatic transmission fluid for manual transmission ¹
Automatic transmission	Initial fill: 6.6 l (7.0 US qt) Fluid change: 5.5 l (5.8 US qt)	Automatic transmission fluid for automatic transmission ¹
Rear axle	0.7 l (0.7 US qt)	Hypoid gear oil SAE 90, 85 W 90 ¹
Power steering	0.6 l (0.6 US qt)	Automatic transmission fluid for power steering ¹
Accelerator control linkage		Hydraulic fluid ¹
Front wheel hubs	approx. 50 g (1.8 oz) each	High temperature roller bearing grease

¹ For recommendations on recommended brands, see your nearest MERCEDES-BENZ dealer.

	Capacity	Fuels, coolants, lubricants, etc.
Battery terminals		Bosch special grease
Brake and (with manual transmission) clutch reservoir	approx. 0.5 l (0.5 US qt)	Brake fluid ¹
Windshield washer system	approx. 3.0 l (3.2 US qt)	Windshield washer solvent
Fuel tank including a reserve of	approx. 55 l (14.5 US gal) approx. 7.0 l (1.8 US gal)	Unleaded gasoline: Average Octane of Research and Motor 87 (RON of 91)
Cooling system	approx. 8.5 l (9.0 US qt)	Coolant ¹

¹ For recommendations on recommended brands, see your nearest MERCEDES-BENZ dealer.

Engine Oils

Engine oils are specifically tested for their suitability in our engines. Therefore, use only engine oils recommended by us. Information on recommended brands is available at any authorized MERCEDES-BENZ dealer.

Brake Fluid

During vehicle operation, the boiling point of the brake fluid is continuously reduced through the absorption of moisture from the atmosphere. Under extremely hard operating conditions, this moisture content can lead to the formation of vapor in the system thus reducing the system's efficiency.

The brake fluid must therefore be replaced annually, preferably in the spring.

It is recommended to use only brake fluid approved by MERCEDES-BENZ. Your MERCEDES-BENZ dealer will provide you with additional information.

Fuel Requirements

Use only unleaded gasoline meeting ASTM standard D 439:

The octane number (posted at the pump) must be **87 min.** It is an average of both, the Research (R) octane number and the Motor (M) octane number: $(R+M/2)$. This is also known as ANTI-KNOCK INDEX.

Unleaded gasoline containing oxygenates such as Ethanol, MTBE, IPA, IBA and TBA can be used provided the ratio of either one of these oxygenates to gasoline does not exceed 10%.

The ratio of Methanol to gasoline must not exceed 3%. In both cases, this does not include the cosolvents.

Using mixtures of Ethanol and Methanol is not allowed. MTBE may, however, be added up to 15%. Gasohol, which contains 10% Ethanol and 90% unleaded gasoline, can be used.

These blends must also meet all other fuel requirements such as resistance to spark knock, boiling range, vapor pressure, etc..

Coolants

The engine coolant is a mixture of water and anticorrosion/antifreeze, which provides:

- corrosion protection
- freeze protection
- boiling protection (by increasing the boiling point).

The cooling system was filled at the factory with a coolant providing freeze protection to -30°C (-22°F) and corrosion protection. The red area of the temperature gauge is matched to the heating properties of this coolant solution.

The coolant solution must be used year round to provide the necessary corrosion protection and increase in the boil-over protection. You should have it replaced every 3 years.

To provide the important corrosion protection, the solution must be at least 33% anticorrosion/antifreeze (equals a freeze protection to -20°C [-4°F]). If you use a solution that is more than

55% anticorrosion/antifreeze (freeze protection to -45°C [-49°F]), the engine temperature will increase due to the lower heat transfer capability of the solution. Therefore, do not use more than this amount of anticorrosion/antifreeze.

If the coolant level is low, water and MB anticorrosion/antifreeze should be used to bring it up to the proper level (have cooling system checked for signs of leakage).

The water in the cooling system must meet minimum requirements, which are usually satisfied by normal drinking water. If you are not sure about the water quality, consult your authorized MERCEDES-BENZ dealer.

Anticorrosion/antifreeze

Your vehicle contains a number of aluminium parts. The use of aluminium components in motor vehicle engines necessitates that anticorrosion/antifreeze/coolant used in such engines be specifically formulated to protect the aluminium parts. (Failure to use such anticorrosion/antifreeze/coolant will result in a significantly shortened service life.)

Therefore the following product, is strongly recommended for use in your car: MERCEDES-BENZ Anticorrosion/Antifreeze Agent.

Before the start of the winter season (or once a year in the hot southern regions), you should have the anti-corrosion/antifreeze concentration checked. The coolant is also regularly checked each time you bring your vehicle to your authorized MERCEDES-BENZ dealer for maintenance service.

Freeze protection	Anticorrosion/antifreeze
-30°C (-22°F)	3.75 l (4.0 US qt)
-45°C (-49°F)	4.50 l (4.8 US qt)

Consumer Information

This has been prepared as required of all manufacturers of passenger cars under Title 49, Code of U.S. Federal Regulations, Part 575 pursuant to the "National Traffic and Motor Vehicle Safety Act of 1966".

Uniform Tire Quality Grading

Relevant tire grade information on tire flanks.

All passenger car tires must conform to federal safety requirements in addition to these grades.

Treadwear

The treadwear grade is a comparative rating based on the wear rate of the tire when tested under controlled conditions on a specified government test course. For example, a tire graded 150 would wear one and a half (1 1/2) times as well on the government course as a tire graded 100. The relative performance of tires depends upon the actual conditions of their use, however, and may depart significantly from the norm due to variations in driving habits, service practices and differences in road characteristics and climate.

Traction "A", "B", "C"

The traction grades, from highest to lowest, are "A", "B" and "C" and they represent the tire's ability to stop on wet pavement as measured under controlled conditions on specified government test surfaces of asphalt and concrete. A tire marked "C" may have poor traction performance.

Warning!

The traction grade assigned to this tire is based on braking (straight-ahead) traction tests and does not include cornering (turning) traction.

Temperature "A", "B", "C"

The temperature grades of "A" (the highest), "B" and "C" representing the tire's resistance to the generation of heat and its ability to dissipate heat when tested under controlled conditions on a specified indoor laboratory test wheel. Sustained high temperature can cause the material of the tire to degenerate and reduce tire life, and excessive temperature can lead to sudden tire failure. The grade "C" corresponds to a level of performance which all passenger car tires must meet under the Federal Motor Vehicle Safety Standard No. 109. Grades "B" and "A" represent higher levels of performance on the laboratory test wheel than the minimum required by law.

Warning!

The temperature grade for this tire is established for a tire that is properly inflated and not overloaded. Excessive speed, underinflation, or excessive loading, either separately or in combination, can cause heat buildup and possible tire failure.

Vehicle Stopping Distance

This figure indicates braking performance that can be met or exceeded by the vehicles to which it applies, under different conditions of loading and with partial failures on the braking system. The information presented represents results obtainable by skilled drivers under controlled road and vehicle conditions, and the information may not be correct under other conditions.

Description of the vehicles to which this table applies: **190 E 2.3**

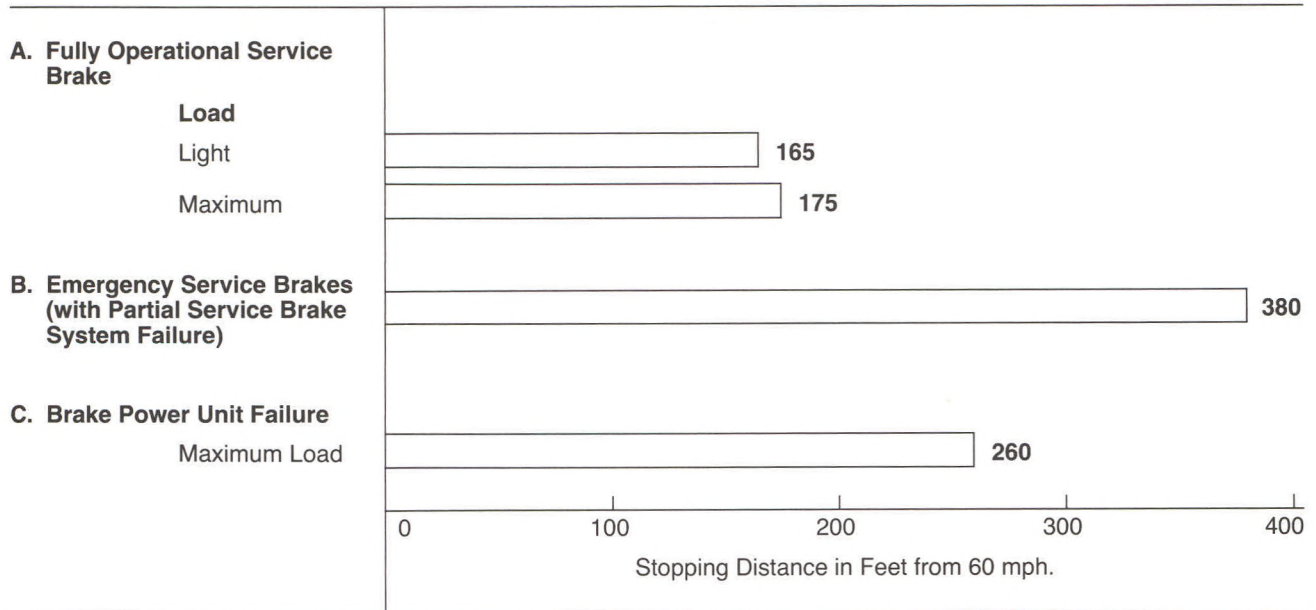



Airbag 37
Alarm system 29
Alloy wheels 83
Antenna 52
Anticorrosion/antifreeze 95
Arm rests 33
Ash trays 85
Automatic transmission 55
 Fluid level check 67

Battery 77
Body no. 88
Brake fluid 94
Brake pad wear
 indicator lamp 59
Brake, parking 54
Brakes 16
Brakes, ABS 58
Brake warning lamp 59
Break-in period 8

Capacities 91
Catalytic converter cautions 14
Central locking system 28
Certification tag 88
Charge indicator lamp 59
Cleaning and care of
 the vehicle 81
Combination switch 42
Consumer information 96
Coolant level check 65

Coolants 93, 95
Coolant temperature
 gauge 60
Cruise control 57

Doors 27
Driver checks 104
Driving hints 16

Economical driving indicator
 (ECONOMY) 61
Emergency tensioning
 retractors 35
Emission control 61
Emission control tag 88
Engine no. 88
Engine oil and
 filter change 18
Engine oil consumption 59
Engine oil level check 66
Engine oils 94
Engine starting
 and turning off 15
Exterior lamp switch 41

First aid kit 68
Fog lamps 72
Fuel filler flap 75
Fuel requirements 94
Fuel reserve warning
 lamp 60

Fuels, coolants,
 lubricants, etc. 91
Fuses 76

Gauges 12, 59, 60
 Oil pressure 59
 Coolant temperature 60
 Fuel 12

Headlamps 41, 72
Head restraints 30, 31, 33, 84
 front 30, 31, 84
 rear 33, 84
Heated seats 34
Hood 64

Identification plates 88
Indicator lamps 59, 60
 Brake pad wear 59
 Brake warning 59
 Charging system 59
 Fuel reserve 60
 Low coolant 60
 Low engine oil 59
 Low washer fluid 60
Instruments and controls 10
Instrument cluster 12

- Jack 68
- Jump starting 80
- Keys** 26
- Lamps, exterior** 72, 73, 74
 - Fog lamps 72
 - Headlamps 72
 - High mounted stop lamp 73
 - Licence plate lamps 74
 - Switch 41
 - Taillamps 73
- Lamps, interior** 44, 74, 75
 - Glove compartment 75
 - Sun visor 74
 - Trunk 75
- Lighter 46
- Literature 102
- Lubricants 91
- Maintenance** 4, 18
- Manual transmisson 54
- Oil pressure gauge** 59
- Orthopedic seat 32
- Outside temperature indicator 60
- Paintwork no.** 88
- Parking 17
- Parking brake 54
- Radio** 48
- Rear view mirrors 43
- Rear window defroster 45
- Recommended shift points for manual transmission 54
- Restraint systems, infants and children 39
- Roadside assistance 4
- Roof rack 86
- Seat belts** 35
 - Warning lamp and warning buzzer 35
- Seats 30, 31, 85
 - front 30, 31
 - rear 85
- Service literature 102
- Shelf below rear window 47
- Shifting 54
 - Automatic transmission 55
 - Manual transmission 54
 - Recommended shift points for manual transmission 54
- Sliding roof 46
 - Emergency operation 79
- Spare parts 86
- Spare wheel 68
- Spark plugs 76
- Starting and shifting gears 54
- Starting and turning off engine 15
- Steering lock 40
- Stowing things 68
- Sun visors 44
- Supplemental restraint system (SRS) 35
- Technical data** 90
- Tempmatic climate control system 20
- Tire chains 62
- Tire pressure 71
- Tires 16, 69, 96
- Tool kit 68
- Towing 78
- Traveling abroad 61
- Turn signals 42
- Unleaded gasoline** 93
- Upholstery, cleaning 83
- Vanity mirrors** 44
- V-belt 86, 90
- Vehicle data cards 89
- Vehicle identification no. 88
- Warranty** 4, 89
- Wheels 69
- Wheels, changing 70
- Windows 47
- Windshield washer system 42
- Winter driving 17, 62

Service Literature

Your authorized MERCEDES-BENZ dealer has trained technicians and original MERCEDES-BENZ parts to service your vehicle properly. For expert advice and quality service, see your authorized MERCEDES-BENZ dealer.

Customers who are interested in ordering service literature for their vehicles are advised to contact MERCEDES-BENZ distributors in the U.S. or Canada at the following addresses, respectively

for U.S.A.: Mercedes-Benz of North America Inc.
One Mercedes Drive
P. O. Box 350
Montvale, New Jersey 07645
Att: Technical Publications
Tel: (201) 573-0600

for Canada: Mercedes-Benz Canada Inc.
849 Eglinton Ave., East
Toronto, Ont., Canada
M4 G2 L5
Att: Technical Publications
Service Department
Tel: 416-425-3550
Telex: 065-24232

The above companies will be happy to handle any such requests from customers.

We consider this to be the best way to obtain accurate information for your vehicle.

Warning!

To help avoid personal injury, be extremely careful when performing, any maintenance work or repairs. Improper or incomplete service may damage the vehicle or its equipment, which may in turn result in personal injury.

If you have any question about carrying out some service, turn to the advice of an authorized MERCEDES-BENZ dealer.

Check Regularly and Before a Long Trip

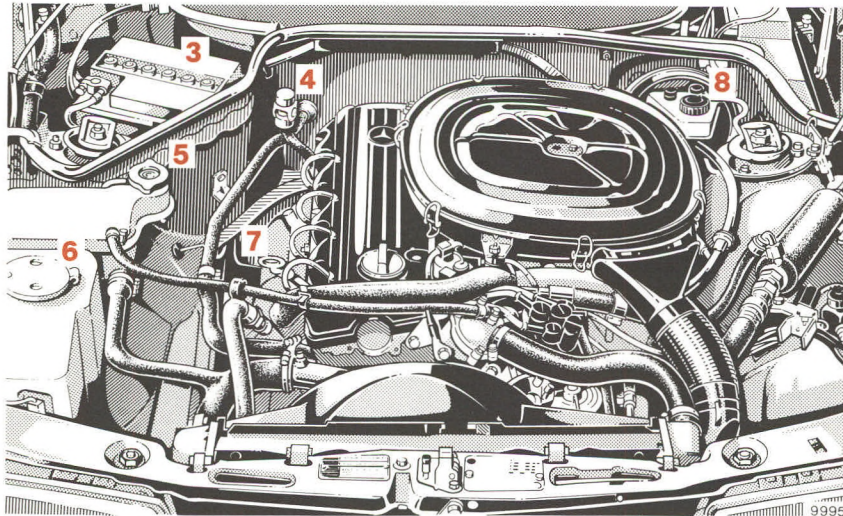
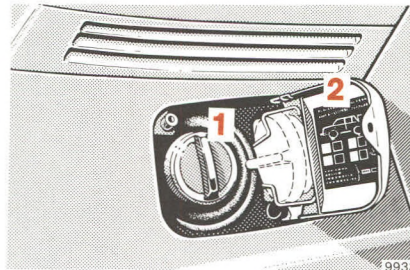
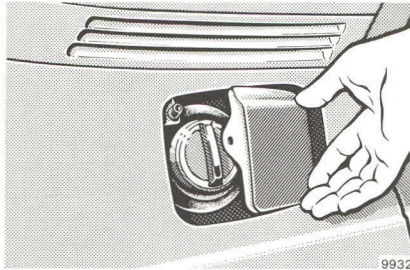

- 1 Fuel Supply:** Turn fuel filler cap to the left and hold on to it until possible pressure in tank has been released.
- 2 Tire Inflation Pressure:** Check at least every two weeks. For details see page 71.
- 3 Battery:** Add distilled water only, see page 77.
- 4 Fluid Level in Automatic Transmission:** See page 67.
- 5 Coolant Level:** See page 65.
- 6 Windshield Washer System:** See page 93.
- 7 Engine Oil Level:** See page 66.
- 8 Brake Fluid:** See pages 93 and 94.

Vehicle Lighting: Check function and cleanliness. For replacement of light bulbs, see pages 72 and 73.

What You Should Know at the Gas Station

- **Fuel:** Unleaded gasoline: Average Octane of Research and Motor 87 (RON of 91).

Fuel tank capacity approx. 55 l (14.5 US gal). This includes approx. 7.0 l (1.8 US gal) reserve.

Only fill fuel tank until the discharge nozzle unit cuts out – do not overfill.

- **Engine Oil:** Engine oil level check, see page 66.

Quantity differential between upper and lower dipstick marking level: 2.0 l (2.1 US qt).

Year-round multigrade oils 10 W-40, 10 W-50, 15 W-40, 15 W-50.

For further information, refer to page 91.

- **Automatic Transmission:** Automatic transmission fluid for automatic transmission.

For level checks and replenishment, refer to page 67.

- **Coolant:** For normal replenishment, use water (potable water quality).

For further information (e.g. anticorrosion/antifreeze), refer to page 95.

- **Bulbs:** High and low beams: Sealed beam/Halogen, tail, parking and standing lamps 10 W/6 cp, turn signal, standing, side marker and parking lamps, front 21/5 W/32/3 cp, turn signal lamps, rear 21 W/32 cp, stop lamps 21 W/32 cp, license plate lamps 5 W lamp.

- **Spark plugs:** Bosch H 8 D, H 8 DC, Beru 14 K-8 D, 14 K-8 DU, Champion S 12 YC.

- **Tire Pressure:**
For driving up to
160 km/h (100 mph)

Cold tires:

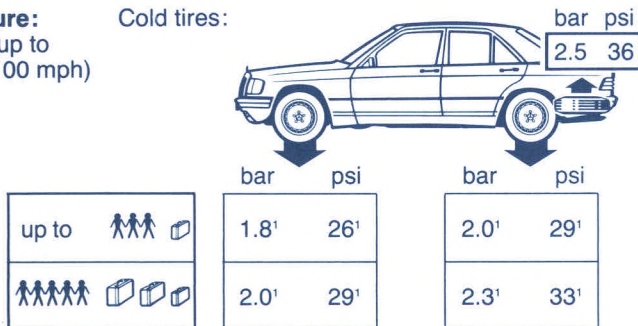

Warm tires:

Pressure may rise by up to
+0.3 bar (+4 psi).

Never release any air from a
warm tire to off-set this pressure increase.

¹ For driving above 160 km/h (100 mph)
+0.3 bar (+4 psi).

DAIMLER-BENZ AG
Stuttgart-Untertuerkheim
Zentralkundendienst



Mercedes-Benz
service

