

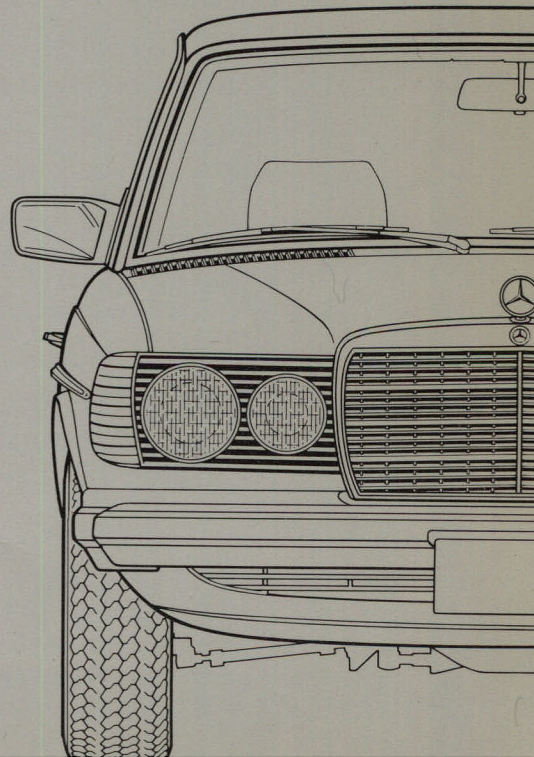

Owner's Manual

300 D-
TURBO DIESEL
300 CD-
TURBO DIESEL

1985



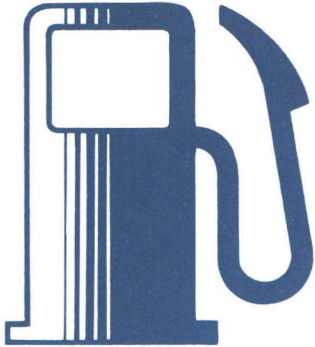

41

Drive Sensibly — Save Fuel

Fuel consumption depends to a great extent on driving habits and operating conditions.

In order to save fuel you should:

- ensure that tire pressures are correct
- not carry unnecessary loads
- remove ski racks or roof-mounted luggage racks when not in use
- not warm up your engine at idle and with the vehicle at standstill
- avoid frequent acceleration and deceleration
- have all the maintenance jobs specified by us carried out at regular intervals by an authorized MERCEDES-BENZ dealer.

Driving in low temperature weather, in stop-and-go city traffic and on short hops, and in hilly country as well, increases fuel consumption.



Owner's Manual

**300 D-
TURBO DIESEL**
**300 CD-
TURBO DIESEL**

1985

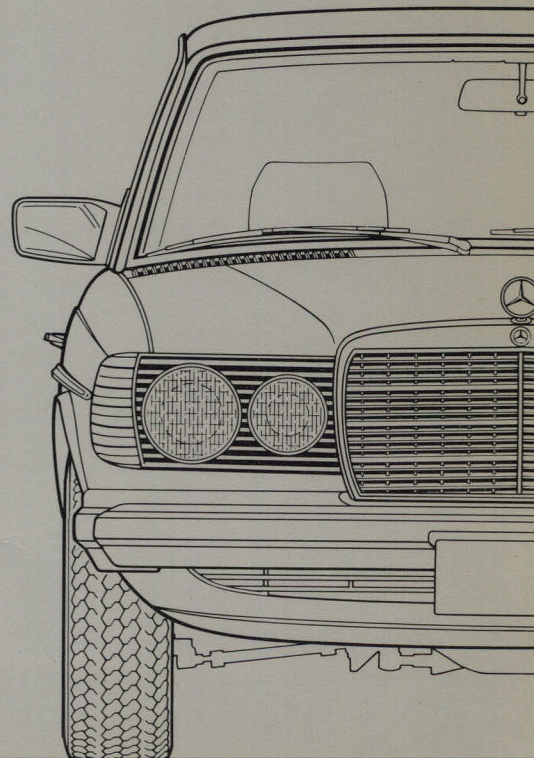

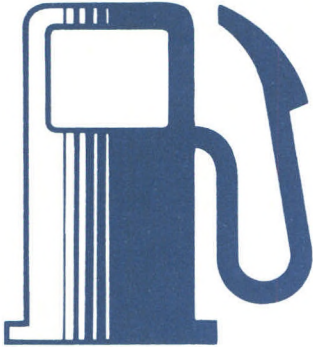

41

Drive Sensibly — Save Fuel

Fuel consumption depends to a great extent on driving habits and operating conditions.

In order to save fuel you should:

- ensure that tire pressures are correct
- not carry unnecessary loads
- remove ski racks or roof-mounted luggage racks when not in use
- not warm up your engine at idle and with the vehicle at standstill
- avoid frequent acceleration and deceleration
- have all the maintenance jobs specified by us carried out at regular intervals by an authorized MERCEDES-BENZ dealer.

Driving in low temperature weather, in stop-and-go city traffic and on short hops, and in hilly country as well, increases fuel consumption.

Mercedes-Benz



Owner's Manual

300 D- TURBO DIESEL 300 CD- TURBO DIESEL

Chassis 123 D

1985

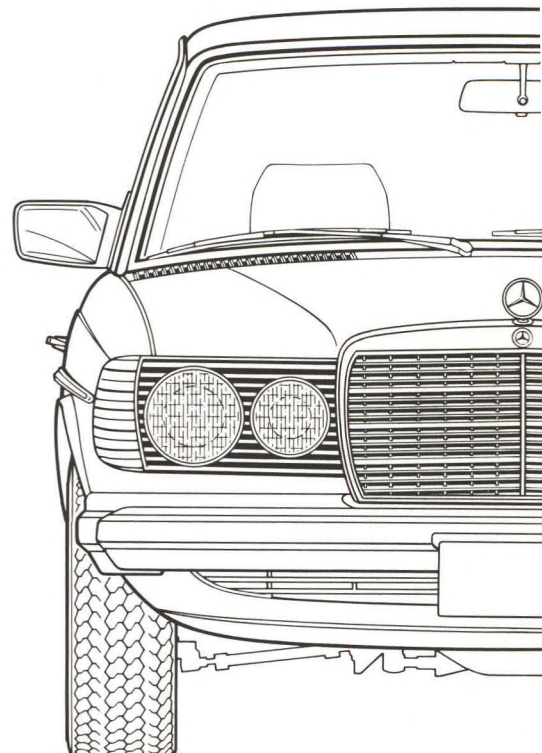

Our company and staff wish you many hours of enjoyment with your new vehicle.

You have placed a lot of trust in our company name by purchasing a MERCEDES, from which you may expect that it will give you long service with a minimum of trouble, and is easy to operate.

We have just one request to make, hoping that it will benefit you as well:

Please do not put this manual aside without first carefully reading it.

You may notice that it contains many important recommendations that should make the operation of your MERCEDES easier and even increase your pleasure driving it.

We wish you many miles of motoring pleasure.
Daimler-Benz Aktiengesellschaft

Contents

Special equipment is also described in this manual, including operating instructions wherever necessary. Since there are special-order items, the descriptions and illustrations herein may vary slightly from the actual equipment of your vehicle.

If there are any equipment details that are not shown or described in this Owner's Manual, your MERCEDES-BENZ dealer will be glad to inform you of correct care and operating procedures.

The last page

What you should know at the gas station

Vehicle Operation

Instruments and Controls	8
Instrument Cluster	10
Keys, Doors	12
Master and Supplementary Keys	12
Opening, Locking and Unlocking of Doors	12
Central Locking System	13
Anti-Theft Alarm System	14

Seats	15
Adjustment of Driver's Seat and Front Passenger Seat	15
Seat Heater	16
Safety Head Restraints	17
Arm Rest (Rear Seat)	18
Arm Rest (Front Seats)	18
Seat Belts (300 CD-TURBO DIESEL)	19
Supplemental Restraint System-Seat Belts, Emergency Tensioning Retractors (300 D-TURBO DIESEL)	21
Controls	24
Steering Lock	24
Lighting Switch	25
Combination Switch	26
Cruise Control	27
Automatic Climate Control	28
Various Equipment	33
Exterior Mirrors	33
Inside Rear View Mirror	33
Sun Visors	34
Heated Rear Window	34
Interior Lamps	35
Shelf below Rear Window	35
Power Windows	36
Lighter	37
Sliding Roof	37
Radio	38

Driving

Hood	46
Regular Inspections	47
Parking Brake	48
Starting and Turning off the Engine	48
Starting and Shifting Gears	50
Safe Driving	52
Brake Pad Wear Indicator Lamp	53
Brake Fluid	53
Charge Indicator Lamp	53
Fuel Reserve Warning Lamp	53
Oil Pressure Gauge	54
Coolant Temperature Gauge	54
Emission Control	54
Engine Oil Consumption	54
The First 1500 km/1000 Miles	55
Special Operating Conditions	55
Winter Driving	55
Hints for Driving	56
High Altitude Correction Device	56
Tire Chains	56
Traveling Abroad	56

Vehicle Care

MERCEDES-BENZ

Maintenance System	58
Spare Parts Service	59
Cleaning and Care of the Vehicle	59
Jobs related to Care	60

Practical Hints

Ash trays	64
Rear Seat Cushion	64
Bleeding the Fuel System	65
Turning off Engine Manually	65
First Aid Kit	66
Luggage or Ski Racks	66
Spare Wheel, Jack, Vehicle Tool Kit	66
Wheels, Tires, Changing Wheels	67
Wheels, Tires	67
Changing Wheels	68
Tire Pressure	68
Checking Fuels, Coolants, Lubricants, etc.	69
Engine Oil Level Check	69
Checking Coolant Level	70
Adding Coolant	70
Automatic Transmission Fluid Level	71

Electrical System	72
Headlamp Adjustment	72
Replacing Bulbs	72
Fuses	76
Battery	76
Emergency Operation of Sliding Roof	77
Unlocking of the Filler Flap	77
Tow-starting and Towing the Vehicle	78
Jump Starting	79

Technical Data — Fuels, Coolants, Lubricants, etc.

Identification Plates	82
Vehicle Data Cards	83
Warranty Coverage	83
Technical Data	84
Fuels, Coolants, Lubricants, etc.	86
Capacities	86
Engine Oils	88
Brake Fluid	88
Diesel Fuels	89
Coolants	90
Service Literature	91
Consumer Information	92

Vehicle Operation ▶

Driving ▶

Vehicle Care ▶

Practical Hints ▶

Technical Data — Fuels, Coolants, Lubricants, etc. ▶

Vehicle Operation



Instruments and Controls

For more detailed descriptions see quoted pages.

- 1 Speaker grilles
- 2 Swivelling side ventilation outlets (page 28)
- 3 Parking brake release knob (page 48)
- 4 Hood lock release handle (page 46)
- 5 Parking brake pedal (page 48)
- 6 Combination switch (page 26)
- 7 Lighting switch (page 25)
- 8 Cruise control (page 27)
- 9 Instrument cluster (page 10)
- 10 Horn control
- 11 Steering lock with preglow/starter switch (page 24)
- 12 Swivelling outlets for cooled air (page 28)
- 13 Switch for rear courtesy lamp (page 35)
- 14 Switch for automatic antenna (page 43)
- 15 Switch for electric sliding roof (page 37)
- 16 Switch for heated rear window (page 34)
- 17 Automatic climate control (page 28)
- 18 Radio (page 38)
- 19 Ash tray with lighter (pages 37, 64)
- 20 Switch for left front seat heater (page 16)
- 21 Switch for hazard warning flasher system
- 22 Switch for right front seat heater (page 16)
- 23 Switch group for power windows (page 36)
- 24 Adjusting lever for exterior mirror on front passenger side (page 33)
- 25 Loudspeaker — fader control
- 26 Glove compartment, illuminated (only if steering lock is in position "1" or "2")
To open, move handle sideways

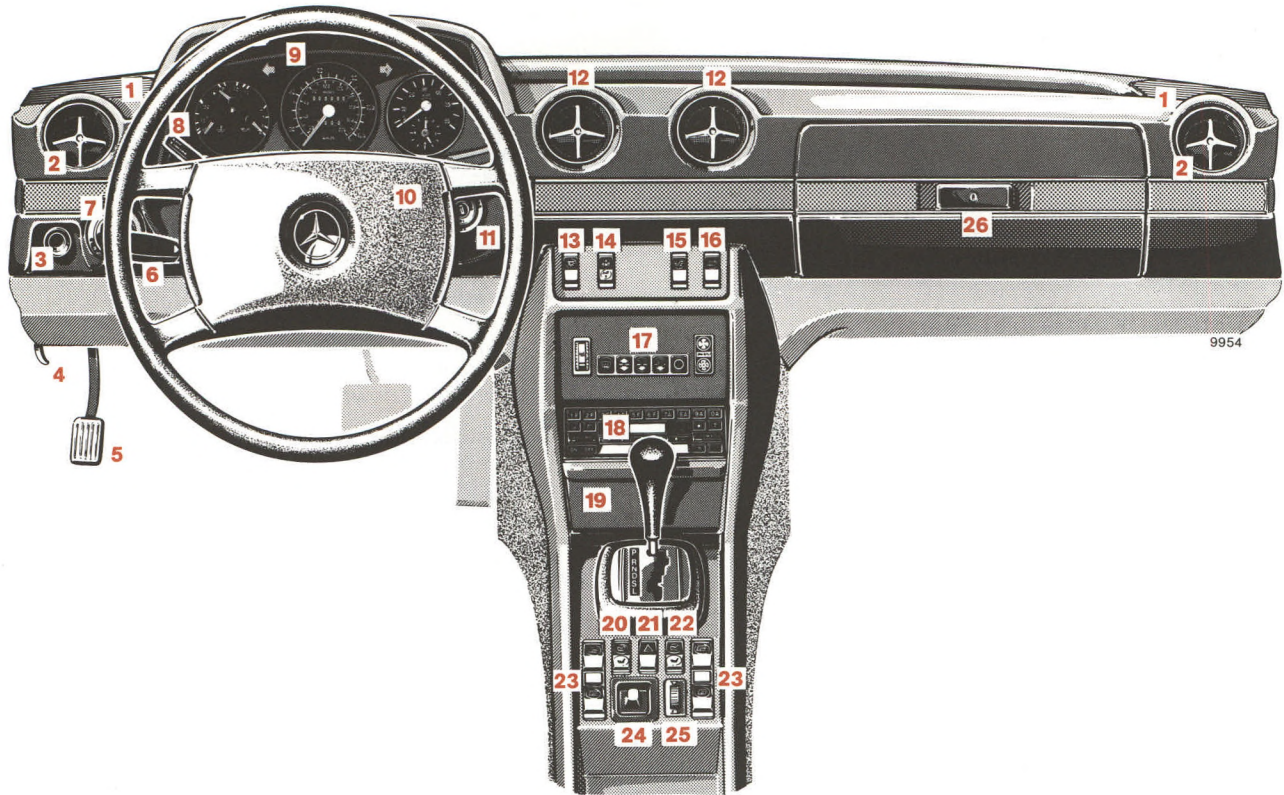

Instrument Cluster

- 
- 1** Coolant temperature gauge
Up to red marking: Maximum permissible temperature for an anticorrosion/antifreeze-blended fill protecting down to -30°C / -22°F . See page 54
 - 2** Fuel gauge with reserve warning lamp (yellow):
Comes on when the steering lock key is moved to driving position "2" and must go out when the engine is idling. See page 53
Fuel reserve and capacity, refer to page 87 and last page
 - 3** Oil pressure gauge (bar). See page 54
 - 4** Turn signal indicator lamp, left (green)
 - 5** Main odometer
 - 6** Trip odometer
 - 7** Turn signal indicator lamp, right (green)
 - 8** Tachometer
 - 9** Electric clock
 - 10** Preglow indicator lamp (yellow)
 - 11** Seat belt warning lamp (red)
 - 12** Knob for clock adjustment
(press in for adjustment)
 - 13** Knob for instrument lamps and trip odometer
Rotate knob: instrument lamps intensity are infinitely variable
Depress knob: trip odometer is reset
 - 14** Brake warning lamp (red) comes on if
 - the parking brake is engaged
 - too little brake fluid is in the reservoir
 - 15** Brake pad wear indicator lamp (yellow):
Lights up during braking if the front wheel brake pads are worn down. See page 53
 - 16** Charge indicator lamp (red):
Comes on when the steering lock key is moved to driving position "2" and must go out when the engine is idling. See page 53
 - 17** High beam indicator lamp (blue)

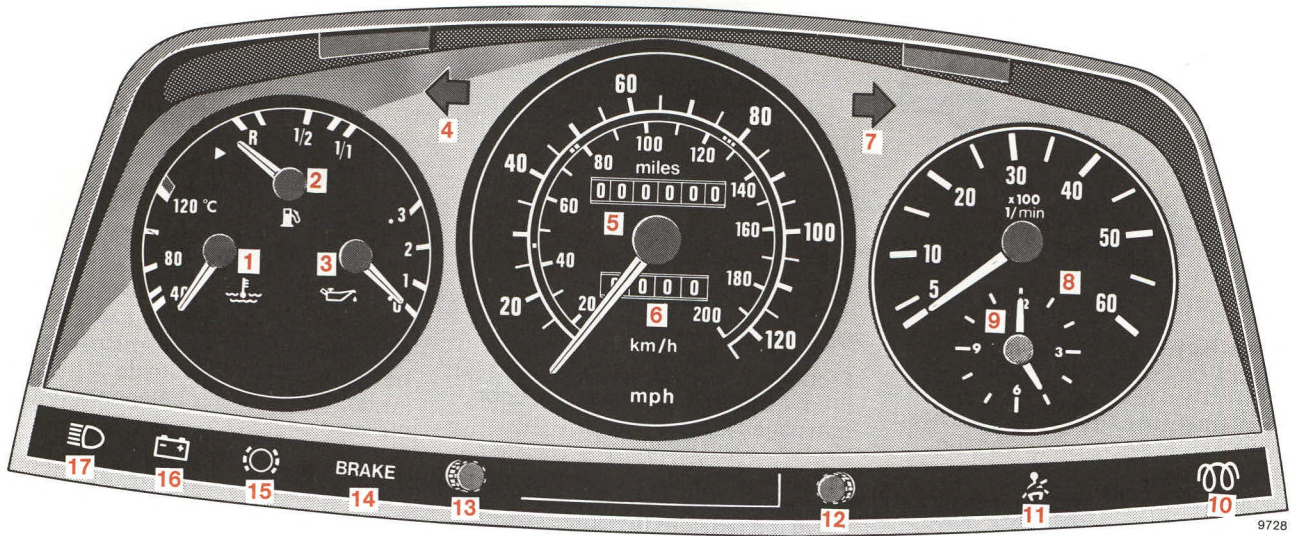

9728

Keys Doors

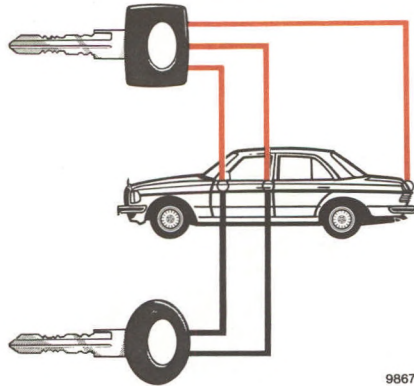

9867

Master Key — square-head — fits all locks on the car.

Supplementary Key — rounded head — fits only the door locks and the steering lock. This key is intended to be used whenever the car is left with an attendant. Be sure to lock glove compartment and trunk with the master key.

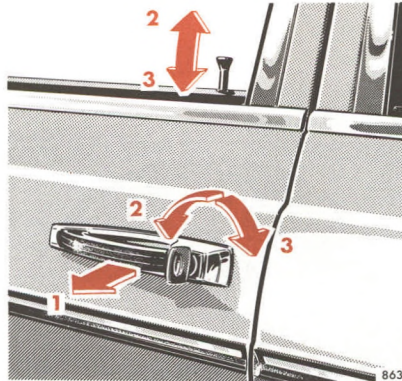

8637

Sedan

Opening the Doors

From outside: pull handle outwards (1).
From the inside: pull handle in door trim panel.

Locking and Unlocking of Doors

From the outside: turn key.
From the inside: actuate safety plunger (sedan) or safety lever (coupé).

- 2 Unlocking
- 3 Locking

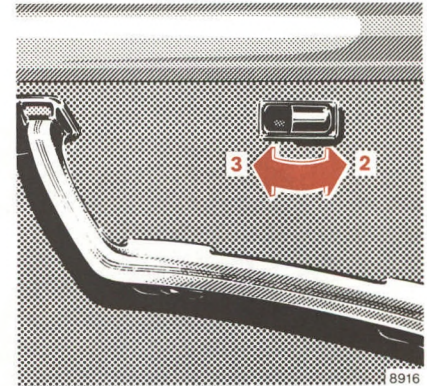

8916

Coupé

When the rear door plunger's are pushed down the rear doors cannot be opened from the outside or the inside. They can only be opened after pulling plungers up.

The driver's door can be locked only if it is closed and the door lock has properly engaged.

Central Locking System

The central locking system simultaneously locks or unlocks together with the driver's door all other doors, fuel tank filler flap and trunk lid. As the driver's door button is moved, the buttons of all other doors must move at the same time. If this is not the case, the lock of the corresponding door has not engaged fully. Open the door once more and close it correctly. When the central locking system has been engaged, the lock buttons of the front passenger door and the rear doors can also be operated manually from inside. In addition to this, the front passenger door can be locked or unlocked by means of the master key.

The central locking system can only be engaged by depressing the button on the driver's door. Lock buttons of the other doors cannot be depressed individually.

The trunk lid can also be unlocked separately by turning the master key

counterclockwise to the stop. Push the trunk lock button in with it and lift the lid. Return the key to its initial position and withdraw it. To lock the lid, close it firmly. It will then be locked again by the central locking system.

A provision has been made to facilitate permanent locking of the trunk lid for positive prevention of access to trunk by unauthorized persons.

Before leaving vehicle with an attendant, lock trunk with master key (square head) by turning key clockwise to stop (tumbler slot vertical), then provide attendant with round-headed supplementary key. Thus, the trunk lock has been excluded from the operation of the central locking system and cannot be opened except with the squareheaded master key that you keep in your possession.

To reverse this, turn trunk lock counterclockwise back to horizontal position of the tumbler slot with master key. Lock will then be

re-engaged in central locking system; that is, it will automatically be locked or unlocked depending on whether the driver's door is locked or unlocked.

The central locking system operates on vacuum generated by the engine. A reservoir allows the central locking system to be actuated about five times after the engine is turned off. If the system can then no longer be engaged, idle engine for a short period.

If no vacuum is available, doors and trunk have to be locked individually using a key or depressing the button. The fuel tank filler flap, however, remains unlocked.

Note:

If the filler flap cannot be opened when the central locking system is unlocked, refer to "Unlocking of the Filler Flap" (page 77).

Anti-Theft Alarm System

The anti-theft alarm can be armed or disarmed by locking or unlocking the front doors with the master key or the supplementary key.

With the alarm system armed an additional horn will sound intermittently for approx. 30 seconds if an unauthorized person opens a door, the

hood or the trunk lid, turns or bridges the steering lock or actuates the service brake. It keeps on sounding for approx. 30 seconds even if the triggering component (e.g. the door) is closed again immediately.

Special functions:

The trunk lid can be opened only when the alarm system is disarmed.

Trunk lid emergency release:

If the trunk lid cannot be opened with the alarm system disarmed, it can be opened by means of an emergency control. For this purpose, remove rear seat cushion and fold back LH cover. Then pull the ring of the emergency release cable while another person at the same time opens the trunk lid.

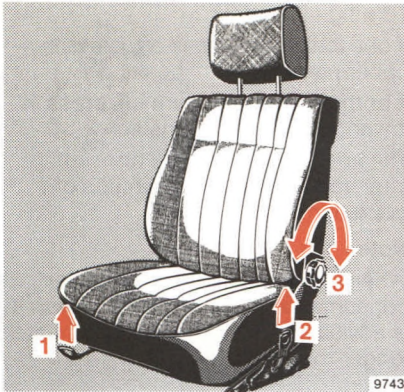

9743

Adjustment of Driver's Seat and Front Passenger Seat

Fore/aft adjustment: lift handle (1); slide seat to desired position and allow handle to re-engage.

Height of seat: raise lever (2); to raise seat, slide seat forward; to lower seat, slide seat backward; allow lever to re-engage.

Seat back position: turn handwheel (3). For full reclining of backrest, seat should be moved to one of the forward-most positions and headrest removed. For driving, return backrest

to upright position and push seat back. Replace headrest.

Note:

Prior to operating the vehicle, the driver should adjust the seat height for proper vision as well as fore/aft placement and seat back angle to insure adequate control, reach, operation, and comfort. Be certain seat is "locked in" by sliding front/rear until full engagement is assured.

The headrest should also be adjusted for proper height so that when the cushion is tipped completely forward, it should form a cradle behind the seat occupant's head. Both the inside and outside rear view mirrors should then be adjusted for adequate rearward vision. Fasten seat belts. Children under the age of six or under the weight of 23 kg/50 lb should be seated in the back seat with an approved restraint system properly secured.

All seat, head restraint, and rear view mirror adjustments as well as fastening of seat belts should only be accomplished before the vehicle is put into motion.

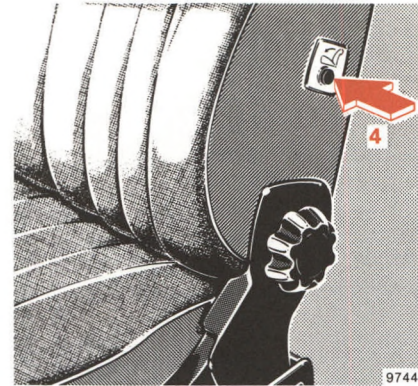

9744

Coupé: For safety, when the doors are closed the backrests are locked by means of vacuum. The locks can be released by pushing button (4). When the doors are opened the backrests can be folded forward without pushing the button (4).

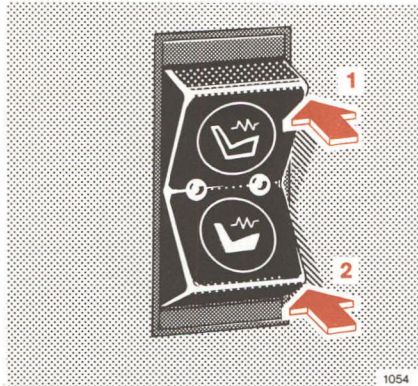

Seat Heater

The seat heater can be switched on when the steering lock is in position "1" or "2".

Heater operation:

Push in upper switch portion; position 1 = normal heater operation, one indicator lamp lights up.

Push in lower switch portion; position 2 = rapid heating, both indicator lamps light up.

After approximately 5 minutes in the rapid heating mode, the heater automatically switches to normal operation and only one indicator lamp will stay on.

Turning off heater:

If one indicator lamp is on, press in upper part of switch, position 1.

If both control lamps are on, press in lower part of switch, position 2.

The heater automatically turns off after approximately 30 minutes of operation.

Note:

When in operation, the seat heater consumes a large amount of power. It is advisable not to use the seat heater longer than necessary.

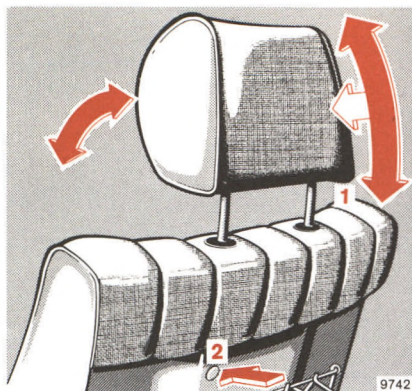

Safety Head Restraints

Adjust head restraint to support the back of the head approximately at ear level. Do not extend the head restraint past the stop.

Safety head restraints, front

Height adjustment:

Pull head restraint slightly forward (1) and slide up or down as required.

Removing head restraints:

Pull head restraint up to the stop.

Depress release button (2) to be felt under the seat back covering material and pull head restraint upward quickly, holding it by the LH head restraint post (viewed in driving direction). Then pull out head restraint completely with both hands.

Safety head restraints, rear

Height adjustment:

Pull head restraint slightly forward and slide up or down as required.

Removing head restraints:

Pull up head restraint until resistance can be felt. Then pull it out quickly using both hands.

Note:

For your protection, drive only with properly positioned head restraints.



Arm Rest (Rear Seat)

A center arm rest is provided in the rear seat which can be pulled out with a loop.

When replacing, lift at the rear.

For the removal of the rear seat cushion see "Practical Hints".

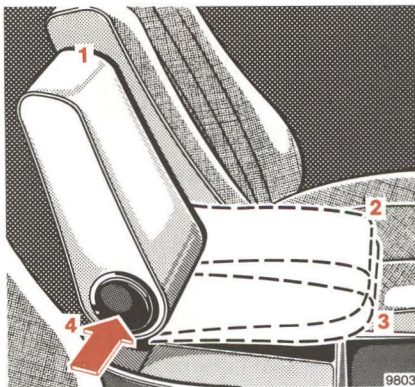

Arm Rest (Front Seats)

The arm rest engages in 3 positions.

Position 1 = arm rest folded up.

Position 2 = for normally inclined seat back.

Position 3 = for extremely inclined seat back.

For downward adjustment of the arm rest, depress release button 4.

Warning!

The arm rest does not suffice as a child restraint system. In case of a frontal collision a child can be catapulted forward over the locked arm rest.

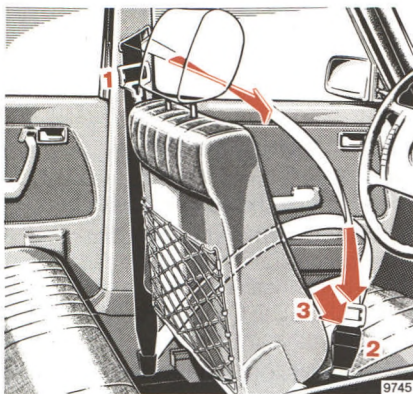

Seat Belts (300 CD-TURBO DIESEL)

Warning system:

The indicator is illuminated for 4 – 8 seconds after turning the steering lock key to position "2". If the seat belt of the driver's seat is not fastened a warning buzzer sounds simultaneously.

Fastening:

- Pull belt with latch plate (1) over shoulder and lap. The belt must not be twisted.

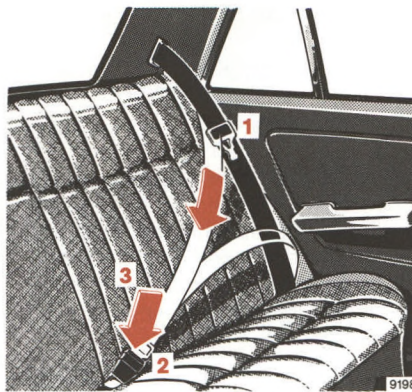

Unfastening:

- Depress red button (3) in buckle.
- Return latch plate (1) to initial position.

Operation:

The inertia reel stops the belt from unwinding during sudden vehicle stops or when quickly pulling on the belt.

Functional test:

The locking function of the inertia reel can be tested by pulling the belt out quickly.

- Press latch plate (1) into buckle (2) until it clicks.
- The belt must be pulled snug and checked for snugness immediately after engaging it and during driving. If necessary, tighten the lap portion to a snug fit by pulling shoulder portion up.

On the coupé, the swivel fitting which is mounted on the lower anchoring point to facilitate entering the vehicle must point forward.

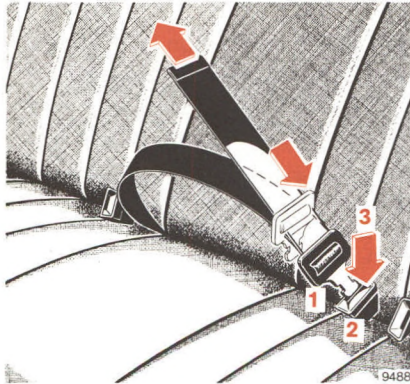

Lap belt in rear passenger compartment:

Pull belt with latch plate (1) across the lap, and push latch plate into buckle (2) until it clicks. The belt must not be twisted and must be tight.

To shorten the belt, pull belt end with the tongue engaged. To lengthen the belt, turn the latch plate so that it is at a little more than 90° to the belt and pull before fastening the belt.

To disengage the belt, push red button (3) in the buckle.

Note:

Rear seat passengers should always wear seat belts — for their own protection and to avoid endangering the driver and front passenger with their unrestricted forward movement.

No seat belt can be used for more than one person. Children under the age of six or under the weight of 23 kg/50 lb should be seated in the back seat with an approved restraint system properly secured.

After an accident, inspect the seat belts and replace them, if required.

Child restraint systems recommended by us can be fastened to the seat belts installed. Any MERCEDES-BENZ dealer will gladly advise you accordingly.

The belt anchors in the vehicle should also be checked.

Belts must not be routed via sharp edges.

Replace damaged seat belts immediately.

No modifications which may affect the efficiency of the belts must be made.

For cleaning and care of belt webbing, refer to page 60.

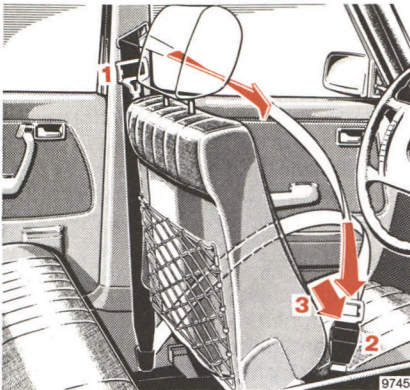

Supplemental Restraint System — Seat Belts, Emergency Tensioning Retractors (300 D-TURBO DIESEL)

Your vehicle is equipped with seat belts for all seats and emergency tensioning retractors for front seats. The tensioning retractors are located in each belt's inertia reel and become operationally ready with the steering lock key in position "1" or "2".

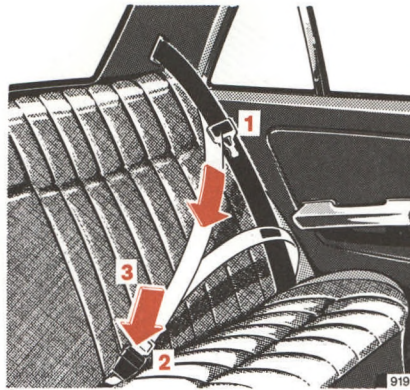

Warning system:

The indicator is illuminated for 4–8 seconds after turning the steering lock key to position "2". If the seat belt of the driver's seat is not fastened a warning buzzer sounds simultaneously.

Fastening:

- Pull belt with latch plate (1) over shoulder and lap. Do not twist the belt doing this.
- Push latch plate (1) into buckle (2) until it clicks.

- The belt must be pulled snug and checked for snugness immediately after engaging it and during driving. If necessary, tighten the lap portion to a snug fit by pulling shoulder portion up.

Unfastening:

- Push in the red button (3) in the belt buckle.
- The retractor should completely rewind the belt and latch plate (1).

Operation:

The inertia reel stops the belt from unwinding during sudden vehicle stops or when quickly pulling on the belt.

The locking function of the reel may be checked by quickly pulling out the belt.

Seats

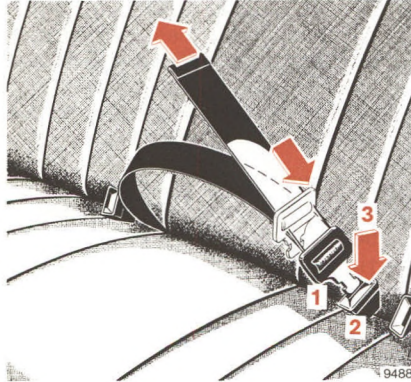

Lap belt in rear passenger compartment:

Pull belt with latch plate (1) across the lap, and push latch plate into buckle (2) until it clicks. The belt must not be twisted and must be tight.

To shorten the belt, pull belt end with the tongue engaged. To lengthen the belt, turn the latch plate so that it is at a little more than 90° to the belt and pull before fastening the belt.

To disengage the belt, push red button (3) in the buckle.

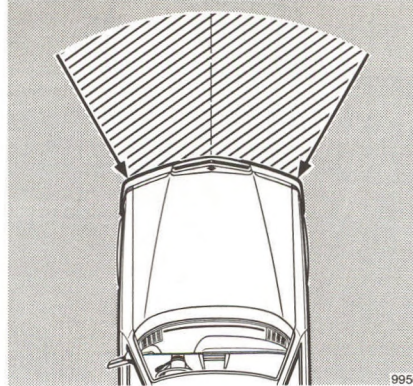

The emergency tensioning retractors are designed to activate only during severe frontal impacts. They tighten the belts in such a way that they fit more snugly against the body restricting as much as possible its forward movement.

In cases of less severe frontal impacts, such as roll-overs, side or rear collisions, or other accidents without severe frontal forces, the emergency tensioning retractors will not be activated. The driver and passengers will then be protected by the fastened seat belts and inertia reel in the usual manner.

Notes:

Rear seat passengers should always wear seat belts — for their own protection and to avoid endangering the driver and front passenger with their unrestricted forward movement.

No seat belt can be used for more than one person. Children under the age of six or under the weight of 23 kg/50 lb should be seated in the back seat with an approved restraint system properly secured.

Child restraint systems recommended by us can be fastened to the existing seat belts. Any authorized MERCEDES-BENZ dealer will gladly advise you on this subject.

For cleaning and care of the seat belts, see page 60.

Safety Guidelines for the Seat Belts and Emergency Tensioning Retractors

Damaged belts or belts that were highly stressed in an accident must be replaced and their anchoring points must also be checked. Use only belts installed or supplied by MERCEDES-BENZ.

Do not pass belts over sharp edges.

Do not make any modification that could change the effectiveness of the belts.

A tensioning retractor that was activated must be replaced.

No modifications of any kind may be made to any components or wiring of the emergency tensioning retractor.

Improper work on the system, including incorrect installation and removal, can lead to possible injury through an uncontrolled activation of the emergency tensioning retractor. In addition, through improper work there is the risk of rendering the emergency tensioning retractor inoperative. Work on the emergency tensioning retractor

must therefore only be performed by an authorized MERCEDES-BENZ dealer.

When scrapping the emergency tensioning retractor, it is mandatory to follow our safety instructions. These instructions are available at every authorized MERCEDES-BENZ dealer.

When you sell the vehicle we strongly urge you to give notice to the subsequent owner if it is equipped with an emergency tensioning retractor by alerting him to the applicable section in the Owner's Manual.

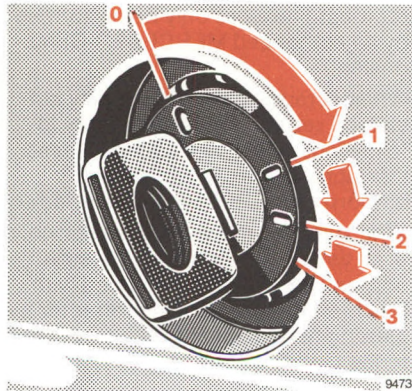

Steering Lock

- 0 Steering is locked when the key is withdrawn and the steering lock is engaged. The key can be withdrawn only in zero position.

Note:

Do not remove key from steering lock while the vehicle is in motion as this will cause the engagement of the steering lock thus rendering the vehicle inoperable.

- 1 Steering is unlocked. (If necessary, move steering wheel slightly to turn the key clockwise to position "1".)
- 2 Preglowing and driving position.
- 3 Starting position.

For starting and turning off the engine, refer to page 48.

Notes:

The following items can be operated with the key in steering lock position "1":

Wiper, windshield washer, headlamp flasher, lighter, glove compartment lamp, radio, seat heater, electrically adjustable exterior mirror.

A warning buzzer sounds when the key has been left in steering lock positions "1" or "0" and the driver's door is opened.

With the engine at idle speed, the charging rate of the alternator (output) is limited.

It is therefore recommended to turn off unnecessary electrical consumers while driving in stop and go traffic. This precaution helps to avoid draining of the battery.

An effective measure to preserve battery power is to turn off the following consumers:

Seat heater, heated rear window.

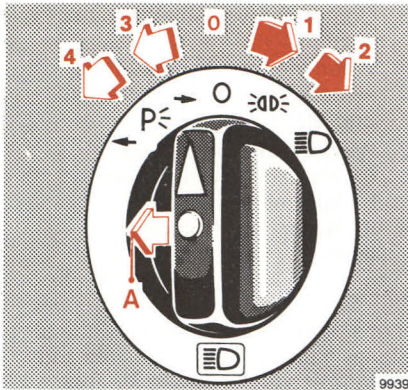

Lighting Switch

- 0 Off-position
- 1 Parking lamps (includes side marker lamps, tail lamps, license plate lamps, instrument panel lamps)
- 2 Same as pos. 1 plus headlamps
- 3 Standing lamps, right
- 4 Standing lamps, left
- A Turn to position 2 and pull out to first detent = same as position 2 plus fog lamps

Notes:

With the steering lock key removed and the driver's door open, a warning buzzer sounds if the vehicle's exterior lamps are not switched off (standing lamps excepted).

Fog lamps will only operate together with low beam headlamps. Fog lamps are turned off automatically when lighting switch is returned to off-position.

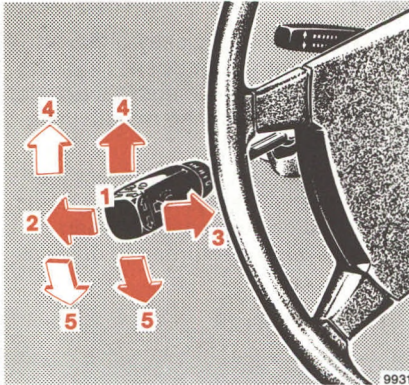

Combination Switch

- 1 Low beam (with lighting switch turned clockwise two notches)
- 2 High beam (with lighting switch turned clockwise two notches)
- 3 High beam flasher (high beam available independent of lighting switch position)
- 4 Turn signals, right
- 5 Turn signals, left

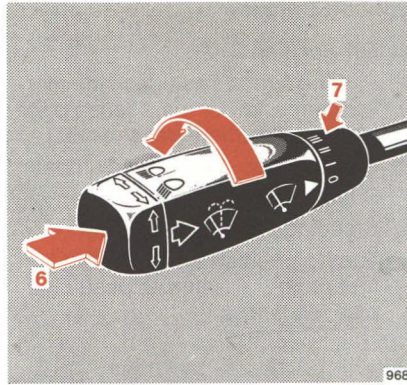

- 6 Control for windshield washer system
When the washer system is switched on, the wipers also operate.

- 7 Windshield wiper speeds
 - I Intermittent wiping
 - II Normal wiper speed
 - III High wiper speed

Hint:

If one of the turn signals fails, the turn signal indicator system flashes and sounds at a faster sequence than under normal operating conditions.

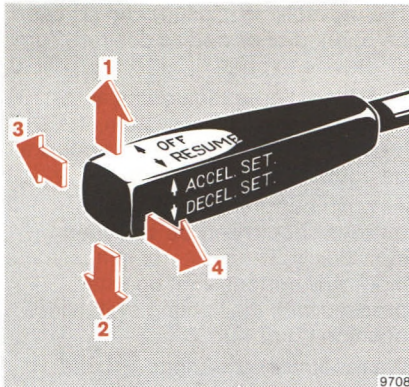

Cruise Control

Any given speed above approximately 40 km/h/25 mph can be maintained with the cruise control by operating the switch.

- 1 Setting (briefly push switch)
Accelerating (hold switch)
- 2 Setting (briefly push switch)
Decelerating (hold switch)

Normally the vehicle is accelerated to the desired speed with the accelerator. Speed is set by briefly pushing the switch to position 1 or 2. The accelerator can then be released. The speed can be increased (e.g. for

passing) by using the accelerator. As soon as the accelerator is released, the previously set speed will be resumed automatically.

If a set speed is to be increased or decreased slightly, e.g. to adapt to the traffic flow, hold switch in position 1 or 2 until the desired speed is reached. When the switch is released, the newly set speed remains.

3 Cancelling

To cancel the cruise control, briefly push lever to position 3.

When you step on the brake pedal or the vehicle speed falls below approx. 40 km/h / 25 mph, for example when driving upgrade, the cruise control will be cancelled.

4 Resume

If the lever is briefly pushed to position 4 when driving at a speed exceeding approximately 40 km/h/25 mph, the vehicle resumes the speed which was set prior to the cancellation of the cruise control. The last memorized speed is cancelled when the key in the steering lock is turned to position "1" or "0".

Note:

If the engine does not brake the vehicle sufficiently while driving on a downgrade, the speed you set on the cruise control may be exceeded and you may have to step on the brake pedal to slow down. As soon as the grade eases, the cruise controlled speed will again be maintained as long as the brakes were not previously applied.

Important:

Only use the cruise control if the traffic conditions make it advisable to travel at a steady speed.

Position "Resume" should be engaged only if the driver is fully aware of the previously set speed and wishes to resume this particular preset speed.

When driving with the cruise control, the transmission selector lever must not be shifted to position "N" as otherwise the engine will overrev.

Automatic Climate Control

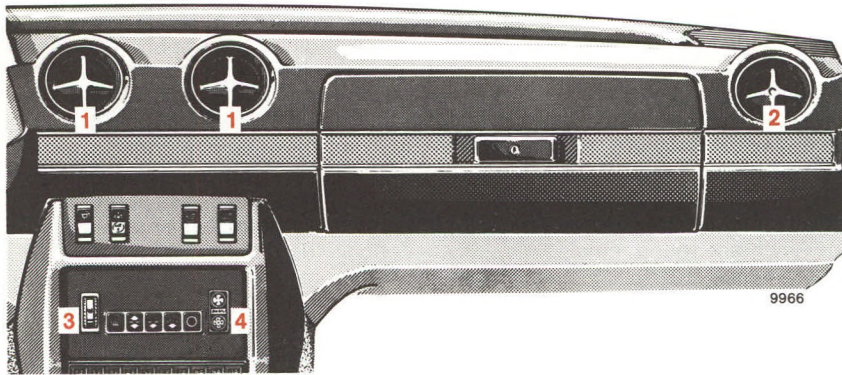

For proper operation of the climate control system, keep all windows and the sliding roof closed.



The engine must be running for the ACC unit to work.

Heating, cooling and air distribution within the vehicle's interior is automatically controlled. Furthermore, settings are available for extreme weather conditions, enabling the defogging of the windshield or air ventilation to top and bottom. This is accomplished with the temperature selector (3), the push buttons, and the fan switch (4).

The movable nozzles (1) and (2) can be opened or closed as desired. Turn clockwise to open.

For correct operation of the automatic climate control system, the movable nozzles (1) and (2) should all be open.

All push buttons and fan control buttons should only be operated individually. The indicator lamps in the individual buttons light up when pressed with the lighting switch in position (1) or (2).

We recommend settings  and  only, in connection with the desired fan setting. The following instructions explain the remaining settings.

Temperature Selection (° C)



The interior temperature can be adjusted by turning the temperature selector wheel. The selected temperature is reached as quickly as possible and maintained. A basic setting of 22° C/72° F is recommended. In order to avoid undesirable temperature fluctuations, a set temperature should be readjusted in small increments.

To override the automatic climate control, turn the temperature selector wheel to either extreme end position "MAX" or "MIN".

"MIN" = Peak cooling performance: the system operates mostly with recirculated air and a small amount of fresh air is added. If the fan control is set to "AUTOM", it will run continuously in speed No. 5.

"MAX" = Maximum heating performance. If the fan control is set to "AUTOM", it will run continuously in speed No. 5.

Fan Setting



Selection for fan settings can be made as follows:

Push upper button for maximum fan speed (6th speed).

Push lower button for minimum fan speed (1st speed).

Push middle button (spring loaded) for automatic control of air supply within 2nd through 5th fan speed range.

Setting  = Always maximum fan speed.

Functions



Off

In this setting, the fresh air supply to the interior of the car is shut off, (to prevent entrance of odors, i.e. while driving through tunnels, etc. or to prevent the entrance of water from automatic car wash). Use this setting only temporarily while driving.

Automatic Climate Control

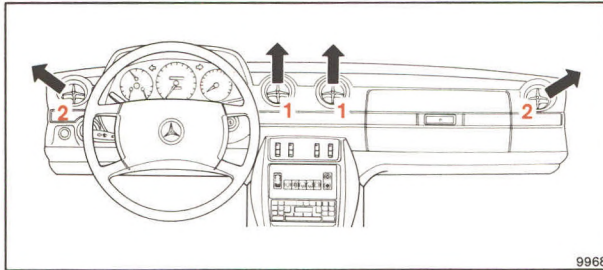

 Economy setting — Ventilation

 Normal setting — Cooling

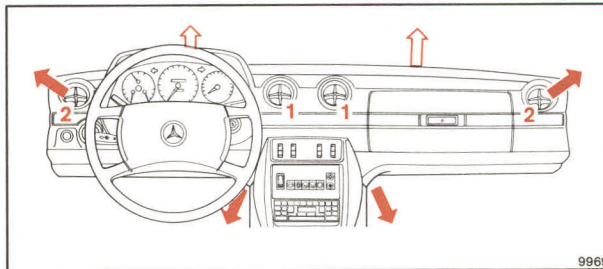

 Economy setting — Heating

 Normal setting — Heating

 EC (ECONOMY) = Economical setting; the air conditioning compressor stays off.

In any other setting, the air conditioning compressor comes on with ambient temperatures above +2° C / 36° F.

We recommend this setting to be used with cool outside temperatures so that the air conditioning compressor stays off in order to save fuel.

In the ventilation mode, air is emitted from nozzles (1) and (2).

In the heating mode, warm air is primarily supplied to the foot area. Only an amount of air sufficient to prevent fog build-up under normal climatic conditions will be channeled to the windshield and the nozzles (2). At times, air will be emitted from the nozzles (1).

With cold outside temperatures, the fresh air supply and the fan remain turned off until the engine coolant has warmed up slightly.

 Normal setting
We recommend this setting with humid and warm outside temperatures.

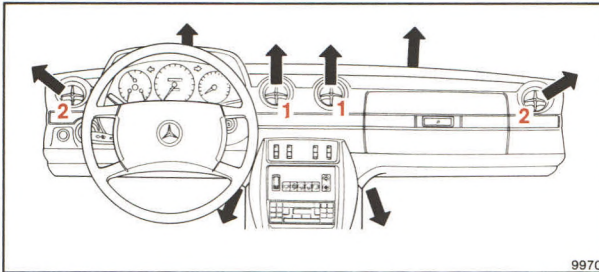

The setting  corresponds with setting  but, in addition, the air can be cooled or heated as necessary.

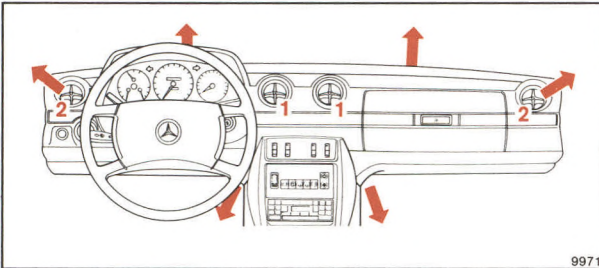

 Multi-Level ventilation — Cooling



 Multi-Level ventilation — Heating

 **Multi-Level**
 This setting is necessary for clearing a fogged windshield. As soon as possible, reset to  or .

In the heating mode, air is supplied to the windshield, foot area and to nozzles (2); in the cooling mode, additionally to nozzles (1).

In the heating mode, warm air will be emitted periodically from nozzles (1).

Automatic Climate Control

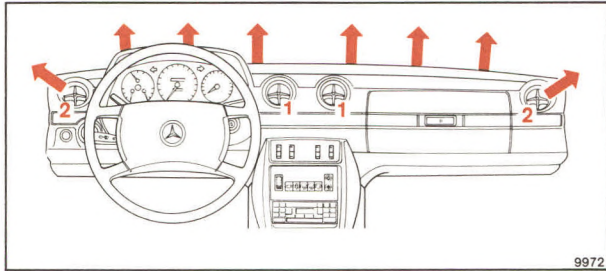

Defrosting

Defrosting

Independent of the position of the temperature selector wheel and the fan speed setting, maximum heated air will be channeled to the windshield and nozzles (2), for side window defrosting.

Note:

The air conditioner removes considerable moisture from the air during operation. It is normal if water drips on the ground through openings in the car floor.

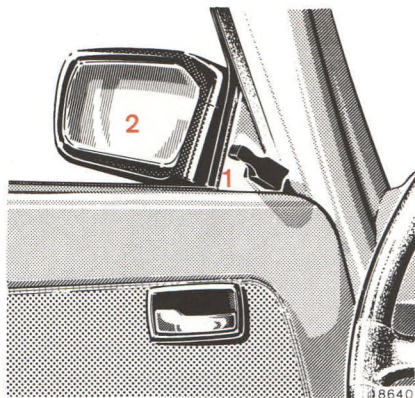

Exterior Mirrors

Driver's side:

The exterior mirror (2) can be adjusted from inside the vehicle by moving adjusting lever (1) in the desired direction.

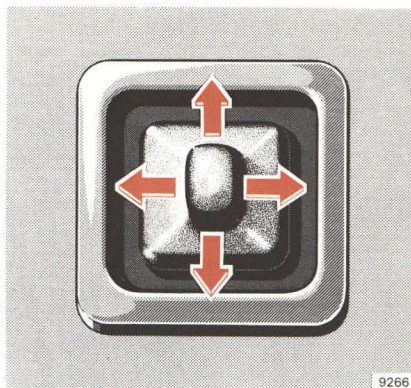

Passenger side:

Turn key in steering lock to position "1" or "2". The exterior mirror can be adjusted by means of the switch.

Note:

If the mirror housing has been forcibly removed from its normal position, it must be repositioned by applying firm pressure.

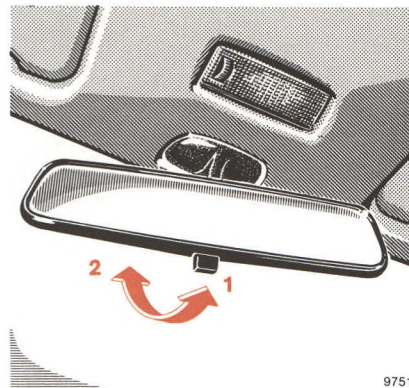

Inside Rear View Mirror

The mirror can be tilted to the anti-glare night position by means of the lever at its lower edge.

- 1 = Normal position
- 2 = Anti-glare night position.

Various Equipment

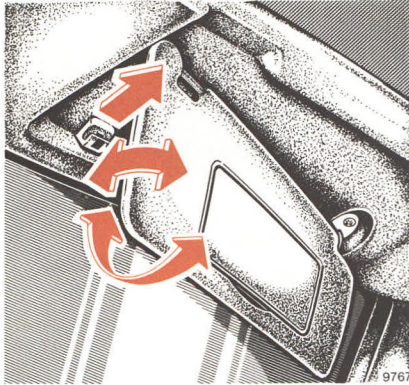

Sun Visors

Swing sun visors down to protect against sun glare.

If sunlight enters through the side window, disengage visor from inner mounting and swing to the side.

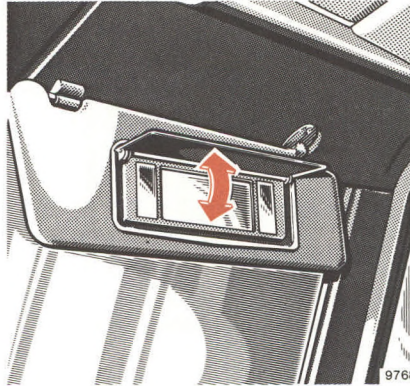

Vanity mirror:

Swing down sun visor. The lamps are switched on when the cover is opened. For this purpose the visor must be engaged in its inner mounting.

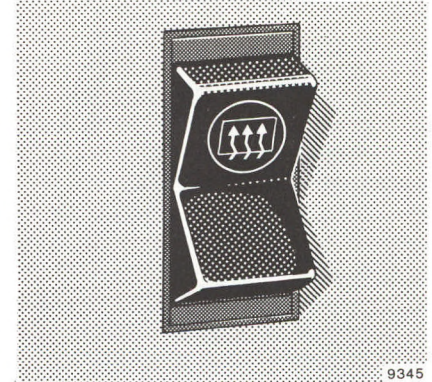

Heated Rear Window

With engine running, press symbol side of rocker switch to turn on, bottom to turn off.

When the rear window heater is turned on, the indicator lamp in the switch comes on.

A heavy load is imposed on the battery due to the high power requirement. For this reason, switch off the heated rear window as soon as it is demisted or defrosted. It is shut off automatically after a maximum of 20 minutes. Remove snow or ice from window before starting to drive.

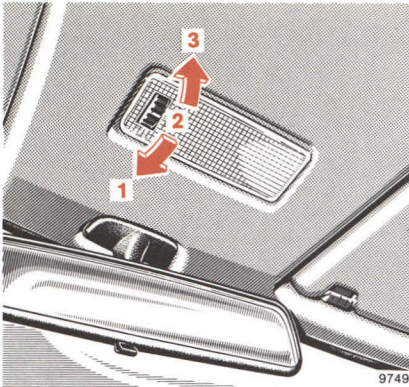

Interior Lamps

The switch for the front lamp has 3 positions.

Position 1: the lamp is switched on and off (delayed) by the front door contact switches.

Position 2: lamp switched off permanently.

Position 3: lamp switched on permanently.

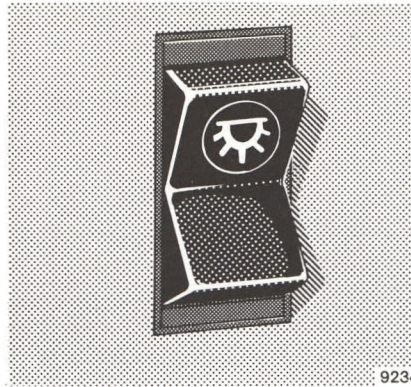

The rear courtesy lamp is switched on and off by the rear door contact switches or by the rocker switch on the instrument panel.

Shelf below Rear Window

The shelf below the rear window should not be used to carry objects. This will prevent such objects from being thrown about and injuring vehicle occupants during an accident or sudden maneuver.

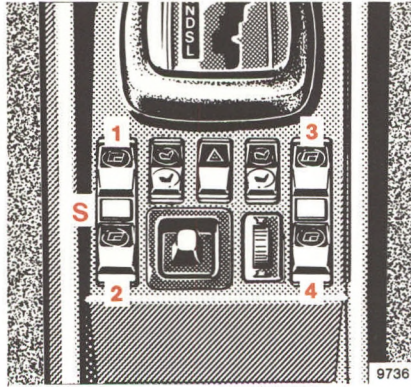

Power Windows

Switch group for power windows:

- 1 front, left
- 2 rear, left
- 3 front, right
- 4 rear, right
- S Safety switch

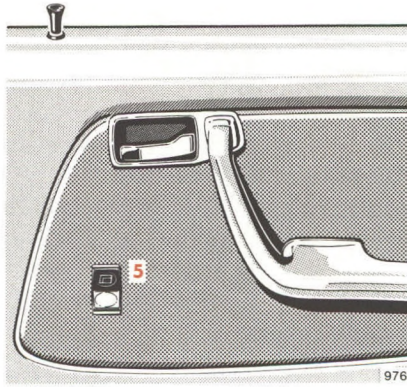

The power windows can only be operated with the steering lock in position "2". All four windows can then be operated using the switches in the center console. The rear door windows can also be operated using the switches (5) in each rear door

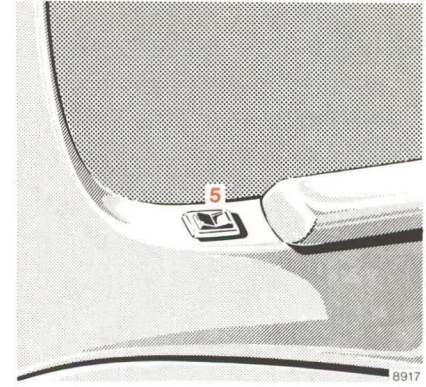

panel as long as the safety switch "S" in the center console is depressed. If the safety switch is not depressed, inadvertent operation of the rear door windows (for instance, by children) is prevented.

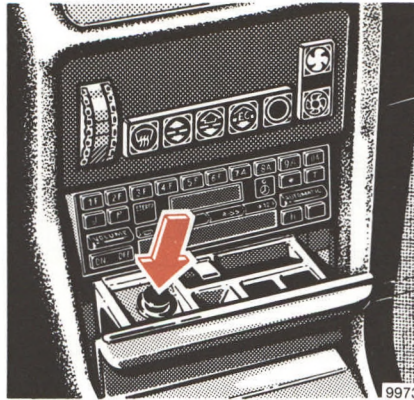

Lighter

Turn key in steering lock to position "1" or "2".

Press in lighter; it will pop out automatically when hot.

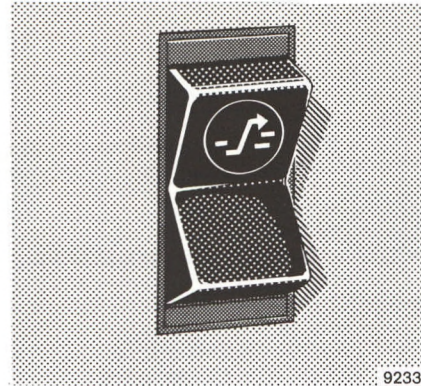

Sliding Roof

Turn key in steering lock to position "2".

Press upper end (symbol) of rocker switch to open roof, press lower end to close.

If the electric drive fails, the sliding roof can also be moved by hand. Refer to "Emergency Operation of Sliding Roof" (page 77).

Radio

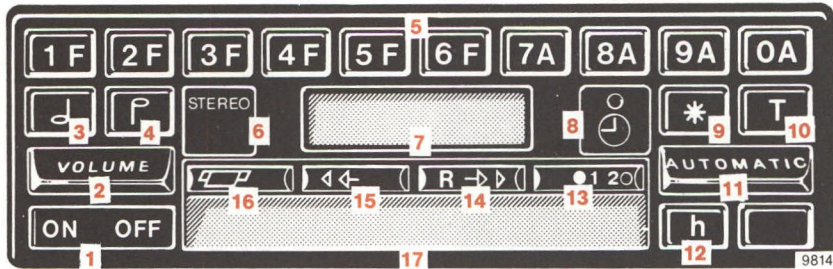

Electronic Radio

- 1 On/Off switch **ON OFF**
- 2 Volume control **VOLUME**
- 3 Bass control **B**
- 4 Treble control **T**
- 5 Push buttons for AM/FM band selection, station frequency selection, station presetting and clock setting **1 F** through **0 A**
- 6 Stereo indicator lamp **STEREO**
- 7 Digital display for station frequency, station push button number, AM/FM band **07:30** and time display
- 8 Recessed button for setting time **⌚**
- 9 Function control button *****
- 10 Timer button to control switch-on time of radio **T**
- 11 Automatic or manual search station seeker bar **AUTOMATIC**
- 12 Time display button **h**
- 13 Cassette track selector switch and track indicator **● 1 2 >**
- 14 Fast tape rewind locking button **R → >**
- 15 Fast tape forward locking button **< < <**
- 16 Cassette eject button **EJECT**
- 17 Cassette door

To turn the radio on or off, the steering lock key must be in position 1 or 2.

To turn the radio ON

Press "ON" side of **ON OFF** switch.

The radio will begin operating on the last station, volume and tone setting stored before the last turn off.

The radio can also be turned on by inserting a tape cassette through the cassette door.

To turn the radio OFF

Press the "OFF" side of the **ON OFF** switch.

Volume adjustment

To reduce volume, press volume switch **VOLUME** downward; to increase volume, press volume switch **VOLUME** upward.

A fader control, installed in the center console, allows for balancing the sound level between the front and rear speakers.

To adjust the tone characteristic

To set the radio to a “flat” tone setting (bass and treble at mid-range setting), briefly press both tone controls **[J]** **[P]** simultaneously.

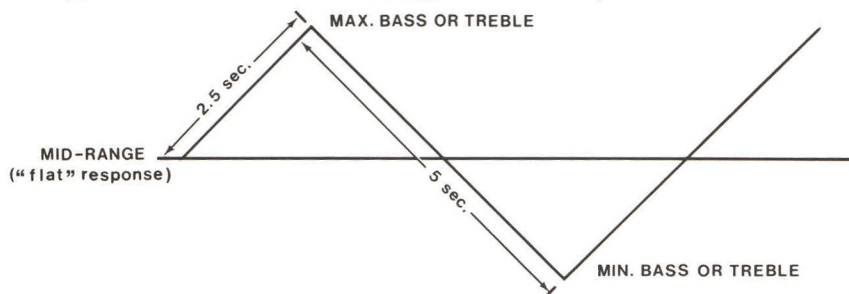

Upon pressing either tone button, the tone level for that function (either bass or treble **[P]**) will begin increasing. It stops increasing when the button is released or when the maximum tone level is reached (approx. 2.5 seconds).

After reaching the maximum tone level, the tone control will stay at that level unless the tone button is released and pressed again.

Once the tone button is pressed again the tone level will start decreasing. It will stop decreasing when the button is released or when the minimum tone level is reached (approx. 5 seconds).

After reaching the minimum tone level, the tone control will stay at that level unless the tone button is released and pressed again. After pressing the tone button again the tone level will begin to increase and the cycle is repeated.

Note: It takes approx. 5 seconds to go from minimum tone level to maximum tone level.

To select AM or FM

Press any of the buttons marked **[1F]** through **[6F]** to tune the radio to the FM band.

Press any of the buttons marked **[7A]** through **[0A]** to tune the radio to the AM band.

To tune to a station

Stations can be tuned in by using automatic search, direct frequency dialing, manual tuning, or by preset push buttons. The frequency of the station selected is indicated on the digital display.

Automatic station search

Switch to the wave band desired by pressing any of the following buttons: for FM, buttons **[1F]** through **[6F]**, for AM, buttons **[7A]** through **[0A]**.

By pressing the automatic station seeker bar **AUTOMATIC** upward the radio will search for stations in ascending frequencies, by pressing down it will do so in descending frequencies. The direction of automatic searching can be reversed by pressing the bar **AUTOMATIC** in the respective direction. In order to arrive at a desired station without stopping, the bar has to be held in the desired direction.

Radio

The radio is programmed to automatically search the entire band at three sensitivity levels. During its first sweep, only the most powerful stations received will be selected and locked in. During the next sweep, the less powerful and during the third sweep, the weak stations will also be locked in.

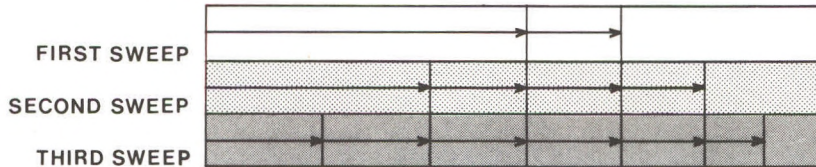

If the station seeker bar is activated within 8 seconds after the radio is tuned to a station, then the search operation will be continued at the same sensitivity level. If 8 seconds are exceeded, the radio will revert to searching only the most powerful stations.

Direct frequency dialing

In order to select a station with a known frequency, select the wave band, press the function control button ***** and then enter the frequency by pressing the corresponding push buttons.

Example:

Press any button marked
Press the function button
Enter frequency by pressing

FM 98.5 MHz

1 F through **6 F**

9 A, **8 A**, **5 F**

AM 1050 KHz

7 A through **0 A**

1 F, **0 A**, **5 F**, **0 A**

When dialing a frequency directly, the number of the push buttons is not displayed on the panel. The wave band is indicated by showing "MHz" for FM or "KHz" for AM.

Note:

All AM stations have allocated frequencies ending with a "0". All FM stations have allocated frequencies ending with an odd (uneven) digit after the decimal point.

Broadcasters sometimes may not give their exact frequency but the next closest even number.

US radio frequency ranges:
AM 540 – 1600 KHz
FM 88.1 – 107.9 MHz

Manual tuning (used to fine tune a station or for manual scanning)

After selecting the desired AM or FM wave band, press the function control button *****.

Press automatic station seeker bar **AUTOMATIC** (up or down) and hold. The frequency will increase or decrease respectively in increments of 0.1 MHz for FM or 1.0 KHz for AM. Release the button when the desired station is tuned in.

Unless the automatic station seeker bar **AUTOMATIC** is activated within 8 seconds after pressing the function control button *****, the manual tuning will automatically be deactivated.

Safety Note

To avoid distraction from the vehicle's operation and the road, it is recommended that the driver NOT perform any manual tuning operations while the vehicle is in motion. Use the automatic station search operation or preset stations instead.

Push button tuning

Six FM stations and four AM stations can be stored in memory and recalled by pressing the appropriate buttons marked **1 F** through **6 F** for FM or **7 A** through **0 A** for AM stations.

To store stations in memory

Any FM station frequency indicated on the digital display can be stored on any button marked **1 F** through **6 F** by depressing the button desired and holding it until the display has changed from the "old" setting to a "blank" and then to the new frequency to be stored.

Showing the "old" setting first allows for reconsideration of the decision to store. If it is desirable to leave the "old" frequency in memory rather than exchanging it with the "new" one, quickly release the button. The "old" frequency will remain in memory.

Any AM station can be stored similarly on any button marked **7 A** through **0 A**.

Stereo reception

The stereo indicator symbol **STEREO** lights up if a stereo program is received.

The radio is equipped with an automatic stereo/mono switch that electronically switches to mono for clear reception if a weak signal is received. A special circuit provides for a smooth change-over rather than a hard sudden switching, thereby reducing noise and interference.

The stereo indicator will remain lit even if the receiver has changed to the mono mode and will turn off at an antenna signal considered insufficient to provide acceptable reception quality.

Important! Although FM is normally static free, reception can be limited by geographic and atmospheric conditions, station strength and distance from transmitter. Buildings or other obstructions can cause momentary static, flutter or station swapping. If good reception cannot be obtained, tune to a stronger station.

Tape Cassette playback

It is recommended to use only good quality cassettes with a playback time of not more than 60 to 90 minutes (C 60) or (C 90).

To start playback, insert a cassette (tape side first, side "I" or "A" facing up) through the cassette door. Push the cassette in until it is locked in its playing position.

When the end of one playing side is reached, the unit switches automatically to reverse for playing the second track.

The tape track can be selected by depressing the cassette track switch button **1 2 3 4**. The built-in indicators show which track of the cassette the unit is playing back.

To stop playback, press the eject button **EJECT**. The unit will automatically eject the cassette and switch to radio reception.

For fast tape rewind press the fast rewind button **R >>>**. The button will lock into position until the end of the tape is reached or until the eject **EJECT** or fast forward **F <<<** button is activated.

Accordingly, for fast forward of the tape, press the fast forward button .

When the radio is turned off by pressing the "OFF" side of the **ON OFF** switch or by turning the steering lock key to the off, the cassette will automatically be ejected.

Care and maintenance

To avoid deterioration of the tone quality, occasionally clean the tape head with the special cleaner supplied in your glove compartment or available through your dealer.

To set clock

Turn steering lock key to position 1 or 2.

Briefly press recessed time set button  by using a pencil or ballpoint pen.

Enter the time at which you want to start the clock by sequentially pressing four of the top row push buttons **1F** through **0A**. The time entered will be displayed.

Note: This is a 24 hour clock and time must be entered in all four digits. A 24 hour clock counts time from midnight

to midnight, that is 24 hours. A time of 4:28 PM is indicated by this clock as 16:28 hours (12 plus 4:28 hours).

Example 1: To enter 7:30 AM, press buttons **0A**, **7A**, **3F**, **0A**

Example 2: To enter 4:28 PM, press buttons **1F**, **6F**, **2F**, **8A**

The time entered is now stored. To start the clock in accordance with a time signal or other time reference, again briefly press the recessed time set button .

A colon sign will appear between the second and third digits **07:30**, to indicate that the clock is activated. With the radio switched off, the time will be indicated on the digital display. When the radio is switched on, the digital display will indicate the frequency which the radio is tuned to.

To display time

Briefly press the call button **h**. The time will be displayed for a few seconds.

To use the timer **T**

By using the timer **T**, the radio can be automatically turned on at a preset

time. In order to set the timer **T**, the steering lock key must be in position 1 or 2. The timer **T** can only turn the radio on with the steering lock key in position 1 or 2.

Setting the timer

1. Press button **T**.
2. Enter the time for automatic turn-on by sequentially pressing four of the top row push buttons **1F** through **0A** for the 24-hour time desired.
3. Press button ***** to activate the timer. Activation of the timer is indicated by a colon between the second and third digits of the time.

Note: To activate this function each day, press buttons **T** and ***** with the ignition key in position "1" or "2". The radio will then turn on at the preset time.

Whenever you wish to verify the time at which the timer is set, press button **T**. The time will be indicated in the digital display. After a few seconds, the display will switch back to the station frequency. To change the timer to a new setting, repeat steps 1 through 3.

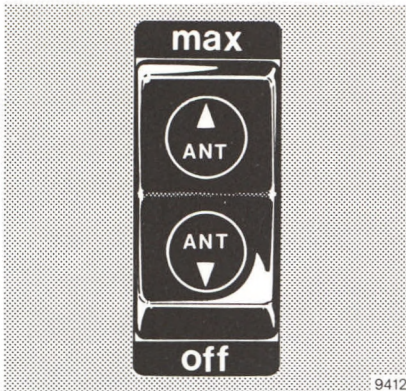

9412

Automatic Antenna

The antenna switch can be actuated with the radio switched on and the key in steering lock, positions "1" or "2".

- If the antenna switch is in the center position, the antenna extends automatically to medium height,
- if the antenna switch is engaged in the "max." position, the antenna extends fully,
- if the antenna switch is engaged in the "off" position, the antenna will not extend or will retract completely.

The height of the antenna can be adjusted to any intermediate position by actuating the antenna switch:

- If the antenna switch is in the center position, the antenna will extend to medium height. The antenna can be further extended or retracted to any height by rocking the switch (not engaging it).
- If the antenna is to be retracted, e.g. for playing cassettes, engage switch in "off" position.

When the key is turned to steering lock position "0" or the radio is turned off, the antenna will retract completely.

Driving



Hood

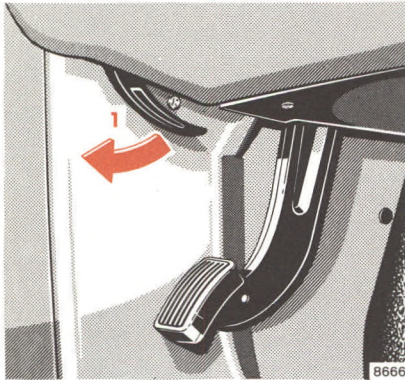

To open:

Pull hood release lever (1) under the LH side of the instrument panel to unlock the hood. The hood opens to the safety catch stop. At the same time handle (2) will pop out of the radiator grille.

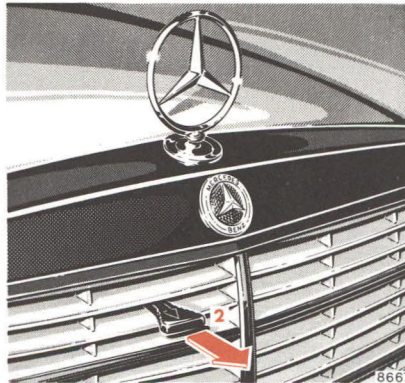

Pull handle (2) out of the radiator grille as far as the stop and lift up hood (windshield wiper arms must not be folded out).

Closing:

Close hood by depressing it firmly.

Warning!

Stay clear of moving parts when hood is open and the engine is running.

Have the following items checked regularly and prior to any long trip

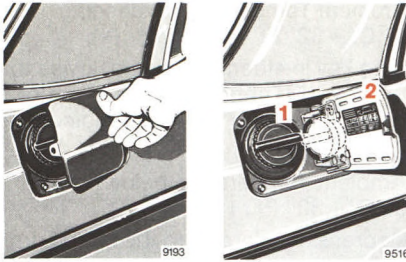

1 Fuel Supply

For winter and summer operation diesel fuels refer to "Fuels, Coolants, Lubricants, etc." and last page.

2 Tire Pressure

For tire pressure table refer to fuel filler flap or last page. Check at least every other week. For further information see "Wheels, Tires, Changing Wheels".

3 Oil/Fluid Level: Engine, Automatic Transmission

See "Checking Fuels, Coolants, Lubricants, etc.", "Fuels, Coolants, Lubricants, etc." and last page.

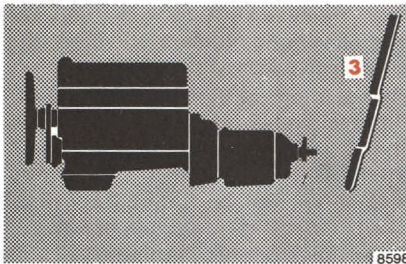

4 Coolant Level

See "Checking Fuels, Coolants, Lubricants, etc.", "Fuels, Coolants, Lubricants, etc." and last page.

5 Brake Fluid

When the minimum mark on the reservoir is reached, have the system checked (brake lining thickness, leaks).

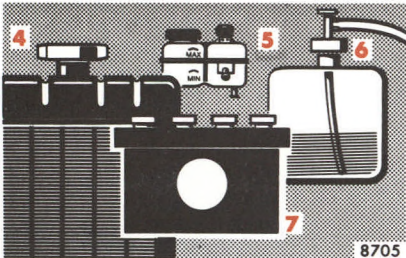

6 Windshield Washer

Replenish with windshield washer solvent (container is in the engine compartment). Add MB auto shampoo, see page 60.

7 Battery

Replenish with distilled water only. See "Electrical System".

Vehicle Lighting

Check for function and cleanliness.

Parking Brake

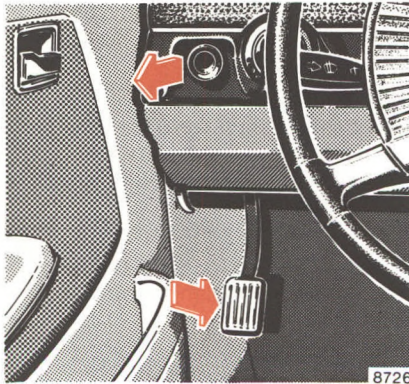

Depress parking brake pedal. When the steering lock key is in position "2", the brake warning lamp in the instrument cluster comes on.

To release, pull release button on the instrument panel. The parking brake releases in one rapid movement. The parking brake warning lamp in the instrument cluster must go out.

Starting and Turning off the Engine

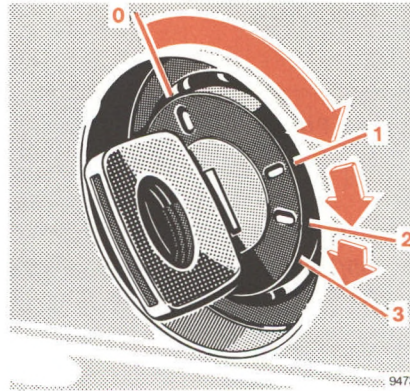

Engage parking brake before starting the engine.

Place the gear selector lever in either "P" or "N" position.

Cold Engine

Turn key in steering lock to position "2". Charge indicator and preglow indicator lamp must come on. The preglow process starts.

When the preglow indicator goes out, the engine is ready for starting.

Ambient Temperature exceeding 0° C / + 32° F:

Turn key in steering lock clockwise to the stop. Do not depress accelerator. Release key only when the engine is firing regularly.

Ambient Temperature below 0° C / + 32° F:

Depress accelerator to the floor. Turn key in steering lock clockwise to the stop. Release key only when the engine is firing regularly and back off accelerator slowly.

Do not interrupt the starting process. If the engine is very cold, it is possible that it will fail to start on subsequent attempts.

At ambient temperatures of less than -18° C / 0° F, depress accelerator three times prior to starting.

Hot Engine

Turn key in steering lock clockwise to the stop and start engine immediately without depressing the accelerator. Release the key as soon as the engine is firing regularly.

Turning off

Turn key in steering lock to position "0" and remove only when the vehicle has stopped.

Should the engine continue to operate with the key in steering lock position "0", refer to page 65.

With very high coolant temperatures (e.g. after driving on mountain passes), do not shut down the engine immediately but allow it to run at slightly increased idle speed for approximately 1 – 2 minutes.

Notes

Due to the installed starter non-repeat unit, the key in the steering lock must be returned to "0" position before making a new starting attempt.

Observe the oil pressure gauge immediately after starting. In a very cold engine the oil pressure will only rise slowly, some time after the

engine has started. Do not speed up the engine before pressure is registered on the pressure gauge.

The charge indicator lamp must go out as soon as the engine has started. If the preglow indicator fails to light up, the preglow system is defective and should be repaired at an authorized MERCEDES-BENZ dealer at the earliest possible date.

In areas where temperatures frequently drop below $-18^{\circ}\text{C}/0^{\circ}\text{F}$, we recommend that a blockheater is installed. Every MERCEDES-BENZ dealer will advise you on this subject.

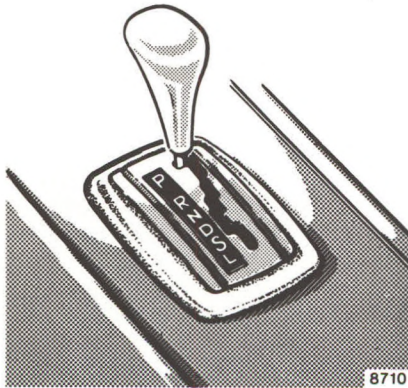

The automatic transmission simplifies the handling of the vehicle. The individual gears are shifted automatically dependent upon selector lever position, vehicle speed and accelerator position.

Hints:

When parking the vehicle or if working on the vehicle with the engine running, depress parking brake pedal and move selector lever to position "P".

Warning:

Keep driver's foot area clear at all times. Objects stored in this area may cause impairment of pedal movement.

Driving

Shift selector lever to the desired driving position only when the engine is idling and the service brake is applied. Do not release the brake until ready to drive. The vehicle may otherwise start creeping when the selector lever is in a driving position. Test the service brake shortly after driving off.

Warm up the engine smoothly. Do not place full load on the engine until the operating temperature has been reached.

When taking off on a slippery surface, do not allow one driving wheel to spin for an extended period.

Accelerator position

Partial throttle = early upshifting = normal acceleration.

Full throttle = later upshifting = maximum acceleration.

Depressing the accelerator beyond full throttle to kickdown position means downshifting to the next lower gear and thus maximum acceleration. If you ease up on the accelerator after having attained the desired speed, the transmission will shift up again.

Selector lever positions

The automatic gear shifting process can be adapted to specific operating conditions by means of the selector lever.

"P" Parking lock.

The parking lock is an additional safeguard when parking the vehicle. Engage only with the car stopped.

"R" Reverse gear.

Shift reverse gear only with the car stopped.

“N” Neutral.

No power is transmitted from the engine to the rear axle.

When the brakes are released, the vehicle can be moved freely (pushed, towed or tow-started).

Do not engage “N” when driving except when the vehicle is in danger of skidding (e.g. on icy roads, see page 56).

“D” Drive.

Automatic upshifts to top gear. Position “D” affords optimum driving characteristics under all normal operating conditions.

“S” Slope.

Upshift to 3rd gear only. Suitable for medium range up or down grades.

“L” Low.

Upshift to 2nd gear only. For driving in mountainous regions. Since transmission will not shift up any further, this gear selection will make use of the engine’s braking power.

Important!

Do not exceed the speed limits for individual gear selections, which are correspondingly indicated by marks on the speedometer.

Do not attempt downshifting to a lower gear (braking effect) unless the speedometer needle is below the speed-limit-mark of that particular gear range. Over-revving could result in damage to the engine.

On slippery road surfaces, it is not recommended to downshift in order to obtain braking action.

Maneuvering

To maneuver in tight areas, e.g. when pulling into a parking space, control the car speed by gradually releasing the service brake. Accelerate gently and do not pump the accelerator. To rock a car out of soft ground (mud or snow), alternately shift from forward to reverse, while applying partial throttle.

Trailer operation

To prevent the engine from laboring at low RPMs, do not allow the engine speed to drop too low on uphill gradients. Depending on the degree of the incline, shift selector lever to positions “S” or “L” early enough to maintain engine RPMs within best torque range.

Stopping

For brief stops, e.g. at traffic lights, leave the transmission engaged and control vehicle with the service brake.

For longer stops with the engine idling, shift into “N” or “P”.

When stopping the car on a slope, do not hold it with the accelerator, use the service brake. This avoids unnecessary transmission heat-up.

Power assistance:

When the engine is not running, both the service brake and the steering are without power assistance. Under these circumstances, a much greater effort is necessary to steer or stop the vehicle.

Tires:

Do not allow your tires to wear down too far. With less than approx. 3 mm/1/8 in of tread, the antiskid properties on a wet road fall off sharply.

Depending upon the weather and/or road pavement, the traction varies widely.

Specified tire pressures must be maintained. This applies particularly if the tires are subjected to high loads (e.g. high speeds, heavy loads, high and low ambient temperatures).

Aquaplaning:

Depending on the depth of the water layer on the road, aquaplaning may occur, even at low speeds. Avoid

track grooves in the road and apply brakes cautiously in the rain.

Tire friction:

A given speed at which a vehicle driven on dry roads can still be fully controlled must be reduced when the same vehicle is to be driven safely on a wet or icy road.

You should pay particular attention to the condition of the road as soon as the prevailing temperatures fall close to the freezing point.

If ice has formed on the road, tire traction will be substantially reduced. Under such weather conditions, drive, steer, accelerate and brake particularly carefully.

We recommended M + S radial-ply tires for the cold season. On packed snow, they can reduce your stopping distance as compared with summer tires. Stopping distance, however, is nevertheless considerably greater than when the road is wet or dry.

Brakes:

When driving down long and steep declines, relieve the brakes by shifting into "S" or "L". This prevents overheating of the brakes and reduces brake pad wear.

After hard braking it is advisable to drive on for some time so the air stream will cool down the brakes faster.

When driving in heavy rain for some time without applying the brakes, the first braking action may be somewhat reduced and increased pedal pressure may be necessary. For this reason, stay further away from a vehicle in front.

The condition of the parking brake system is checked each time the car is in the shop for maintenance.

Between maintenance checks it is a good practice to apply the parking brake once or twice while driving at approximately 50 km/h/30 mph on a dry road. Apply brake lightly until a slight drag on the wheels is felt. Keep

applying brakes for about 10 seconds while pulling release knob out, then release parking brake completely. This practice will keep the parking brake at maximum efficiency.

Warning:

The stop lamps will not come on when applying the parking brake only. Apply parking brake only when road behind vehicle is clear of traffic.

All checks and maintenance work on the brake system should be carried out by a MERCEDES-BENZ dealer.

If the parking brake is released and the brake warning lamp in the instrument cluster comes on, the brake fluid level in the reservoir is too low.

Brake pad wear or a leak in the system may be the reason for low brake fluid in the reservoir.

Have the brake system inspected at an authorized MERCEDES-BENZ dealer without delay.

Install only brake pads recommended by us. If other than recommended brake pads are installed, the braking properties of the vehicle can be affected to an extent that the safety is substantially impaired.

Brake Pad Wear Indicator Lamp

The brake pad wear indicator lamp in the instrument cluster stays on when the key in the steering lock is turned to position "2" and it must go out when the engine is running. If the indicator lamp lights up during braking, this shows that the front wheel brake pads are worn.

Have the brake system checked at an authorized MERCEDES-BENZ dealer as soon as possible.

Brake Fluid

Brake fluid should be changed once a year, preferably in spring.

Only use brake fluid recommended by us. For further information, refer to "Fuels, Coolants, Lubricants, etc."

The low brake fluid indicator lamp will come on if insufficient brake fluid is in the reservoir. (The key must be in steering lock position "2", and the parking brake released.)

When the minimum mark on the reservoir is reached, have the system checked (brake lining thickness, leaks).

Charge Indicator Lamp

Should the charge indicator lamp fail to come on prior to starting when the key is in steering lock position "2" or should it fail to go out after starting or during operation, this indicates a fault which must be repaired at an authorized MERCEDES-BENZ dealer as soon as possible.

When the charging indicator lamp glows while the engine is running, the V-belts may be loose or broken (which also makes the water pump inoperative). This may cause overheating and damage to the engine. In this case the V-belts must be tightened or replaced at once.

Fuel Reserve Warning Lamp

The fuel reserve warning lamp will come on when the key in the steering lock is turned to position "2", and will go out after the engine is running.

If the warning lamp stays on after the engine starts, or comes on while driving, it indicates that the fuel level is down to the reserve quantity.

Oil Pressure Gauge

The oil pressure at idle speed may drop to 0.3 bar/4.4 psi if the engine is at operating temperature. This will not jeopardize its operational reliability. Pressure must, however, rise immediately upon acceleration.

The oil pressure gauge will not provide early warning of low oil level. Therefore, check oil level at regular intervals with the dipstick.

Coolant Temperature Gauge

If the antifreeze mixture is good to -30°C / -22°F the boiling point of the coolant in the pressurized cooling system of your vehicle is approx. 125°C / 257°F (see also "Fuels, Coolants, Lubricants, etc.").

During severe operating conditions and stop-and-go city traffic the coolant temperature must not rise above the red marking.

Emission Control

Certain systems of the engine serve to keep the toxic components of the exhaust gases within permissible limits required by law. (Nevertheless, we urgently advise you not to let the engine run in a closed garage.) These systems, of course, will function properly only when maintained strictly according to factory specifications. Any adjustments on the engine should, therefore, be carried out only by qualified MERCEDES-BENZ technicians. The adjustments of the engine should not be altered in any way. Moreover, the specified service and maintenance jobs must be carried out regularly according to MERCEDES-BENZ servicing requirements. For details refer to the Maintenance Booklet.

Engine Oil Consumption

Engine oil consumption can only be determined after a certain mileage has been covered. During the break-in period, higher oil consumption may be noticed and is normal.

The First 1500 km/1000 Miles

The more cautiously you treat your engine during the break-in period, the more satisfied you will be with its performance later on. Therefore, drive your vehicle during the first 1500 km/1000 miles at moderate vehicle and engine speeds.

During this period, avoid heavy loads (full throttle driving) and high RPMs (no more than $\frac{2}{3}$ of maximum permissible speed in each gear).

Avoid accelerating by kickdown. It is not recommended to brake the vehicle by manually shifting to a lower gear. We recommend to select positions "S" or "L" only at moderate speeds (for hill driving).

After 1500 km/1000 miles speeds may gradually be increased to the permissible maximum.

Special Operating Conditions

Winter Driving

Have your car winterized at an authorized MERCEDES-BENZ dealer before the onset of winter.

- Engine oil change: If "year-round" multigrade engine oil is not used, be sure to use an SAE grade based on ambient temperature. For recommended engine oil viscosities refer to "Fuels, Coolants, Lubricants, etc." and last page.
- For diesel fuels, refer to page 89 and last page.
- Anticorrosion/antifreeze in the coolant: Check anticorrosion/antifreeze protection periodically. For capacity refer to "Fuels, Coolants, Lubricants, etc.".
- Additive in the windshield washer system: Add windshield washer solvent to the water in the windshield washer system.
- Test battery: Battery capacity drops with decreasing ambient temperature. A well charged battery ensures that the engine can always be started, even at low ambient temperatures.
- Tires: We recommend M + S radial tires on all wheels for the winter season. Observe permissible maximum speed for M + S radial tires and the legal speed limit.

Hints for Driving

The most important rule for slippery or icy roads is to drive sensibly and to avoid abrupt acceleration, braking and steering action. Do not use the cruise control system under such conditions.

When the vehicle is in danger of skidding, move selector lever to position "N". Try to keep the vehicle under control by means of corrective steering action.

Provided the traffic conditions will allow, only brake in a way that the wheels are locked for no more than fractions of a second as otherwise the steerability of the vehicle is lost.

Road salts and chemicals can adversely affect braking efficiency.

Increased pedal force may become necessary to produce the normal brake effect. We therefore recommend depressing the brake pedal repeatedly when traveling on salt-strewn roads at length. This can bring road salt impaired braking efficiency back to normal. A prerequisite is, however, that this is possible without endangering other drivers on the road.

If the vehicle is parked after being driven on salt treated roads, the braking efficiency should be tested as soon as possible after driving is resumed while adhering to the safety requirements.

High Altitude Correction Device

The engine is equipped with an automatic high altitude correction device.

Tire Chains

Use only tire chains that are tested and recommended by us. Any authorized MERCEDES-BENZ dealer will be glad to advise you on this subject.

Chains should only be used on the rear wheels. Adhere to the manufacturer's mounting instructions.

After driving a short distance retighten the mounted chains.

Tire chains should only be driven on snow at speeds not to exceed 50 km/h/30 mph. Remove chains as soon as possible when driving on roads without snow.

Traveling Abroad

Abroad, there is a widely-spread MERCEDES-BENZ service network at your disposal. If you travel into areas which are not listed in the index of your dealer directory, you should request pertinent information from your dealer.

Vehicle Care



A maintenance booklet is delivered with your car listing all the maintenance jobs that must be carried out after the following mileages:

Routine Maintenance

Inspection at

1300 – 1600 km/800 – 1000 miles

Lubrication Service every

8000 km/5000 miles

Maintenance Service every

24 000 km/15 000 miles

Additional Work every

48 000 km/30 000 miles

In the case of low mileage operation, the Maintenance Service must be carried out at least once every 2 years.

Engine Oil and Filter Change

Required every 8000 km/5000 miles, or a least once a year when using year-round multigrade oil; otherwise at least twice a year (spring and fall).

Under severe operating conditions or if diesel fuels with high sulphur content (in excess of 0.5 % by weight) are used, the oil and filter should be changed every 4000 km/2500 miles.

For engine oil recommendations, see page 86.

Severe Operating Conditions

In the case of severe operating conditions or heavy use mainly in city traffic or over short distances, frequent mountain driving, poor roads, dusty and muddy conditions, trailer operation, hard and sporty driving etc., it may be necessary to carry out maintenance work at shorter than normal intervals, as follows:

Engine: Oil change with filter change every 4000 km/2500 miles

Automatic transmission: Fluid change without filter change every 24 000 km/15 000 miles

Tires: Inspect

Air cleaner: Clean or replace element

Special Maintenance Measures

Brake fluid should be replaced annually, preferably in the spring.

It is recommended to use only brake fluid approved by MERCEDES-BENZ.

The coolant should be checked for sufficient protection before the start

of and during the cold season. Have the coolant (water/anticorrosion/anti-freeze mixture) replaced at least every three years (see "Fuels, Coolants, Lubricants, etc.>").

Maintenance Vouchers

Your authorized MERCEDES-BENZ dealer will certify in the maintenance booklet that all lubrication and maintenance services have been carried out at the correct intervals.

Stickers to remind you when the next lubrication service or maintenance service is due, or when the brake fluid must be changed, are provided in the middle of the maintenance booklet.

Sticker attaching points

In the frame of the driver's door:
Lubrication service and maintenance service

In the engine compartment:
Brake fluid change.

Spare Parts Service

All MERCEDES-BENZ dealers maintain a stock of original spare parts required for maintenance and repair work. In addition, strategically located parts distribution centers provide quick and reliable parts service.

More than 200 000 different spare parts, even for older models, are available.

MERCEDES-BENZ original spare parts are subjected to most severe quality inspections. Each part has been specifically developed, manufactured or selected for and adapted to MERCEDES-BENZ vehicles. Therefore, MERCEDES-BENZ original spare parts should be installed.

Cleaning and Care of the Vehicle

In operation, your vehicle is subjected to a great amount of varying external influences which, if gone unchecked, can attack the paintwork as well as the underbody and cause lasting damage.

Such damage is caused not only by extreme and varying climatic conditions, but also by air pollution, road salt, tar, gravel and stone chipping. Grease and oil, fuel, coolant, brake fluid, bird droppings, tree resins, etc. should be immediately removed to avoid paint damage. Frequent washing, however, reduces and/or eliminates the aggressiveness and potency of the above adverse influences.

More frequent washings are necessary to deal with unfavorable conditions; for example, near the ocean, in industrial areas (smoke, exhaust emissions), or during winter operation.

You should check over your vehicle from time to time for stone chipping or other damage. Any damage should be repaired as soon as possible to prevent the start of corrosion.

In doing so, do not neglect the underside of the car. A prerequisite for a thorough check is a washing of the underbody followed by a thorough inspection. Damaged areas need to be re-undercoated.

Your vehicle has been treated at the factory with a wax-base rustproofing in the body cavities which will last for the lifetime of the vehicle. Post-production treatment is neither necessary nor recommended by MERCEDES-BENZ because of the possibility of incompatibility between materials used in the production process and others applied later. After every engine cleaning you should have the engine compartment rustproofed. Before rustproofing, all control linkage bushings have to be lubricated with hydraulic oil (check with your local MERCEDES-BENZ dealership for recommended brands).

We have selected car-care products and compiled recommendations which are specially matched to our vehicles and which always reflect the

newest in technological standing. You can obtain MB car-care products at every MERCEDES-BENZ dealer.

Scratches, corrosive deposits, corrosion or damage due to negligent or incorrect care cannot always be removed with the car-care products recommended here. In such cases it is best to seek aid at your authorized MERCEDES-BENZ dealer.

The following topics deal with the cleaning and care of your vehicle and give important “how-to” information as well as references to recommended MB car-care products.

Car Washing

Before washing your vehicle, remove insect residues. The car should not be washed in the sun. Use only a mild car wash detergent, such as MB auto shampoo.

Thoroughly spray the car with a diffused jet of water. Direct only a very weak spray towards the ventilation intake. Use plenty of water and rinse the sponge and chamois frequently. Rinse with clear water and thoroughly wipe dry with a chamois. If the vehicle has been run through an automatic car wash — in particular

one of the older installations — rewipe the recessed sections provided in the tail lamps (for improved prevention of soiling) if necessary. No solvents (fuels, thinners, etc.) must be used.

In the winter, thoroughly remove all traces of road salt as soon as possible.

When washing the car underbody, do not forget to clean the inner sides of the wheels.

Tar Stains

Quickly remove tar stains before they dry and become more difficult to remove.

Window Cleaning, Wiper Blades

Use a window cleaning solution on very dirty or oil-stained windows. Clean windshield wiper blades with a clean cloth and detergent solution. Replace blades at least once or twice a year.

To assist with the removal of accumulated road film on the windshield and improve wiping ability, a cap of MB auto shampoo can be added to the 3 liter container of washer solvent.

Plastic Parts, Headliner, Rubber Parts and MB-Tex Upholstery Covers

Do not use oil or wax on these parts.

Using aftermarket seat covers or wearing clothing that have the tendency to give off coloring (e.g. when wet, etc.) may cause the upholstery (velour for example) to become permanently discolored. By lining the seats with a proper intermediate cover, contact-discoloration will be prevented.

Seat Belts

The webbing must not be treated with chemical cleaning agents. Use only clear, lukewarm water and soap. Do not dry the webbing at temperatures above 80° C/176° F or in direct sunlight. Never bleach or re-dye the webbing.

Steering Wheel, Selector Lever and Instrument Cluster

Use a gentle dish-washing detergent or mild detergent for delicate fabrics as a washing solution. Wipe with a cloth moistened in lukewarm solution. Do not use scouring agents.

Upholstery

Leather: Wipe leather upholstery with a damp cloth and dry thoroughly. Exercise particular care when cleaning perforated leather as its underside should not become wet.

Velours: Pressure marks resulting from dampness and heat may appear to be stains. Such marks can be removed by wiping with a moistened brush, ironing with a wet cloth or by treating with a dry shampoo. Do not sit on damp upholstery. Quick drying is achieved by applying hot air — for example, by using a hair dryer. If in doubt, please consult your authorized MERCEDES-BENZ dealer.

Paintwork

Do not apply wax if your car is parked in the sun or if the hood is still hot.

For maximum protection, the paintwork should be waxed approximately once every three months. Use the appropriate MERCEDES-BENZ Touch-Up Stick for quick and provisional repairs of minor paint damage.

Light Alloy Wheels

If possible, clean wheels once a week with lukewarm water and autoshampoo. Use an ample supply of water.

To remove stubborn marks, use polish or paint cleaner and apply with buffing cloth or a soft cloth.

Ornamental Moldings (Chrome-Plated, Aluminium)

For regular cleaning and care of very dirty chrome-plated parts, use a chrome cleaner.

Practical Hints



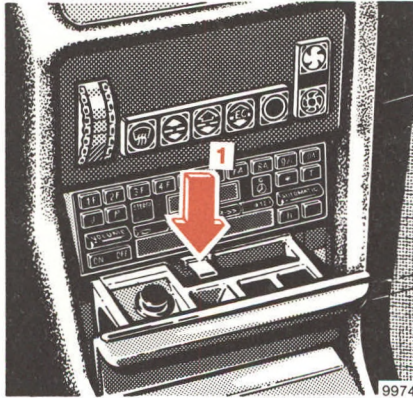

Ash trays

To remove front ash tray:
Pull ash tray out as far as possible.
Push down the spring (1) in the center and remove ash tray.

To install ash tray:
Position ash tray squarely and push in.

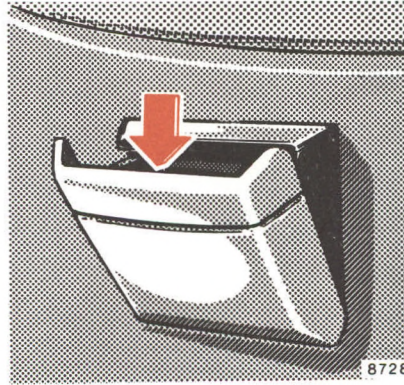

To remove rear ash tray:
Push the ash tray down while opening and remove.

To install ash tray:
Position ash tray squarely and push in.

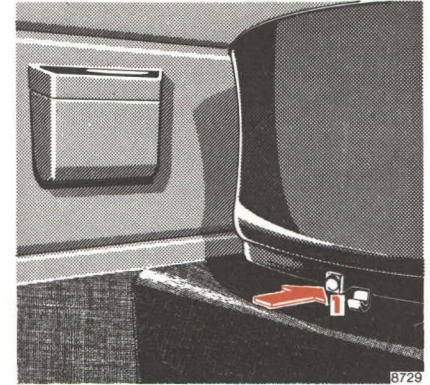

Rear Seat Cushion

Removal: Depress buttons 1 (left and right) and at the same time slightly lift up rear seat cushion at the front end (do this carefully to avoid injury). Then pull the cushion forward (Center arm rest must be folded up).

Installation: Push rear of seat cushion under seat back as far as it will go and press down on the front section until it engages.

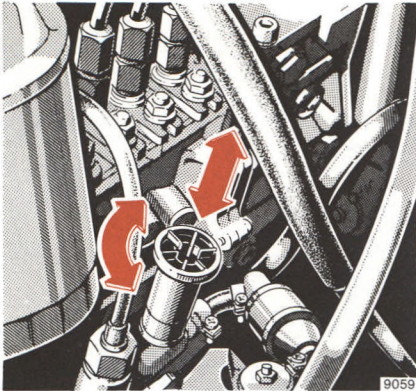

Bleeding the Fuel System

A completely bled fuel system is imperative for perfect engine operation. During operation, the system is continuously bled via the over-flow line.

The entire system must be bled manually after the fuel tank has been driven completely empty.

Note:

Disengage primer pump handle prior to operating it (turn counterclockwise). Retighten after use.

First, fill fuel tank with fuel. Then operate primer pump until the bypass valve on the injection pump opens (hissing noise).

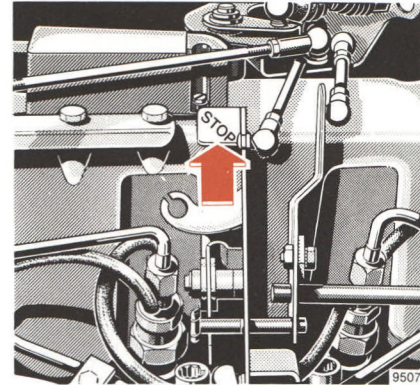

Turning off Engine Manually

If the engine continues operating in steering lock position "0", open hood and press lever marked "STOP" until the engine stops.

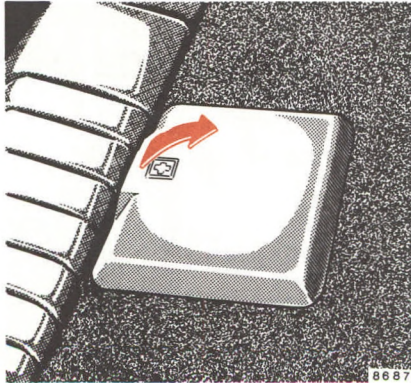

First Aid Kit

The first aid kit is stored in the hat shelf at the rear.

Luggage or Ski Racks

We recommend the use of drip rail mounted ski and roof racks. These racks do not require additional supports (suction cups or legs). Such supports may lead to marring of the paint or even denting of the roof if excessive weight is placed on the rack. Your MERCEDES-BENZ dealer can give further advice.

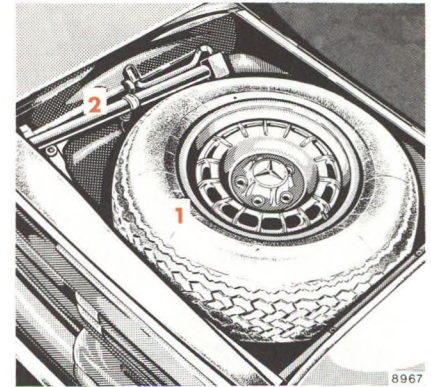

Spare Wheel, Jack, Vehicle Tool Kit

The spare wheel (1), jack (2) and the tool kit are stored in a compartment below the trunk floor. Fold back trunk floor mat and remove cover plate.

Warning!

The jack is designed exclusively for jacking up the vehicle at the jack tubes provided on either side of the vehicle. Use the jack only to lift the vehicle during a tire change. Never get beneath the vehicle while it is supported only by the jack. Jack stands must be used when working under the vehicle.

Wheels, Tires

Replace wheels or tires with the same designation, manufacturer and type as shown on the original part.

See any authorized MERCEDES-BENZ dealer for information on tested and recommended wheels and tires for summer and winter operation. They can also offer more advice concerning tire service and purchase.

Front tires should be replaced in sets. If possible, the spare tire should be used on the rear wheels. We recommend that you break in new tires for approx. 100 km/60 miles at moderate speed.

After a wheel change, it is imperative that the wheel mounting bolts be retightened after approx. 800 km/500 miles. On new vehicles retighten-

ing is carried out in the course of the 1st inspection. Retightening is also necessary when new wheels are fitted at a later date, e.g. when the spare wheels is used for the first time or when a new set of wheels with M + S tires is fitted.

For tire specifications, refer to "Technical Data".

Rotating wheels:

The wheels can be rotated according to the degree of tire wear while retaining the same sense of rotation. Rotating, however, should be carried out before the characteristic tire wear pattern (shoulder wear on front wheels and tread center wear on rear wheels) becomes visible at a mileage of 5000 – 10 000 km/3000 – 6000 miles as otherwise the driving properties deteriorate.

Slowly leaking air (e.g. due to a nail in the tire) may cause damage to the tire such as tread separation. Regular tire pressure checks at intervals of no more than 14 days are therefore essential. For the tire pressure checks, keep in mind that hot tires show higher pressure than cold tires. See tire pressure chart on last page.

Should the tire pressure decrease constantly, check whether foreign objects have penetrated the tire or if the rim or valve allows air to leak.

Thoroughly clean the inner side of the wheels any time you rotate the wheels or wash the vehicle's underside.

Dented or bent rims cause tire pressure loss and damage to the tire beads. For this reason, check rims for damage at regular intervals.

The rim flanges must be checked for wear before a tire is mounted. Remove burrs, if there are any.

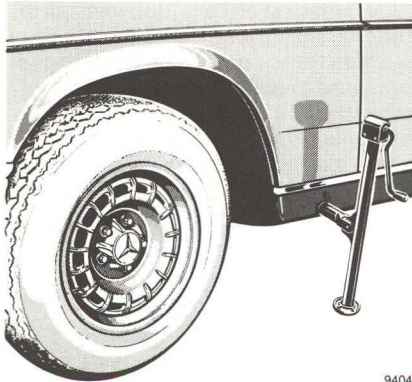

9404

Changing Wheels

1. Set parking brake.
2. Move selector lever to position "P".
3. Prevent vehicle from rolling away by blocking wheels with wheel chocks: When changing a wheel on a hill, place chocks behind each wheel of the axle opposite to the axle to be worked on; on a level road, place one chock in front and one behind of the wheel that is diagonally opposite to the wheel being changed.

4. Using the combination wrench, loosen but do not yet remove the wheel bolts.
5. Clean jack supporting tube, if necessary. (Jack tubes are behind the front wheel housings and in front of the rear wheel housings.)
6. Insert jack arm fully into tube hole up to the stop. Position the jack so that it will always be vertical as seen from the side, even on inclines. Jack up the vehicle until the wheel is clear off the ground.
7. Then unscrew wheel bolts completely. Keep bolt threads protected from dirt and sand. While removing last bolt, hold wheel against axle to avoid paint damage on rim.
8. Remove wheel.
9. Adjust the jack to allow the wheel to be slipped on without being lifted.

10. Slip on wheel and press against wheel mounting flange. Turn in wheel bolts.
To avoid paint damage, place wheel flat against hub and hold it there while installing first wheel bolt.
11. Lower car and remove jack. Tighten the five bolts evenly by tightening every other bolt until all the bolts are tight. Observe a tightening torque of 110 Nm/ 80 lb-ft.
12. Correct tire pressure.

Tire pressure

A table (see fuel filler flap or last page) lists the tire inflation pressures specified for summer and winter tires as well as for the varying operating conditions.

Important!

Tire pressure differs by approx. 0.1 bar/1.5 psi per 10° C/18° F of air temperature change. Keep this in mind when checking tire pressure inside a garage — especially in the winter.

Example:

Room temperature = approx. +20° C/ +68° F

Ambient temperature = approx. 0° C/ +32° F

Adjusted air pressure = specified air pressure + 0.2 bar/ + 3 psi.

Tire temperatures and pressure increase with the vehicle speed. Tire pressure should therefore only be corrected on cold tires. Correct tire pressure in hot tires only if pressure has dropped below the data listed in the table and the respective operating conditions are taken into consideration.

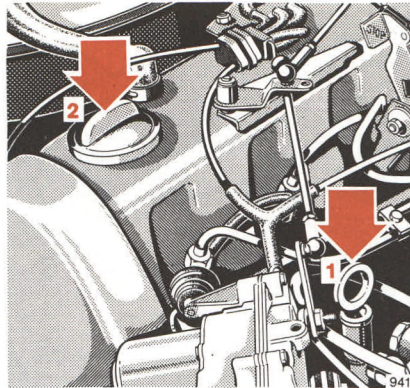

Engine Oil Level Check

- 1 Dipstick
- 2 Oil filler cap

Check engine oil level regularly or after each fuel fill-up, with the engine off and at operating temperature (engine must be at operating temperature for some time).

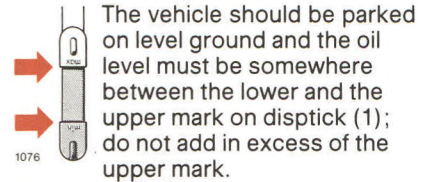

Wipe dipstick before any oil level measurement. To determine the oil level, check both sides of the dipstick. Always determine the oil level by means of the straight horizontal marking formed by the oil on one side of the dipstick.

For viscosity and capacity, see "Fuels, Coolants, Lubricants, etc." and last page.



Federal version

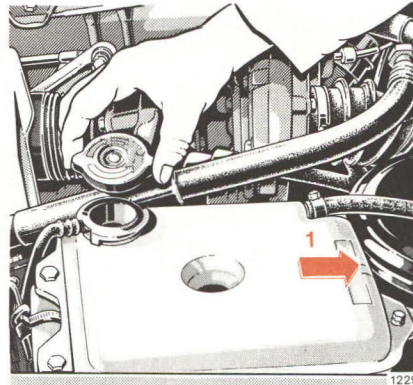

California version

Warning!

Do not remove pressure cap on coolant reservoir if engine temperature is above 90° C/194° F. Allow engine to cool down before removing cap. The coolant reservoir contains hot water and is under pressure.

Using a rag, turn cap to first notch to relieve excess pressure. If opened immediately, hot scalding fluid and steam will be blown out under pressure.

The drain plugs for the cooling system are located on the right-hand side of the engine block and the bottom of the radiator.

Checking Coolant Level

The coolant level can be checked visually at the transparent coolant reservoir.

To check the coolant level, the vehicle must be parked on level ground.

The coolant level must reach:

The marking (1, arrow) on the reservoir when the engine is cold.

Approx. 2 cm/0.8 in higher when the engine is at operating temperature.

Adding Coolant

If a small amount of coolant has to be added (due to evaporation of water), plain water can be used.

If a larger quantity of coolant has to be added, a 50/50 mixture of water and anticorrosion/antifreeze should be used.

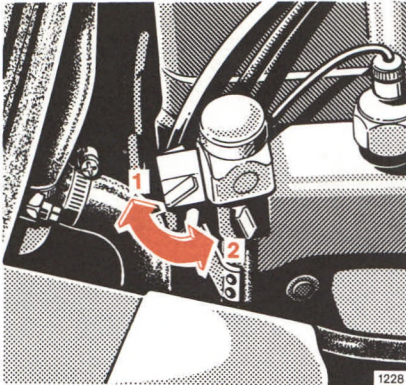

1228

Automatic Transmission Fluid Level

At regular intervals and prior to a long trip, check automatic transmission fluid level and engine oil level.

Check transmission fluid level with the engine idling, parking brake engaged and selector lever in position "P". The vehicle must be parked on level ground. Prior to the check, allow engine to idle for approx. 1 to 2 minutes.

Measure fluid level with the dipstick completely inserted and the locking lever released (1).

Extreme cleanliness must be observed! To wipe the dipstick, use a clean, lintfree cloth. To fill the transmission with fluid, pour it through a fine-mesh filter into the dipstick opening. Even the slightest impurity may cause operational troubles.

The fluid level in the transmission is dependent upon its temperature.

The maximum and minimum fluid level marks on the dipstick are applicable references only if the transmission fluid has reached its normal operating temperature of 80° C/176° F.

If the transmission fluid cools down to 20 – 30° C/68 – 86° F, which is the normal shop temperature range, then the maximum fluid level will be approximately 5 mm/0.2 in (Federal version) or 12 mm/0.5 in (California version) below the minimum mark on the dipstick. We stress this point because a fluid change is normally performed when the transmission fluid has cooled down to shop temperature.

The fluid level must not exceed the dipstick maximum mark with the fluid at operating temperature. Drain or siphon off excess fluid, if required.

Then push dipstick all the way in and swing locking lever downwards (2).

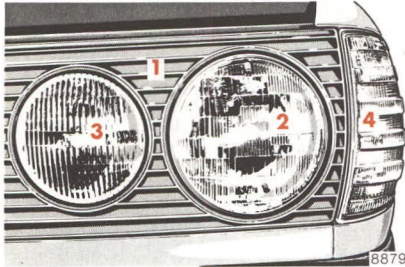

Headlamp Adjustment

Correct headlamp adjustment is extremely important. Check and readjust headlamps at regular intervals and when a lamp has been replaced.

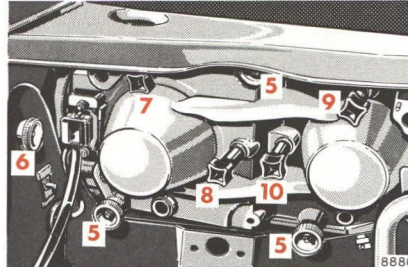

Replacing Bulbs

To remove, push the bulb in and turn to the left, then lift the bulb out.

To install, grip the bulb with a paper tissue or similar cloth, align the pins on the base of the bulb with the grooves in the bulb socket, push in lightly and turn to the right until the stop is felt.

Install only 12 volt bulbs with the specified watt rating.

Front Lamps

- 1 Cover. Remove cover (1) after backing out knurled plastic nuts located behind headlamps.

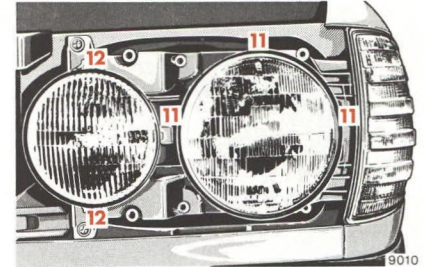

- 2 Sealed-beam unit for high and low beam (Sealed-beam/Halogen)
- 3 Fog lamp (H 3)
- 4 Turn signal, parking, side marker and standing lamp (21/5 W/ 32/3 cp)
- 5 Securing nuts for cover
- 6 Securing nuts for turn signal, parking, side marker and standing lamp
- 7 Vertical adjusting screw, sealed-beam unit
- 8 Horizontal adjusting screw, sealed-beam unit
- 9 Vertical adjusting screw, fog lamp
- 10 Horizontal adjusting screw, fog lamp

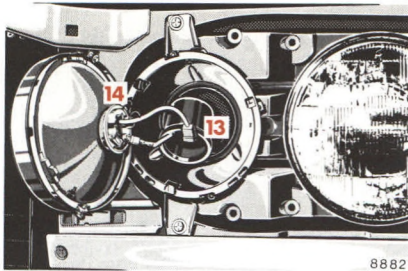

- 11 Securing screws for sealed-beam unit retaining ring. Loosen securing screws, remove retaining ring and unit. Pull off connector.
- 12 Securing screws for fog lamp retaining ring. Loosen securing screws and take out lamp body. Pull off plug (13). Disengage retaining spring and remove bulb (14).

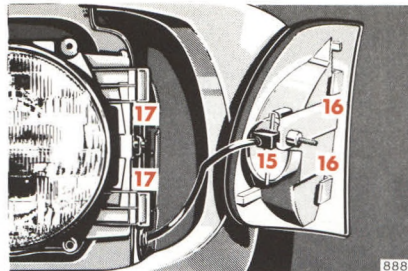

- 15 Bulb for turn signal, parking, side marker and standing lamp. Loosen fastener (6). Push lamp body forward and detach. Hold lamp holder by the wide lug and pull out. Depress bulb, turn to the left and take out. When installing the bulb holder, the lugs must engage the lamp body recesses. When installing the lamp body, never fail to engage the locating webs (16) between the retaining springs (17).

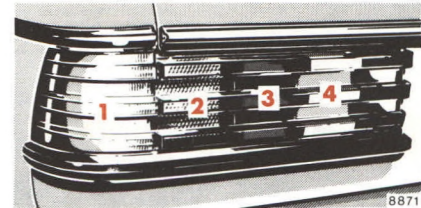

Tail Lamp Assembly

Remove both knurled nuts in the trunk and pull off lens assembly. To replace the bulbs, depress, turn left and pull out.

- 1 Turn signal lamp (21 W/32 cp)
side marker lamp (4 W/2 cp)
- 2 Tail, parking and standing lamp
(10 W/6 cp)
- 3 Stop lamp (21 W/32 cp)
- 4 Backup lamp (21 W/32 cp)

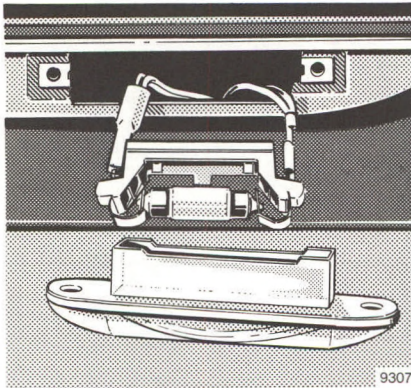

License Plate Lamps (5 W festoon lamp)

Open trunk lid, loosen both securing screws of the lamp and remove lamp. Pull out lamp holder.

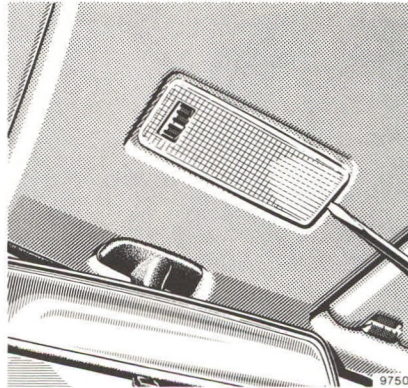

Interior Lamps (10 W festoon lamp)

To replace the bulb, lift off front lamp at RH side, pull it out and open reflector.

The same applies to the removal of the rear lamp.

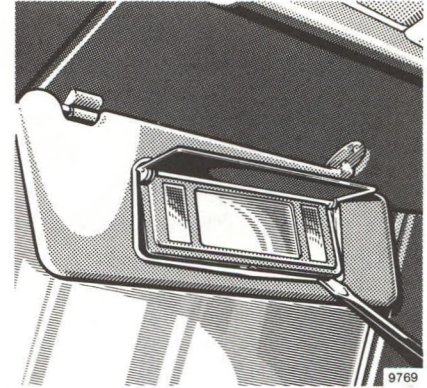

Sun Visor Lamp (5 W festoon lamp)

To replace a bulb, pry off the cover by inserting a screwdriver in the left and right slots located on the lower edge.

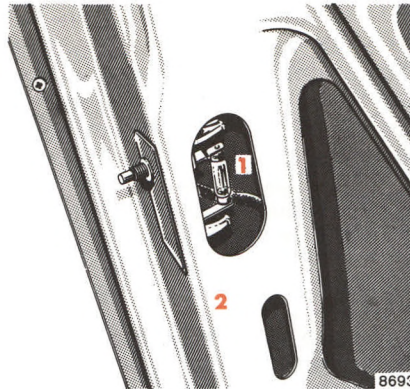

Trunk Lamp (10 W festoon lamp)

The bulb (1) is easily accessible when the trunk lid (2) is opened.



Glove Compartment Lamp
(5 W festoon lamp)

To replace the bulb, pull out lamp.

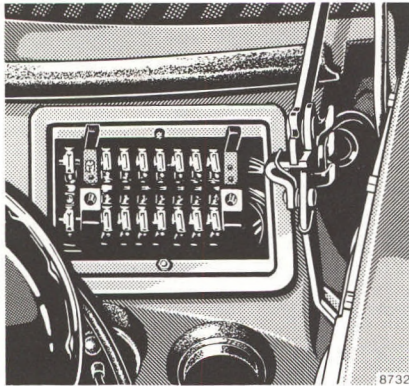

Fuses

The fuse box is located in the engine compartment.

A summary of the protected equipment is printed in the fuse box cover.

Fuse arrangement in the box — starting at engine side, proceeding from inside to outside — upper row: odd numbers

1, 3, 5 etc. up to 13;

lower row: even numbers

2, 4, 6 etc. up to 14.

Fuses must be replaced, not repaired or bridged.

Spare fuses are stored in the fuse box (observe amperage and color code).

Determine the cause of a short prior to replacing a burned-out fuse.

After replacing a fuse, screw on the fuse box cover firmly to prevent cold air leaks into the vehicle.

Battery

Check the fluid level in the cells from outside approximately every 4 weeks, and more often in summer and in hot zones.

The fluid level must be between the lower and the upper markings.

Refill battery only with distilled water. Do not use metal funnels or push through the overfill-protection diaphragms in filler holes.

The battery is completely filled when the water stops draining through the overfill-protection diaphragm.

To check the battery charge with a hydrometer, push its tip through the overfill-protection diaphragm and take the electrolyte sample.

Coat battery terminal clamps with acidproof grease. Keep battery clean and dry.

The service life of the battery is also dependent on its condition of charge. It must be maintained sufficiently charged for the battery to last an optimum length of time.

Therefore, we recommend that you have the battery charge checked frequently if you use the vehicle mostly for short distance trips, or if it is not used for long periods of time.

Only charge battery with a battery charger when it is disconnected from the vehicle electrical circuit.

Electrical System

Warning!

Battery fluid contains sulfuric acid. Do not allow this fluid to come in contact with eyes, skin, or clothing.

In case it does, immediately flush affected area with water; if necessary seek medical help.

A battery will also produce hydrogen gas, which is flammable and explosive. Keep flames or sparks away from battery, i.e. improper connection of jumper cables, cigarette smoking, etc. .

While the engine is running the battery terminal clamps must not be loosened or detached as otherwise the alternator and other electronic units would be damaged.

Only tow vehicle with the battery connected.

Emergency Operation of Sliding Roof

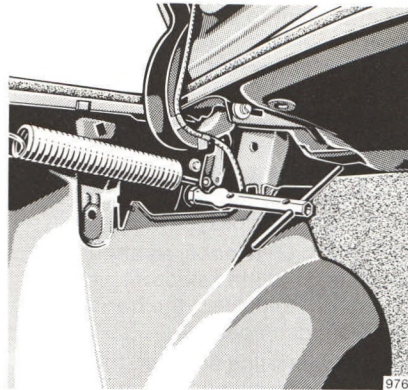

The sliding roof can be opened or closed manually should an electrical malfunction occur.

Remove small access plug in left side-panel of trunk. Insert socket wrench (from tool kit) through opening in panel and place on the hex-drive on the electric motor. Turn socket wrench as desired to open or close roof.

To close the sliding roof

Sedan: Turn wrench counterclockwise.

Coupé: Turn wrench clockwise.

Unlocking of the Filler Flap

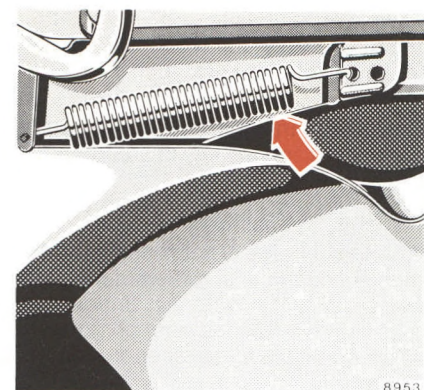

If the central locking system does not release the fuel filler flap automatically, pull down right trunk panel slightly and pull back the connecting rod between the vacuum element and door tab.

Towing eyes are situated underneath the front and rear end on the RH side. Use a solid towing link such as a towbar.

Only tow-start vehicle with the battery connected and the key in steering lock position "2".

Warning:

When the engine is not running, both the service brake and the steering are without power assistance. Under these circumstances, a much greater effort is necessary to steer or stop the vehicle.

Emergency Engine Start (Tow starting)

Shift selector lever to position "N". Turn key in steering lock to position "2" and have vehicle towed.

After attaining a towing speed of 30 km/h/18 mph (with cold transmission) or 50 km/h/30 mph (with warm transmission), shift selector lever to position "S" to tow-start the engine. Depress accelerator fully. As soon as the engine has started, release accelerator and return selector lever to "N" immediately.

It is important to allow the engine to idle for at least 1 minute before starting off because the preglowing process starts when the key is in steering lock position "2" and is not immediately disrupted after the engine has been tow-started. During this time the preglowing process is cut out automatically.

If the engine has not fired after a few seconds, shift the selector lever from "S" to "N" to protect the transmission from damage.

For a new starting attempt, tow-start the vehicle for some time again with the selector lever in position "N" and repeat the starting procedure.

The same method can be used to start the engine in emergencies when rolling downhill.

Towing a Vehicle

The vehicle may be towed with all of the wheels on the ground and the selector lever in position "N" for distances up to 120 km / 75 miles and at a speed not to exceed 50 km/h/ 30 mph.

To positively avoid a possibility of damage to the transmission, however, we recommend to disconnect the drive shaft at the rear axle drive flange on any towing beyond a short tow to a nearby garage.

For towing with front wheels lifted, attach T-hooks to the tie-down slots in the frame. Position a 4 ft long, 4 in x 4 in piece of wood under the radiator support. Position towbar in front of the 4 x 4. Attach safety chains to the lower control arms, inboard of springs.

Towing with the rear wheels lifted is preferred. Attach T-hooks to the tie-down slots. Position a 4 ft long, 4 in x 4 in piece of wood with spacer blocks under the frame extensions. Position the towbar against the bumper. Attach safety chains.

If the battery is discharged the engine can be started with jumper cables (minimum cable cross section is 25 mm²) and the (12 V) battery of another vehicle. Proceed as follows:

1. Turn key to steering lock position "0".
2. First connect jumper cables to the positive battery terminals and then to the negative terminals.
3. Start and run engine of jumper vehicle at high idle.

4. Start engine of the disabled vehicle in the usual manner.
5. After the engine has started, first remove jumper cables from the negative battery terminals and then from the positive terminals.

Instructions:

A discharged battery can freeze at approx. $-10^{\circ}\text{C} / +14^{\circ}\text{F}$. In all cases it must be thawed out before jumper cables are used.

Never lean over batteries while jump starting.

Warning!

Battery fluid contains sulfuric acid. Do not allow this fluid to come in contact with eyes, skin, or clothing. In case it does, immediately flush affected area with water, if necessary seek medical help.

A battery will also produce hydrogen gas, which is flammable and explosive. Keep flames or sparks away from battery, i.e. improper connection of jumper cables, cigarette smoking, etc. .

Technical Data
Fuels Coolants
Lubricants etc.



Identification Plates

When ordering spare parts, please quote chassis and engine numbers.



- 1 Certification Tag
(left door pillar)
- 2 Identification Tag
(left window post)

- 3 Chassis No.
- 4 Engine No.
- 5 Emission Control Tag

- 6 Body No. and Paintwork No.
- 7 Information Tag
California version
Vacuum line routing
for emission control system
- 8 Emission Control Tag
Catalyst Information

Vehicle Data Cards

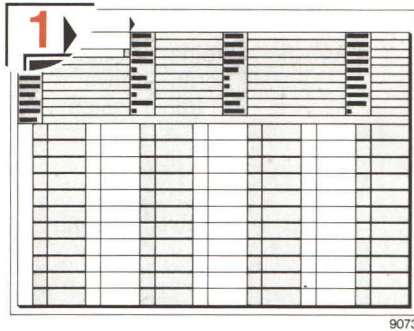

The vehicle data cards bear all the important data relating to your vehicle.

Data card No. 1 bears the key number and should never be left in the vehicle. Submit this card to your authorized MERCEDES-BENZ dealer to request a replacement key in case of loss.

Data card No. 2 bears no key data and is kept in the Maintenance Booklet. Presenting this card to the dealer will facilitate the processing of the order.

Warranty Coverage

Your car is covered under the terms of the "warranties" printed in the Owner's Service and Warranty Policy Booklet and your dealer will exchange or repair any defective parts in accordance with the terms of the following warranties:

1. New vehicle limited warranty
2. Emission systems warranty
3. Emission performance warranty
4. California emission control systems warranty (state of California only unless purchased optionally for diesel models).

Loss of Owner's Service and Warranty Policy

Should you lose your Owner's Service and Warranty Policy Booklet, have your local MB dealer arrange for a replacement. It will be mailed to you.

Technical Data

Type	300 D-TURBO DIESEL (123.133) ¹ 300 CD-TURBO DIESEL (123.153) ¹
------------	---

Engine

Engine type	617.952
Work cycle	Diesel four stroke
No. of cylinders	5
Bore	90.9 mm/3.58 in
Stroke	92.4 mm/3.64 in
Total piston displacement	2998 cm ³ / 183.0 in ³
Compression ratio	21.5
Output acc. to SAE	
Federal version	92 kW/4350 rpm/ 123 net-bhp/4350 rpm
California version	88 kW/4350 rpm/ 118 net-bhp/4350 rpm
Valve clearance } Intake	0.10 mm/0.004 in
(cold engine) } Exhaust	0.35 mm/0.014 in
Injection order	1-2-4-5-3
V-belts:	
Water pump — fan — alterna- tor: 2 V-belts	9.5 × 1035 mm
Power steering	12.5 × 1145 mm
Air conditioning	12.5 × 925 mm

Transmission

Design	Automatic four-speed torque-converter transmission
--------------	--

Steering System

Design	Power steering
--------------	----------------

Rims — Tires

Rims (forged light alloy rims) .	6 J × 14 H 2
Summer tires:	
Radial-ply tires	195/70 R 14 90 S
Winter tires:	
Radial-ply tires	195/70 R 14 90 Q M + S 195/70 R 14 90 T M + S

Electrical System

Alternator	14 V/65 A
Starter motor	12 V/2.3 kW
Battery	12 V/92 Ah

¹ The quoted data apply only to the standard vehicle. See an authorized MERCEDES-BENZ dealer for the corresponding data of all special bodies and special equipment.

Main Dimensions 300 D-TURBO DIESEL

Overall vehicle length	4848 mm/ 190.9 in
Overall vehicle width	1786 mm/ 70.3 in
Overall height	1438 mm/ 56.6 in
Wheel base	2795 mm/ 110.0 in
Track, front	1488 mm/ 58.6 in
Track, rear	1446 mm/ 56.9 in

Main Dimensions 300 CD-TURBO DIESEL

Overall vehicle length	4763 mm/ 187.5 in
Overall vehicle width	1786 mm/ 70.3 in
Overall height	1395 mm/ 54.9 in
Wheel base	2710 mm/ 106.7 in
Track, front	1488 mm/ 58.6 in
Track, rear	1446 mm/ 56.9 in

Weights See certification tag



Fuels Coolants Lubricants etc. Capacities

Vehicle components and their respective lubricants must match.

Therefore use only brands tested and recommended by us.

Inquire at your authorized MERCEDES-BENZ dealer.

		Capacity	Fuels, coolants, lubricants, etc.
Total oil capacity in case of engine oil and filter change		8.0 l/8.5 US qt	<p>Recommended engine oil</p> <p>9450</p>
Automatic transmission	Federal version	Initial fill: 7.3 l/7.7 US qt Fluid change: 6.2 l/6.6 US qt	Automatic transmission fluid for automatic transmission ²
	California version	Initial fill: 7.1 l/7.5 US qt Fluid change: 6.0 l/6.3 US qt	

¹ SAE 40 may be used if ambient temperatures constantly exceed +30° C/ +86° F.

² Any authorized MERCEDES-BENZ dealer will advise you on recommended brands.

Fuels Coolants Lubricants etc. Capacities

	Capacity	Fuels, coolants, lubricants, etc.
Rear axle	1.0 l/1.1 US qt	Hypoid gear oil SAE 90, 85 W 90 ¹
Accelerator control linkage		Hydraulic fluid
Power steering	1.4 l/1.5 US qt	Automatic transmission fluid for power steering ¹
Front wheel hubs	approx. 60 g each/2.1 oz each	High temperature roller bearing grease
Grease nipples		Multipurpose or lubrication grease
Door locks		Powdered graphite
Battery terminals		Bosch special grease
Brake reservoir	approximately 0.5 l/0.5 US qt	Brake fluid ¹
Windshield washer system	approximately 3.0 l/3.2 US qt	Windshield washer solvent
Fuel tank including a reserve of	approximately 80 l/21.1 US gal approximately 10.5 l/2.8 US gal	Diesel fuels acc. to ASTM D 975 grades 1 and 2 as well as VV-F-800 a grades 1 and 2
Cooling system	12.5 l/13.2 US qt	Coolant ¹

¹ Any authorized MERCEDES-BENZ dealer will advise you on recommended brands.

Engine Oils

Engine oils are specifically tested for their suitability in our engines. Therefore, use only engine oils recommended by us. Information on recommended brands is available at any authorized MERCEDES-BENZ dealer.

On a new vehicle, the engine is filled with break-in oil in the factory. This oil is specially developed for the specific operating conditions during the first 1300 – 1600 km/800 – 1000 miles.

A recommended engine oil may be used for topping up if the oil level drops below the dipstick minimum mark prior to the first service 1300 – 1600 km/800 – 1000 miles.

Brake Fluid

During the course of the operation of the vehicle, the boiling point of the brake fluid is continuously reduced through the absorption of moisture from the atmosphere. Under extremely hard operating conditions, this moisture content can lead to the formation of vapor in the system, thus reducing the system's efficiency. The brake fluid must therefore be replaced annually, preferably in the spring. It is recommended to use only brake fluid approved by MERCEDES-BENZ.

Your MERCEDES-BENZ dealer will provide you with additional information.

Diesel Fuels

Use only commercially available vehicular diesel fuels No. 2 or No. 1 (ASTM D 975 No. 2-D or No. 1-D).

Caution!

Diesel Fuel Additives in Vehicles Certified for California Operation

Beginning with 1985 models, this vehicle with California-Version Diesel Engine is equipped with a Trap Oxidizer. If you use non-approved fuel additives, the Trap Oxidizer could be damaged, resulting in severe engine power loss and expensive repairs, not covered under the new vehicle warranty.

See your authorized MERCEDES-BENZ dealer to find out if a list of approved additives is available.

Change engine oil in compliance with section "Engine Oil Change and Oil Filter Service" if diesel fuels are used whose sulphur content exceeds 0.5 % by weight. Marine diesel fuel, heating oil or the like must not be used.

At very low temperatures the fluidity of No. 2-D diesel fuel may become insufficient due to paraffin separation.

To avoid malfunctions, No. 2-D diesel fuel of a lowered cloud point is marketed during the cold season.

At temperatures below 0° C/ +32° F use winterized or No. 1 diesel fuel only. If not available, a certain quantity of kerosene may be added. Mixing only to be done within the cars' fuel tank. Kerosene has to be filled in before the diesel fuel.

Engine power may drop according to the proportion of kerosene. For this reason, keep percentage of kerosene added to the minimum necessitated by the ambient temperature.

The following table can be used as a reference, if adding of kerosene becomes necessary. The mixing ratios shown refer to the total mixture.

Ambient temperature	No. 2 Diesel Fuel %	Kerosene %
0° C to -10° C/ +32° F to +14° F	70	30
below -10° C/ +14° F	50	50

Even in extreme climatic conditions, the maximum mixture ratio should not exceed 50 %.

Adding of kerosene to No. 1-D diesel fuel is not recommended even at low temperatures.

Warning!

Always follow basic safety rules when working with any combustible material. Do not fill the fuel tank or mix diesel fuel and kerosene when smoking, near an open flame or while the vehicle's engine is running. An explosion or fire can result.

Coolants

The engine coolant is a mixture of water and anticorrosion/antifreeze, which provides:

- corrosion protection
- freeze protection
- boiling protection (by increasing the boiling point).

The cooling system was filled at the factory with a coolant providing freeze protection to $-30^{\circ}\text{C} / -22^{\circ}\text{F}$ and corrosion protection. The red area of the temperature gauge is matched to the heating properties of this coolant solution.

The coolant solution must be used year round to provide the necessary corrosion protection and increase in the boil-over protection. You should have it replaced every 3 years.

To provide the important corrosion protection, the solution must be at least 33 % anticorrosion/antifreeze (equals a freeze protection to $-20^{\circ}\text{C} / -4^{\circ}\text{F}$). If you use a solution that is more than 55 % anticorrosion/antifreeze (freeze protection to

$-40^{\circ}\text{C} / -40^{\circ}\text{F}$), the engine temperature will increase due to the lower heat transfer capability of the solution. Therefore, do not use more than this amount of anticorrosion/antifreeze.

If the coolant level is low, water and M-B anticorrosion/antifreeze should be used to bring it up to the proper level (have cooling system checked for signs of leakage).

The water in the cooling system must meet minimum requirements, which are usually satisfied by normal drinking water. If you are not sure about the water quality, consult your authorized MERCEDES-BENZ dealer.

Anticorrosion/antifreeze

Your vehicle contains a number of aluminium parts. The use of aluminium components in motor vehicle engines necessitates that anticorrosion/antifreeze/coolant used in such engines be specifically formulated to protect the aluminium parts. (Failure to use such anticorrosion/antifreeze/coolant may result in a significantly shortened service life.)

While there may be a number of anti-corrosion/antifreeze/coolants available which will provide the requisite protection, all such products have not been tested for MERCEDES-BENZ vehicles. The following product, however, is recommended for use in your car: MERCEDES-BENZ Anticorrosion/Antifreeze Agent.

Before the start of the winter season (or once a year in the hot southern regions), you should have the anticorrosion/antifreeze concentration checked. The coolant is also regularly checked each time you bring your vehicle to your authorized MERCEDES-BENZ dealer for maintenance service.

Freeze protection	Anticorrosion/antifreeze
-30°C } -22°F }	5.50 l/5.8 US qt
-40°C } -40°F }	6.50 l/6.9 US qt

Customers who are interested in ordering service literature for their vehicles are advised to contact our subsidiaries in the U.S. or Canada at the following addresses, respectively

for U.S.A.: Mercedes-Benz of N.A. Inc.
One Mercedes Drive
P.O. Box 350
Montvale, New Jersey 07645
Att: Technical Publications
Tel: (201) 573-0600

for Canada: Mercedes-Benz of Canada
849 Eglinton Ave., East
Toronto 17, Ont., Canada
Att: Service Department
Tel: 416-425-3550

The above companies will be happy to handle any such requests from customers.

We consider this to be the best way obtaining accurate information for your vehicle.

This has been prepared as required of all manufacturers of passenger cars under Title 49, Code of U. S. Federal Regulations, Part 575 pursuant to the "National Traffic and Motor Vehicle Safety Act of 1966".

Uniform Tire Quality Grading

Relevant tire grade information on tire flanks.

All passenger car tires must conform to federal safety requirements in addition to these grades.

Traction "A", "B", "C"

The traction grades, from highest to lowest, are "A", "B" and "C" and they represent the tire's ability to stop on wet pavement as measured under controlled conditions on specified government test surfaces of asphalt and concrete. A tire marked "C" may have poor traction performance.

Warning: The traction grade assigned to this tire is based on braking (straightahead) traction tests and does not include cornering (turning) traction.

Temperature "A", "B", "C"

The temperature grades of "A" (the highest), "B" and "C" representing the tire's resistance to the generation of heat and its ability to dissipate heat when tested under controlled conditions on a specified indoor laboratory test wheel. Sustained high temperature can cause the material of the tire to degenerate and reduce tire life, and excessive temperature can lead to sudden tire failure. The grade "C" corresponds to a level of performance which all passenger car tires must meet under the Federal Motor Vehicle Safety Standard No. 109. Grades "B" and "A" represent higher levels of performance on the laboratory test wheel than the minimum required by law. Warning: The temperature grade for this tire is established for a tire that is properly inflated and not overloaded. Excessive speed, underinflation, or excessive loading, either separately or in combination, can cause heat buildup and possible tire failure.

Vehicle Stopping Distance

This figure indicates braking performance that can be met or exceeded by the vehicles to which it applies, under different conditions of loading and with partial failures of the braking system. The information presented represents results obtainable by skilled drivers under controlled road and vehicle conditions, and the information may not be correct under other conditions.

Description of the vehicles to which this table applies: **300 D-TURBO DIESEL, 300 CD-TURBO DIESEL**

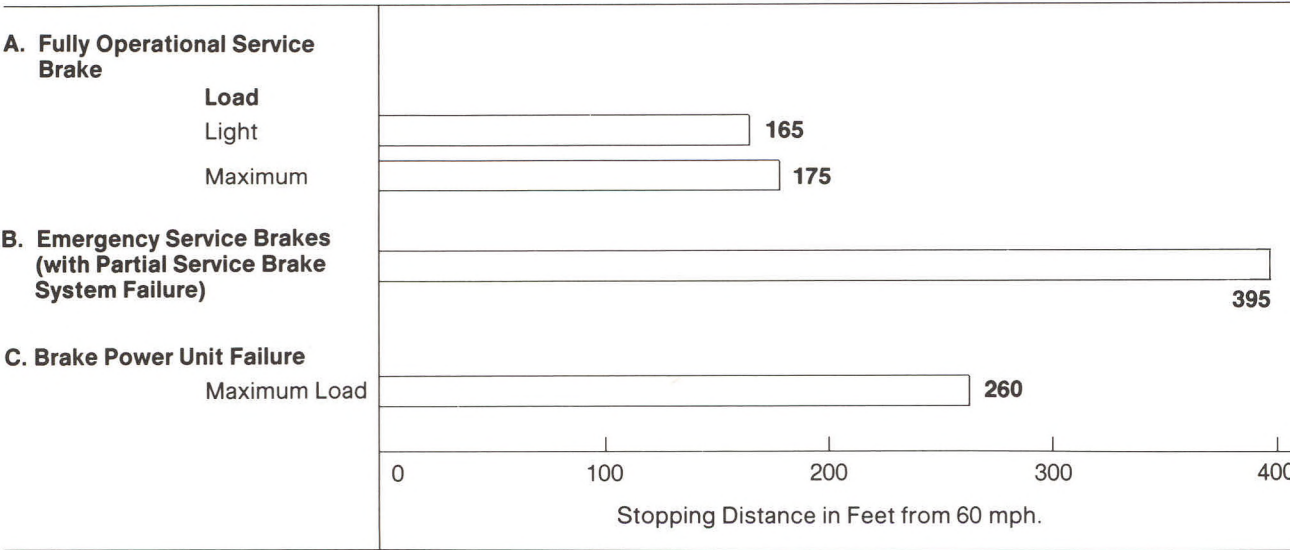

Printed in Germany

We reserve the right to modify the technical details of the vehicle as given in the data and illustrations of this Owner's Manual (s.e.e.o). Reprinting, translation and copying, even of excerpts, is not permitted without our prior authorization in writing

ZKD/9.84 15/PVL

What You Should Know at the Gas Station

- **Fuel:** Diesel fuels acc. to ASTM D 975, grades 1 and 2 as well as VV-F-800a grades 1 and 2. See page 89.
Fuel tank capacity approx. 80 l/21.1 US gal, this includes approx. 10.5 l/2.8 US gal reserve.
Only fill fuel tank until the filler nozzle unit cuts out — do not overfill.
- **Engine Oil:** Engine oil level check, see page 69.
Quantity differential between upper and lower dipstick marking level 2.0 l/2.1 US qt.
Year-round multigrade oils 10 W-40, 10 W-50.
For further information, refer to page 86.
- **Automatic Transmission:** Automatic transmission fluid for automatic transmission.
For level checks and replenishment, refer to page 71.
- **Coolant:** For normal replenishment, use water (potable water quality).
For further information (e.g. anticorrosion/anti-freeze), refer to page 90.
- **Bulbs:** High and low beams: Sealed beam/Halogen, tail and standing lamps 10 W/6 cp, turn signal, clearance and side marker lamps, front 21/5 W/32/3 cp, turn signal lamps, rear 21 W/32 cp, stop lamps 21 W/32 cp, license plate lamps 5 W festoon lamp.

- **Tire Pressure:**
For driving up to 160 km/h/100 mph

Cold tires:

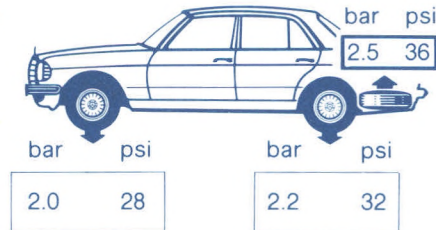

Warm tires:

Pressure may rise by up to +0.5 bar/ + 8 psi.

Never release any air from a warm tire to off-set this pressure increase!

For driving above 160 km/h/
100 mph +0.3 bar/ + 4 psi.

Daimler-Benz AG
Stuttgart-Untertuerkheim
Zentralkundendienst



Mercedes-Benz
service

