

Owner's Manual

Mercedes-Benz



190 D 2.2

1985

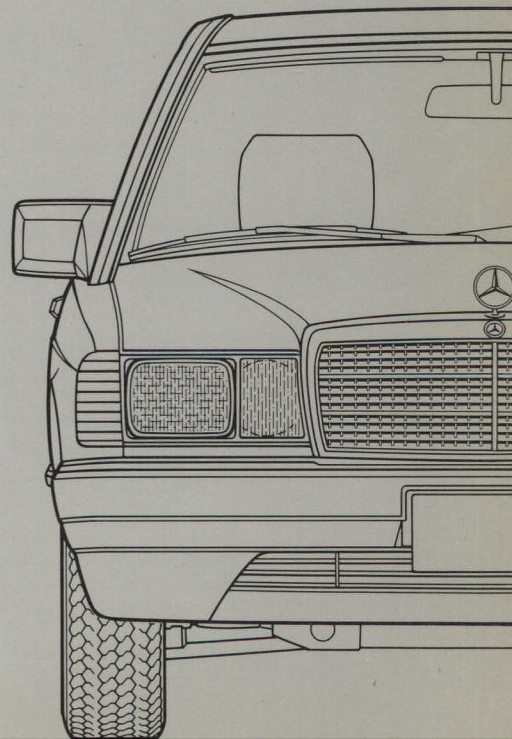

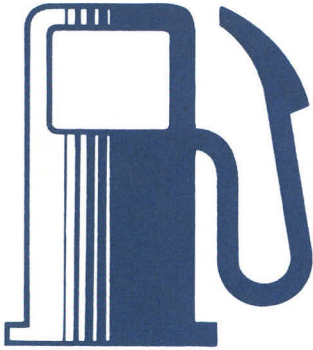

Drive Sensibly – Save Fuel

Fuel consumption depends to a great extent on driving habits and operating conditions.

In order to save fuel you should:

- ensure that tire pressures are correct
- not carry unnecessary loads
- remove ski racks or roof-mounted luggage racks when not in use
- not warm up your engine at idle and with the vehicle at standstill
- avoid frequent acceleration and deceleration
- shift gears on time, do not exceed $\frac{2}{3}$ of the individual gears' max. speed
- have all the maintenance jobs specified by us carried out at regular intervals by an authorized MERCEDES-BENZ dealer.

Driving in low temperature weather, in stop-and-go city traffic and on short hops, and in hilly country as well, increases fuel consumption.

Mercedes-Benz



Owner's Manual

190 D 2.2

Chassis 201 D

1985

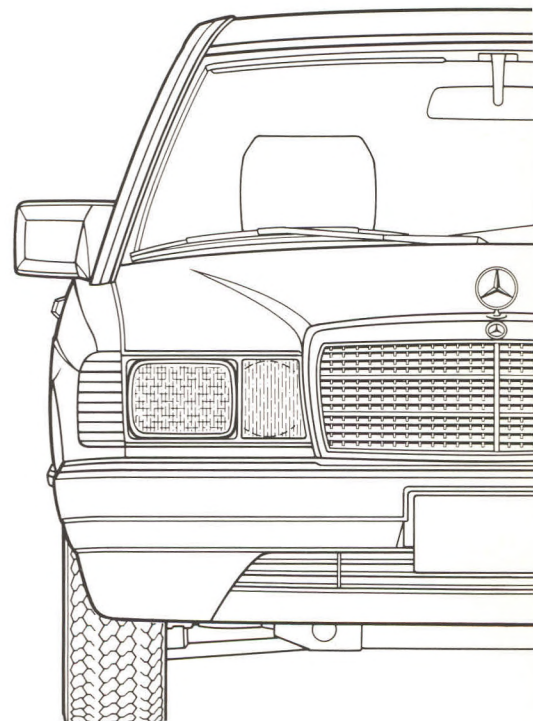

Printed in Germany

We reserve the right to modify the technical details of the vehicle as given in the data and illustrations of this Owner's Manual (s.e.e.o.). Reprinting, translation and copying, even of excerpts, is not permitted without our prior authorization in writing.

ZKD/9.84.8/MD

Our company and staff wish you many hours of enjoyment with your new vehicle.

You have placed a lot of trust in our company name by purchasing a MERCEDES, from which you may expect that it will give you long service with a minimum of trouble, and is easy to operate.

We have just one request to make, hoping that it will benefit you as well:

Please do not put this manual aside without first carefully reading it.

You may notice that it contains many important recommendations that should make the operation of your MERCEDES easier and even increase your pleasure driving it.

We wish you many miles of motoring pleasure.
Daimler-Benz Aktiengesellschaft

Special equipment is also described in this manual, including operating instructions wherever necessary. Since these are special-order items, the descriptions and illustrations herein may vary slightly from the actual equipment of your vehicle.

If there are any equipment details that are not shown or described in this Owner's Manual, your MERCEDES-BENZ dealer will be glad to inform you of correct care and operating procedures.

**Instruments and Controls, Starting the Engine
Driving Hints, Service and Maintenance**

Operation

Driving

Practical Hints

**Technical Data
Fuels, Coolants, Lubricants, etc.**

Index

Check Regularly and Before a Long Trip

See page 104

What You Should Know at the Gas Station

See last page

The First 1500 km/1000 Miles

The more cautiously you treat your engine during the break-in period, the more satisfied you will be with its performance later on. Therefore, drive your vehicle during the first 1500 km/1000 miles at moderate vehicle and engine speeds.

During this period, avoid heavy loads (full throttle driving) and high RPMs (no more than $\frac{2}{3}$ of maximum permissible speed in each gear).

Down shift at proper engine speed!

On vehicles with automatic transmission avoid accelerating by kick-down. It is not recommended to brake the vehicle by manually shifting to a lower gear. We recommend to select positions "3" or "2" only at moderate speeds (for hill driving).

After 1500 km/1000 miles, speeds may gradually be increased to the permissible maximum.

Instruments and Controls, Starting the Engine Driving Hints, Service and Maintenance

Instruments and Controls	8
Instrument Cluster	10
Starting and Turning off the Engine	12
Hints for Driving	13
MERCEDES-BENZ Maintenance System	15



Instruments and Controls

For more detailed descriptions see specified pages.

- 1 Air volume lever for side ventilation (page 18)
- 2 Adjustable side ventilation outlets (page 18)
- 3 Lighting switch (page 38)
- 4 Combination switch (page 39)
- 5 Cruise control (page 55)
- 6 Switch for rear courtesy lamp (page 42)
- 7 Instrument cluster (page 10)
- 8 Horn control
- 9 Steering lock with preglow/starter switch (page 37)
- 10 Switch for rear window defroster (page 42)
- 11 Switch for electric sliding roof (page 43)
- 12 Switch for automatic antenna (page 50)
- 13 Adjustable center ventilation outlets (page 18)
- 14 Air volume lever for side ventilation (page 18)
- 15 Glove compartment, illuminated (only in steering lock positions 1 or 2)
- 16 Air recirculation switch (page 18)
- 17 Fan speed control lever (page 18)
- 18 Tempmatic climate control system (page 18)
- 19 Radio (page 45)
- 20 Ash tray with lighter (page 43, 82)
- 21 Switch group for power windows (page 44)
- 22 Switch for hazard warning flasher system
- 23 Adjusting lever for exterior mirror on front passenger side (page 40)
- 24 Loudspeaker – fader control
- 25 Switch for left front seat heater (page 32)
- 26 Switch for right front seat heater (page 32)

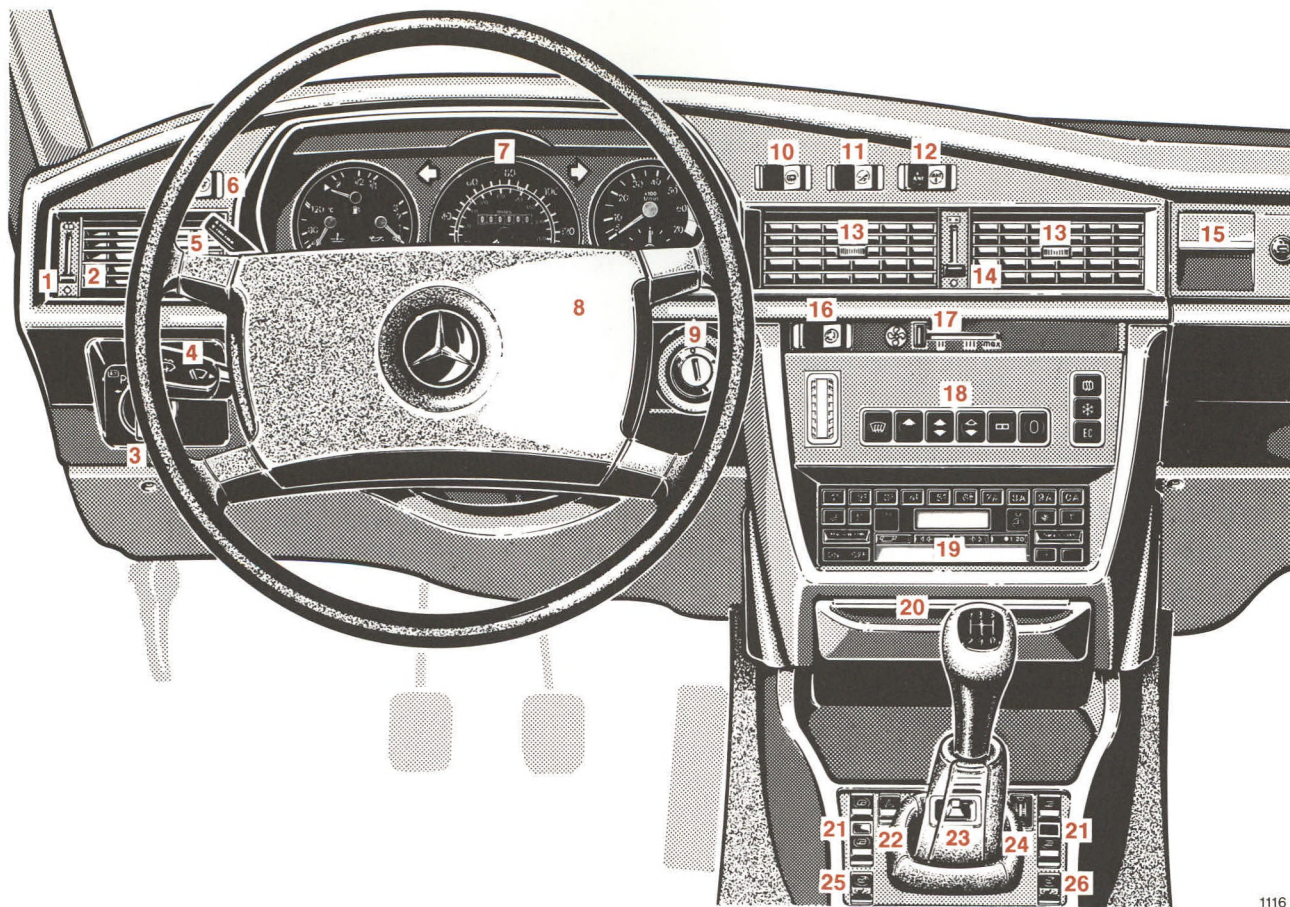



Instrument Cluster

- 1** Coolant temperature gauge
Up to red marking: Maximum permissible temperature for an anticorrosion/antifreeze-blended fill protecting down to -30°C / -22°F . See page 58
- 2** Fuel gauge with reserve warning lamp (yellow). See page 58
Fuel reserve and capacity, refer to page 92 and last page.
- 3** Oil pressure gauge (bar). See page 57
- 4** Turn signal indicator lamp, left (green)
- 5** Speedometer
- 6** Main odometer
- 7** Trip odometer
- 8** Turn signal indicator lamp, right (green)
- 9** Tachometer
- 10** Electric clock
- 11** Preglowing indicator lamp (yellow)
- 12** Seat belt warning lamp (red)
- 13** Supplemental restraint system indicator lamp (red). See page 35
- 14** ABS indicator lamp (yellow). See page 56
- 15** Low windshield washer level indicator lamp (yellow). See page 58
- 16** Knob for clock adjustment (press in for adjustments)
- 17** Outside temperature indicator. See page 58
- 18** Knob for instrument lamps and trip odometer
Rotate knob: instrument lamps intensity are infinitely variable
Depress knob: trip odometer is reset
- 19** Low engine coolant level indicator lamp (yellow). See page 58
- 20** Low engine oil level indicator lamp (yellow). See page 57
- 21** Brake warning lamp (red) comes on if
 - the parking brake is engaged
 - not enough brake fluid is in the reservoir
- 22** Brake pad wear indicator lamp (yellow): Lights up during braking if the front wheel brake pads are worn down. See page 57
- 23** Charge indicator lamp (red). See page 57
- 24** High beam indicator lamp (blue)

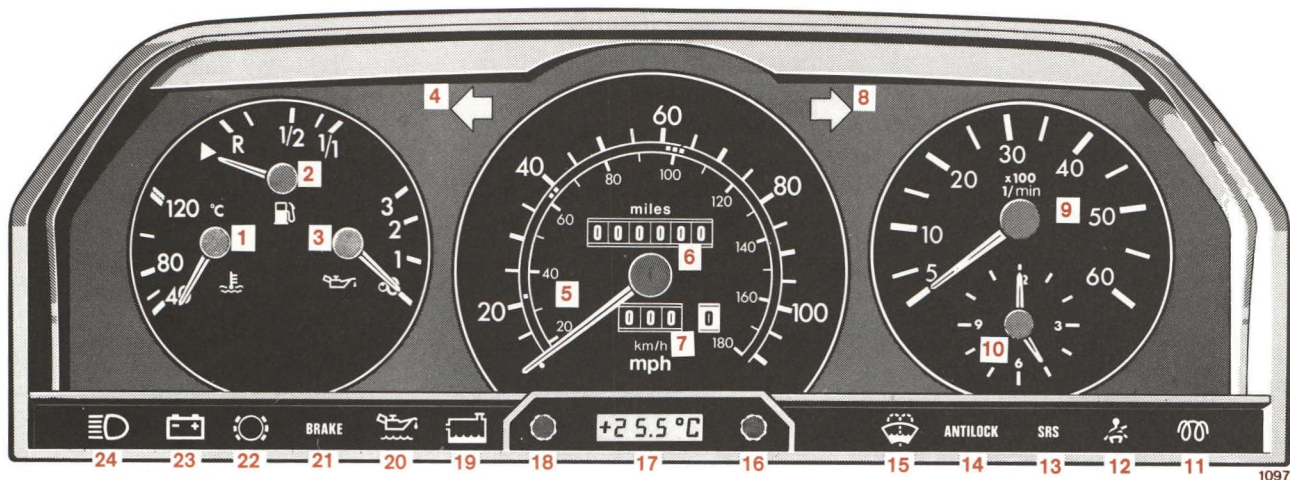

1097



Starting and Turning off the Engine

Engage parking brake before starting the engine.

Move gearshift lever to neutral (selector lever positions “P” or “N” on automatic transmissions).

Cold Engine

Turn key in steering lock to position 2. Charge indicator and preglow indicator lamp must come on. The preglow process starts. When the preglow indicator goes out, the engine is ready for starting.

Ambient Temperature exceeding 0° C/ +32° F:

Turn key in steering lock clockwise to the stop. Do not depress accelerator. Release key only when the engine is firing regularly.

Ambient Temperature below 0° C/ +32° F:

Depress accelerator and clutch pedal (if applicable) to the floor. Turn key in steering lock clockwise to the stop. Release key only when the engine is firing regularly and back off accelerator slowly.

Do not interrupt the starting process. If the engine is very cold it is possible that it will fail to start on subsequent attempts.

Hot Engine

Turn key in steering lock clockwise to the stop and start engine immediately without depressing the accelerator. Release the key as soon as the engine is firing regularly.

Turning off

Turn key in steering lock to position 0 and remove only when the vehicle has stopped.

Should the engine continue to operate with the key in steering lock position 0, refer to page 66.

With very high coolant temperatures (e.g. after driving on mountain passes), do not shut down the engine immediately but allow it to run at slightly increased idle speed for approximately 1–2 minutes.

Notes:

Due to the installed starter non-repeat unit, the key in the steering lock must be returned to 0 position before making a new starting attempt.

Observe the oil pressure gauge immediately after starting. In a very cold engine the oil pressure will only rise slowly, some time after the engine has started. Do not speed up the engine before pressure is registered on the pressure gauge.

The charge indicator lamp must go out as soon as the engine has started.

If the preglow indicator fails to light up, the preglow system is defective and should be repaired at an authorized MERCEDES-BENZ dealer at the earliest possible date.

In areas where temperatures frequently drop below –18° C/0° F, we recommend that a block heater is installed. Every MERCEDES-BENZ dealer will advise you on this subject.

Hints for Driving

Power assistance

When the engine is not running, both the service brake and the steering are without power assistance. Under these circumstances, a much greater effort is necessary to steer or stop the vehicle.

Tires

Do not allow your tires to wear down too far. With less than 3 mm/ $\frac{1}{8}$ in of tread, the antiskid properties on a wet road are sharply reduced.

Depending upon the weather and/or road pavement, the traction varies widely.

Specified tire pressures must be maintained. This applies particularly if the tires are subjected to high loads (e.g. high speeds, heavy loads, high ambient temperatures).

Aquaplaning

Depending on the depth of the water layer on the road, aquaplaning may occur, even at low speeds. Avoid track grooves in the road and apply brakes cautiously in the rain.

Tire friction

A given speed at which a vehicle driven on dry roads can still be fully controlled must be reduced when the same vehicle is to be driven safely on a wet or icy road.

You should pay particular attention to the condition of the road as soon as the prevailing temperatures fall close to the freezing point.

If ice has formed on the road, tire traction will be substantially reduced. Under such weather conditions, drive, steer and brake particularly carefully.

We recommend M+S radial-ply tires for the cold season. On packed snow, they can reduce your stopping distance as compared with summer tires. Stopping distance, however, is nevertheless considerably greater than when the road is wet or dry.

Brakes

When driving down long and steep declines, relieve the brakes by shifting into a lower speed (selector lever position "3" or "2" in the case of automatic transmissions). This prevents overheating of the brakes and reduces brake pad wear.

After hard braking it is advisable to drive on for some time so the air stream will cool down the brakes faster.

When driving in heavy rain for some time without applying the brakes, the first braking action may be somewhat reduced and increased pedal pressure may be necessary. For this reason, stay further away from vehicle in front.

The condition of the parking brake system is checked each time the car is in the shop for maintenance.

Between maintenance checks it is a good practice to apply the parking brake once or twice while driving at approximately 50 km/h/30 mph on a dry road. Apply brake lightly until a slight drag on the wheels is felt. Keep applying brakes for about 10 seconds while holding release button in before releasing parking



brake completely. This practice will keep the parking brake at maximum efficiency.

Warning:

The stop lamps will not come on when applying the parking brake only. Apply parking brake only when road behind vehicle is clear of traffic.

All checks and maintenance work on the brake system should be carried out by a MERCEDES-BENZ dealer.

If the parking brake is released and the brake warning lamp in the instrument cluster stays on, the brake fluid level in the reservoir is too low.

Brake pad wear or a leak in the system may be the reason for low brake fluid in the reservoir.

Have the brake system inspected at an authorized MERCEDES-BENZ dealer.

Install only brake pads recommended by us.

If other than recommended brake pads are installed, the braking properties of the vehicle can be affected to an extent that the safety is substantially impaired.

Driving Hints During the Winter Season

The most important rule for slippery or icy roads is to drive sensibly and to avoid abrupt acceleration, braking and steering action. Do not use the cruise control system under such conditions.

When the vehicle is in danger of skidding, declutch or – in case of an automatic transmission – move selector lever to position “N”. Try to keep the vehicle under control by means of corrective steering action.

Provided the traffic conditions will allow, only brake in a way that the wheels are locked for no more than fractions of a second as otherwise the steerability of the vehicle is lost.

Road salts and chemicals can adversely affect braking efficiency.

Increased pedal force may become necessary to produce the normal brake effect. We therefore recommend depressing the brake pedal repeatedly when traveling on salt-strewn roads at length. This can bring road salt impaired braking efficiency back to normal. A prerequisite is, however, that this is possible without endangering other drivers on the road.

If the vehicle is parked after being driven on salt treated roads, the braking efficiency should be tested as soon as possible after driving is resumed while adhering to the safety requirements.

MERCEDES-BENZ Maintenance System

A maintenance booklet is delivered with your car listing all the maintenance jobs that must be carried out after the following mileages:

Routine Maintenance

Inspection at
1300–1600 km/800–1000 miles
Lubrication Service every
8000 km/5000 miles
Maintenance Service every
24 000 km/15 000 miles
Additional Work every
48 000 km/30 000 miles

In the case of low mileage operation, the Maintenance Service must be carried out at least once every 2 years.

Engine Oil and Filter Change

Required every 8000 km/5000 miles, or at least once a year when using year-round multigrade oil; otherwise at least twice a year (spring and fall).

Under severe operating conditions or if diesel fuels with high sulphur content (in excess of 0.5% by weight) are used, the oil and filter should be changed every 4000 km/2500 miles.

For engine oil recommendations, see page 90.

Severe Operating Conditions

In the case of severe operating conditions or heavy use mainly in city traffic or over short distances, frequent mountain driving, poor roads, dusty and muddy conditions, trailer operation, hard and sporty driving etc., it may be necessary to carry out maintenance work at shorter than normal intervals, as follows:

Engine: Oil change with filter change every 4000 km/2500 miles
Automatic transmission: Fluid change without filter change every 24 000 km/15 000 miles

Tires: Inspect

Air cleaner: Clean or replace element

Special Maintenance Measures

Brake fluid should be replaced annually, preferably in the spring.

It is recommended to use only brake fluid approved by MERCEDES-BENZ.

The coolant should be checked for sufficient protection before the start of and during the cold season.

Have the coolant (water/anticorrosion/antifreeze mixture) replaced at least every three years (see “Fuels, Coolants, Lubricants, etc.”).

Maintenance Vouchers

Your authorized MERCEDES-BENZ dealer will certify in the maintenance booklet that all lubrication and maintenance services have been carried out at the correct intervals.

Stickers to remind you when the next lubrication service or maintenance service is due, or when the brake fluid must be changed, are provided in the middle of the maintenance booklet.

Sticker attaching points

In the frame of the driver's door: Lubrication service and maintenance service

In the engine compartment: Brake fluid change.

Operation

Tempmatic Climate Control System	18
Keys	24
Opening the Doors	25
Locking and Unlocking of Doors	25
Central Locking System	26
Anti-Theft Alarm System	27
Manual Seat Adjustment, Front	28
Adjusting Power Seats, Front	29
Orthopedic Seat Backrest	30
Safety Head Restraints, Rear	30
Arm Rest (Rear Seat)	31
Arm Rest (Front Seats)	31
Heated Seats	32
Supplemental Restraint System – Seat Belts, Emergency Tension- ing Retractors, Driver Airbag	33
Steering Lock	37
Lighting Switch	38
Combination Switch	39
Exterior Mirrors	40
Inside Rear View Mirror	40
Sun Visors	41
Interior Lamps	41
Rear Window Defroster	42
Lighter	43
Sliding Roof	43
Power Windows	44
Shelf below Rear Window	44
Electronic Radio	45

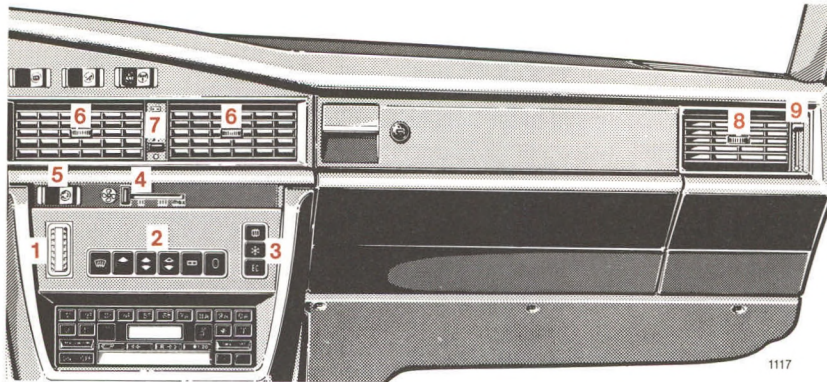

The button symbols light up when the vehicle's head lamps are turned on (not with parking lamps). The symbol is brighter when depressed.







The engine must be running for the air conditioning system to work.

Close all windows and the sliding roof to ensure proper operation of the system. Air outlet temperature is controlled automatically.



Note:

The air conditioner removes considerable moisture from the air during operation. It is normal if water drips on the ground from under the car.

- 1 Temperature selector wheel
- 2 Air distribution control push buttons (press only one button at a time)

-  = Defrost or fast defogging
-  = Defogging inside glass
-  = Heating and cooling
-  = Normal heating
-  = Normal cooling or fresh air ventilation
-  = No fresh air supplied

- 3 Air conditioning mode control (press only one button at a time)

-  = Max. cooling
-  = Normal setting
-  = Economy setting (No A/C)
- 4 Fan speed control lever
- 5 Air recirculation switch
- 6 Instrument panel center outlets
- 7 Air volume lever for center outlets (6)
- 8 Instrument panel side outlets
- 9 Air volume lever for side outlets (8)

Air Distribution

Air conditioned, warmed, or fresh air may be directed to the foot area, the windshield, and the side outlets (8). The center outlets (6) are for non-heated air only.

The air volume through the center outlets (6) and side outlets (8) may be changed with levers (7) and (9) respectively. Pushing the lever up opens the air outlets completely.

Temperature Selection



Use the temperature selector wheel to set the desired temperature. The selected temperature is reached as quickly as possible and maintained. Use a basic setting of “22”. Refine your setting only in small steps to avoid large temperature fluctuations.

“MIN” (notched-in) = maximum cooling or fresh air dependent on push button selection of the air conditioning mode control.

“MAX” (notched-in) = maximum heating.

A/C Mode Control Switch



Position **EC** (Economy) = Economical setting.

In this setting the air conditioning compressor stays off. Temperature regulation is maintained only during the heating phase.



Position  = Normal cooling, the air conditioning compressor is switched on.





The vehicle may be heated or cooled as desired. The compressor comes on as soon as the vehicle's interior temperature exceeds the selected temperature. The selected temperature is then maintained by regulating the compressor on-time.



Position  = Max. cooling, the air conditioning compressor is switched on.

The climate control system works at maximum capacity, removing moisture from either fresh air or recirculated air and defogs inside glass. The max. cooling mode, is recommended during humid weather and when windows must be defogged from inside.

Fan Speed Selection

When pushing one of these buttons , ,  or button , the fan speed will correspond to the particular position of lever (4).

The volume of fresh air supplied to the vehicle interior can be increased by pushing lever (4) to the right.

The fan speed may be changed by moving lever (4) to position "II", "III" or "max". The fresh air intake may be temporarily closed (press push button ) if driving through dusty areas or annoying odors enter the car interior.

Function  = Continuous max. air volume.



Air Recirculation Switch

Pressing the switch (symbol-side) down, causes air to be recirculated with only a small amount of fresh air. The indicator lamp should be on (do not push  button). This setting can also be used if annoying odors are entering the car's interior. At high outside temperatures the air conditioning system is automatically in the recirculation mode, providing increased cooling.

Note:

The air recirculation switch should never be on in  defrost or when inside of glass tends to fog up.

Fast Cooling

- Turn temperature selector wheel (1) and lock in extreme end position "MIN".
- Push button  or  in climate control switch (3).
- Push  button.
- Push lever (4) to far right "max" position.
- For maximum air flow push up levers (7) and (9).
- Close windows and sliding roof completely.

Open the windows and/or sliding roof long enough to let hot air inside the car escape. This helps reduce the time the air conditioner must run before the car cools. Then, close windows and/or sliding roof and allow air conditioner to operate normally.

Examples of Air Flow Adjustments

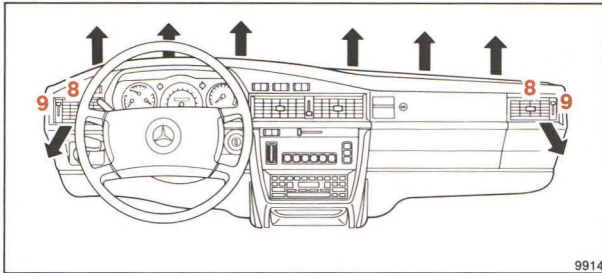



 Press to defrost or quickly defog windows.

Maximum heated air is directed to the windshield and side windows, independent of the temperature dial (1) setting, climate control switch (3) and lever (4) position. The air volume through outlets (8) may be adjusted with levers (9) as desired.

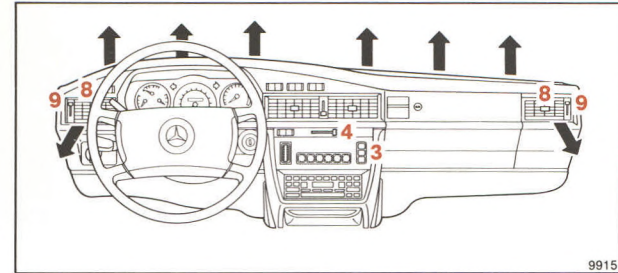
Air recirculation switch must be off.



 Press to defog the windshield from inside

Air is directed to the windshield in the heating or cooling mode. Press button  of climate control switch (3) and increase fan speed for a short period with lever (4). Adjust levers (9) for the desired air flow through outlets (8).

It is possible for condensation to form on the outside of the windshield in humid weather in this mode. If this happens, change the air flow or decrease the fan speed.

Air recirculation switch must be off.

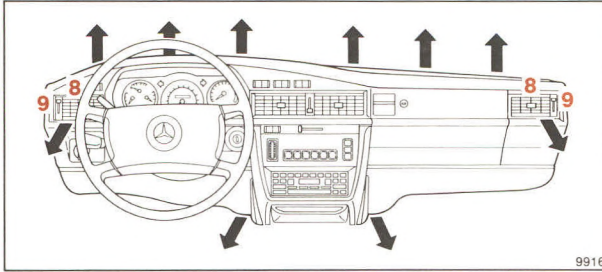

 Press for heating with air conditioned air.

In this type of operation, air is directed to the windshield and the foot area. The air outlets (8) may be opened or closed with levers (9) as desired.

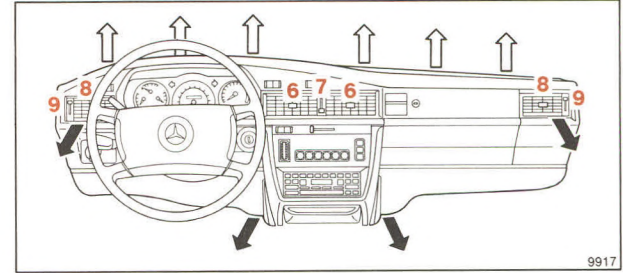

 Press for normal heater operation.

Most of the air is directed to the foot area during heater operation. A small amount of air is directed to the windshield, just enough to keep it from fogging up during normal weather conditions. The air outlets (6) and (8) may be opened or closed with levers (7) and (9) respectively as desired. Only non-heated air is directed through outlets (6).

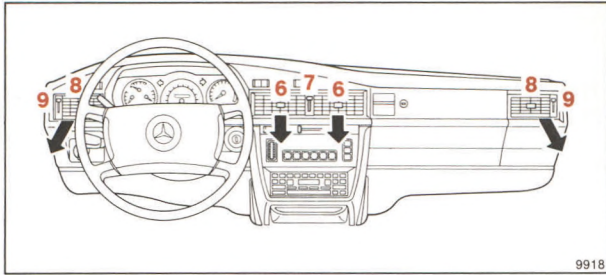

 Press for fresh air ventilation or air conditioning.

For taking in fresh air or during air conditioner operation, the air is directed to outlets (6) and (8). Adjust the air flow with levers (7) and (9) respectively as desired.

 Press to shut off air entry.

Fresh air into the vehicle is shut off. Use this button, for example, to prevent outside odors or water from car washes from entering the vehicle's interior. Do not drive the vehicle with this setting for long periods with windows and sliding roof closed since the vehicle's normal interior airflow will be disrupted.

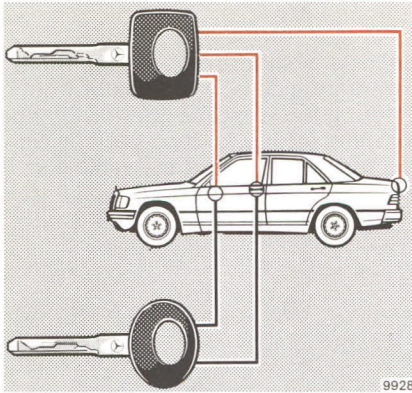

Master Key – square head – fits all locks on the car.

Supplementary Key – rounded head – fits only the door locks and the steering lock. This key is intended to be used whenever the car is left with an attendant. Be sure to lock glove compartment and trunk with the master key.



Flat Key

The flat key fits all vehicle locks. We recommend that you carry the flat key with you and keep it in a safe place so that it is always handy, if needed (e.g. in your wallet). Never leave the flat key in the vehicle.

Obtaining Replacement Keys

You are given 4 keys with your vehicle. Replacement keys can be obtained only via an authorized MERCEDES-BENZ dealer. For security reasons, obtaining replacement keys requires considerable time.

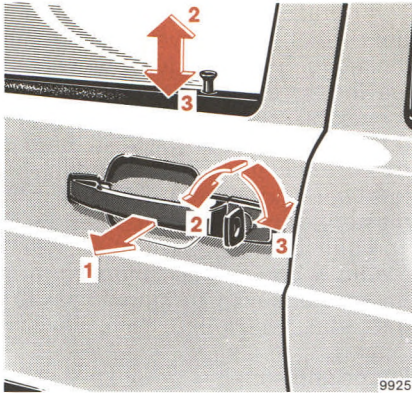

Opening the Doors

From outside: pull handle outwards (1).

From inside: pull handle in door trim panel (4).

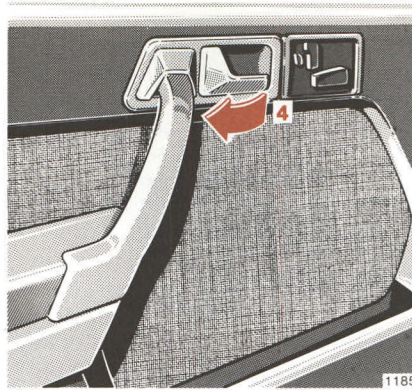

Locking and Unlocking of Doors

From the outside: turn key.

From the inside: actuate button.

- 2 Unlocking
- 3 Locking

When the rear door buttons are pushed down, the rear doors cannot be opened from the outside or the inside. They can only be opened after pulling buttons up.

One cannot lock:

- the driver's door if it is open
- any door if the door lock has not engaged fully. In this case open the door and close it again.



Central Locking System

The entire vehicle may be locked or unlocked with the central locking system:

- Using the master key, supplementary key, or by pushing down or pulling up the interior door lock buttons at the front doors.
- From the trunk using the master key only.

The central locking system allows you to lock or unlock all doors, trunk lid and fuel filler flap simultaneously.

Doors

When you lock the car, all door lock buttons should move down. If any one stays up, the respective door was not properly closed. You should then unlock the car, open and re-close this door, and lock the car again.

Note:

The central locking system can be engaged from the driver-side door lock button, provided the door is completely closed. It can also be engaged from the passenger-side if the key is removed, or engaged in the steering lock without being turned (key in position 0).

Trunk

To unlock the trunk with the central locking system, turn the master key in the trunk lock completely to the left and let it return to the normal position. Push in trunk lock button and open the trunk. To lock the trunk, turn the master key completely to the right and let it return to the normal position.

The trunk can remain locked while the central locking system is unlocked (e. g. while driving or when leaving the car in a situation where it must be driven using the supplementary key but you wish the trunk to remain locked at parking lots, workshops, etc.). Turn the master key completely to the right and pull it out in that position. Now the trunk can only be unlocked with the master key by turning it back to the left.

Important!

Contrary to prior model year vehicles, if the trunk is unlocked with the central locking system engaged, the doors and fuel filler flap will also be unlocked. After closing the trunk, the central locking system must again be engaged using the key!

Note:

If the fuel filler flap cannot be opened, refer to “Unlocking of Fuel Filler Flap” (page 75).

Anti-Theft Alarm System

The anti-theft alarm can be armed or disarmed with the master key (identified by red dot) by locking or unlocking either front door or the trunk.

Operation

Once the alarm system has been armed, the vehicle lamps will flash and the horn will sound intermittently when an unauthorized person tries to:

- open a door
- open the trunk
- remove the radio
- switch on or bridge the steering lock
- step on the brake pedal
- raise the vehicle, i.e. towing away.

The alarm will last approximately 150 seconds in the form of blinking exterior lamps. At the same time an additional horn will sound intermittently for 60 seconds, and repeat for another 60 seconds after a 30 second pause.

The alarm will stay on even if the arming element (a door, for example) is immediately closed.

To avoid setting off the alarm unintentionally, do not arm the alarm system in the following situations; e.g.: Auto ferry, auto train, when hitching/unhitching a trailer, or heavy loading/unloading. For this purpose use the supplementary key and not the master key for locking the vehicle.

Special function

To activate the anti-theft alarm from the trunk, turn the master key in the trunk lock completely to the right and pull it out in this position.

If you want the alarm system to be armed at the trunk only, turn the master key in the trunk lock completely to the right and pull it out in that position. Then disarm the rest of the vehicle by unlocking either front door with the master key. You can now lock or unlock the doors and filler flap, as well as start the engine, in the usual manner using the supplementary key.

Do not give the master key to an unauthorized person. We recommend that you carry the flat key safely with you (e.g. in your wallet) so that it is always handy, if needed. This key has the same function as the master key.

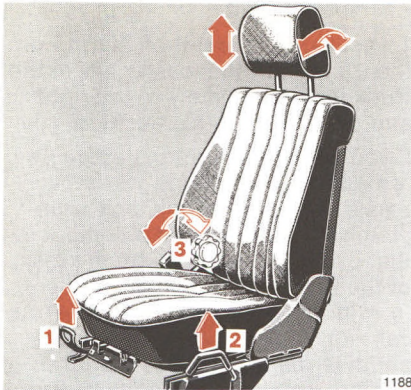

Manual Seat Adjustment, Front

Fore/aft adjustment: lift handle (1); slide seat to desired position and allow handle to re-engage.

Height of seat: raise lever (2); to raise seat, slide seat forward; to lower seat, slide seat backward; allow lever to re-engage.

Seat back position: turn handwheel (3). For full reclining of backrest, seat should be moved to one of the forward-most positions and head restraint removed. For driving, return backrest to upright position and push seat back. Replace head restraint.

Safety head restraint: to adjust the height of the head restraint, pull it slightly forward while lifting or pushing down. Adjust head restraint to support the back of the head approximately at ear level. However, do not pull up the head restraint past the detent.

To remove head restraint refer to "Practical Hints".

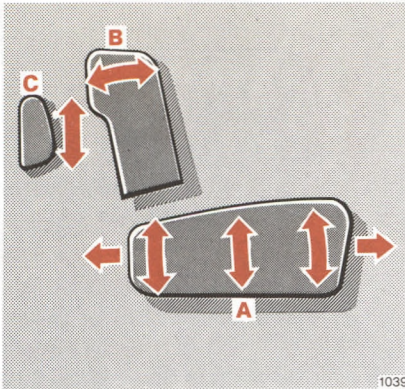

Adjusting Power Seats, Front

The switches are located in each front door.

Turn key to steering lock position 2 (with the driver's door opened, the power seats can also be operated with the key removed or in steering lock position 1 or 0).

Seat and head restraint adjustment:

- A Seat cushion adjustment.
- B Seatback adjustment.
- C Head restraint adjustment.

Adjust head restraint to support the back of the head approximately at ear level. The head restraint can also be turned forward by hand.

Note:

The head restraint should not be pulled up past the detent when making adjustments.

Caution!

Do not make adjustments with vehicle in motion.

To remove head restraint refer to "Practical Hints".

Note:

Prior to operating the vehicle, the driver should adjust the seat height for proper vision as well as fore/aft placement and seat back angle to insure adequate control, reach, operation, and comfort. Be certain seat is "locked in" by sliding front/rear until full engagement is assured.

The head restraint should also be adjusted for proper height so that when the cushion is tipped completely forward, it should form a cradle behind the seat occupant's head. Both the inside and outside rear view mirrors should then be adjusted for adequate rearward vision. Fasten seat belts. Children under the age of six or under the weight of 23 kg/50 lb should be seated in the back seat with an approved restraint system properly secured.

All seat, head restraint, and rear view mirror adjustments as well as fastening of seat belts should be accomplished before the vehicle is put into motion.

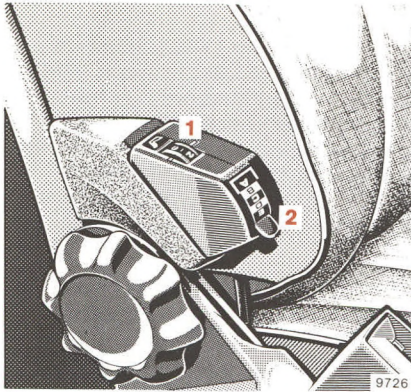

Orthopedic Seat Backrest

The seats have an inflatable air cushion built into the backrest to provide additional lumbar support. The amount of cushion height and curvature may be adjusted after turning the key to steering lock position 2.

The inflation pressure of the air cushion may be continuously varied between position "0" = without pressure, and position "4" = maximum pressure, by changing the pressure regulator (1) setting.

In addition, the cushion height may be changed to five different settings between position "A" = lowest setting, and "E" = highest setting, by varying the height regulator (2) adjustment.

If a driving trip is temporarily interrupted, the last cushion setting is retained in memory, and automatically adjusts the cushion to this setting when the trip is continued.

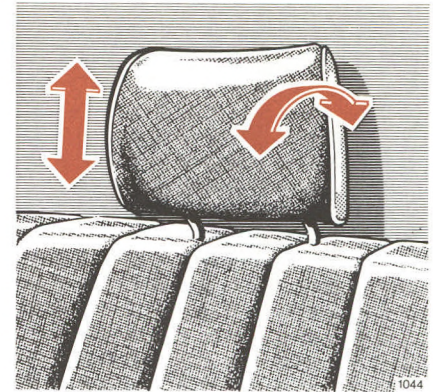

Safety Head Restraints, Rear

Adjust head restraint to support the back of the head approximately at ear level. Do not extend the head restraint past the stop.

For removal of head restraint refer to "Practical Hints".

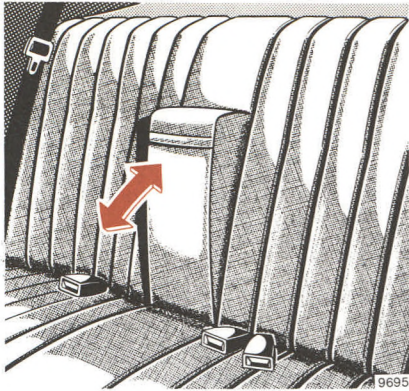

Arm Rest (Rear Seat)

The rear seat is equipped with an arm rest, which may be pulled out by the loop.

For removal of rear seat cushion, see "Practical Hints".

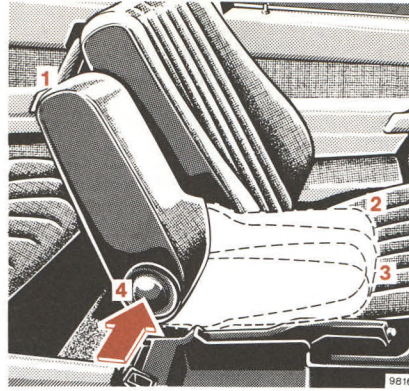

Arm Rest (Front Seats)

The arm rest engages in 3 positions.

Position 1 = arm rest folded up.

Position 2 = for normally inclined seat back.

Position 3 = for extremely inclined seat back.

For downward adjustment of the arm rest, depress release button (4).

Warning!

The arm rest does not suffice as a child restraint system. In case of a frontal collision a child can be catapulted forward over the locked arm rest.

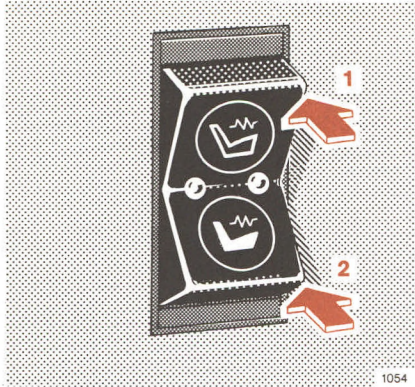

Heated Seats

The heaters can be turned on after first turning the key to steering lock position 2.

Heater operation:

Push in upper switch portion; position 1 = normal heater operation, one indicator lamp lights up.

Push in lower switch portion; position 2 = rapid heating, both indicator lamps light up.

After approximately 5 minutes in the rapid heating mode, the heater automatically switches to normal operation and only one indicator lamp will stay on.

Turning off heater:

If one indicator lamp is on, press in upper part of switch, position 1.

If both indicator lamps are on, press in lower part of switch, position 2.

The heater automatically turns off after approximately 30 minutes of operation.

Note:

When in operation, the seat heater consumes a large amount of power. It is advisable not to use the seat heater longer than necessary.

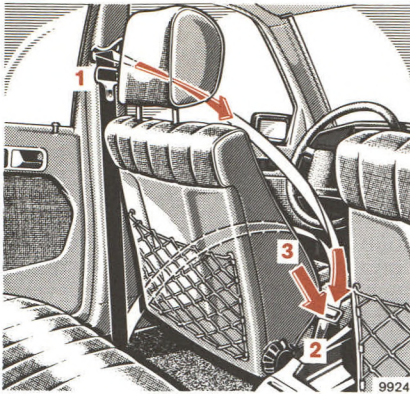

Supplemental Restraint System – Seat Belts, Emergency Tensioning Retractors, Driver Airbag

Seat Belts and Emergency Tensioning Retractor

Your vehicle is equipped with seat belts for all seats and emergency tensioning retractors for front seats. The tensioning retractors are located in each belt's inertia reel and become operationally ready with the key in steering lock position 1 or 2.

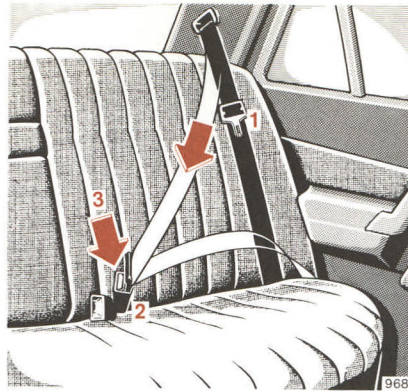

Warning system:

The indicator is illuminated for 4–8 seconds after turning the steering lock key to position 2. If the seat belt of the driver's seat is not fastened a warning buzzer sounds simultaneously.

Fastening:

- Pull belt with latch plate (1) over shoulder and lap. Do not twist the belt doing this.
- Push latch plate (1) into buckle (2) until it clicks.

- The belt must be pulled snug and checked for snugness immediately after engaging it and during driving. If necessary, tighten the lap portion to a snug fit by pulling shoulder portion up.

Unfastening:

- Push in the red button (3) in the belt buckle.
- The retractor should completely rewind the belt and latch plate (1).

Operation:

The inertia reel stops the belt from unwinding during sudden vehicle stops or when quickly pulling on the belt.

The locking function of the reel may be checked by quickly pulling out the belt.

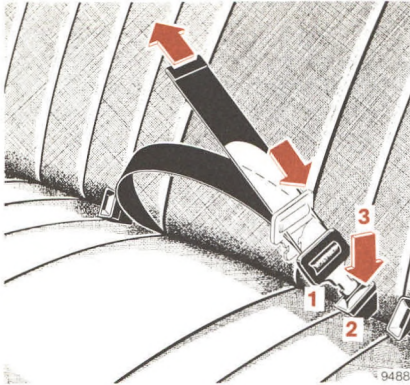

Lap belt in rear passenger compartment:

Pull belt with latch plate (1) across the lap and push latch plate into buckle (2) until it clicks. The belt must not be twisted and must be tight.

To shorten the belt, pull belt end with the tongue engaged. To lengthen the belt, turn the latch plate so that it is at a little more than 90° to the belt and pull before fastening the belt.

To disengage the belt, push red button (3) in the buckle.

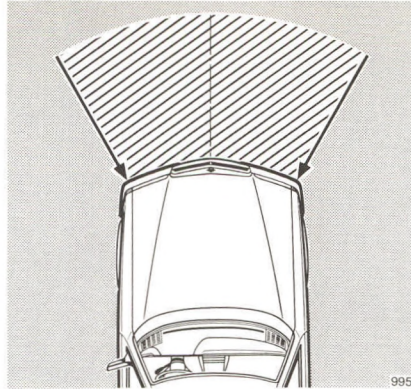

The emergency tensioning retractors are designed to activate only during severe frontal impacts. They tighten the belts in such a way that they fit more snugly against the body restricting as much as possible its forward movement.

In cases of less severe frontal impacts, such as roll-overs, side or rear collisions, or other accidents without severe frontal forces, the emergency tensioning retractors will not be activated. The driver and passengers will then be protected by the fastened seat belts and inertia reel in the usual manner.

Notes:

Rear seat passengers should always wear seat belts – for their own protection and to avoid endangering the driver and front passenger with their unrestricted forward movement.

No seat belt can be used for more than one person. Children under the age of six or under the weight of 23 kg/50 lb should be seated in the back seat with an approved restraint system properly secured.

Child restraint systems recommended by us can be fastened to the existing seat belts. Any authorized MERCEDES-BENZ dealer will gladly advise you on this subject.

For cleaning and care of the seat belts, see page 79.

For seat belt and emergency tensioning retractor safety rules, see page 36.

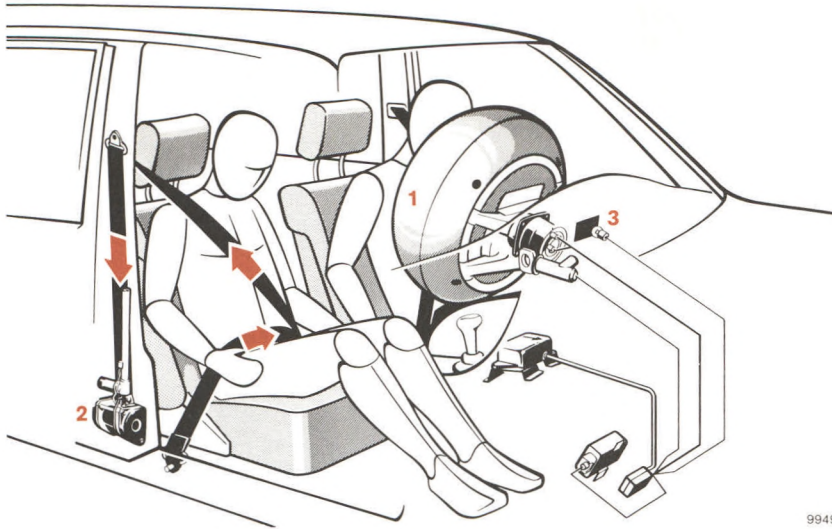

9949

Driver Airbag

If your vehicle is additionally equipped with a driver airbag, this can be recognized by the letters "SRS" stamped into the steering wheel hub pad and by the indicator lamp "SRS" (Supplemental Restraint System) in the instrument cluster.

The airbag (1) is located in the steering wheel hub and, in conjunction with wearing the seat belts with tensioning retractors (2), provides increased protection for the driver.

The operational readiness of the supplemental restraint system (airbag and emergency tensioning retractor) is verified by the indicator lamp "SRS" (3) in the instrument cluster. With the steering lock key in position 1 or 2, the indicator lamp comes on for about 10 seconds then goes out. If it doesn't come on, doesn't go out, flickers on and off, or comes on while driving, the system is malfunctioning.

This will not cause the supplemental restraint system to be activated. However, we strongly recommend that you visit an authorized MERCEDES-BENZ dealer immediately to have the system checked; otherwise the "SRS" may not be activated in a severe frontal accident.

The airbag is designed to activate only in severe frontal impacts (see illustration on page 34). Only during these types of impacts will it provide its supplemental protection. The driver should always wear the seat belt, otherwise it is not possible for the airbag to provide its intended protection.



In cases of less severe frontal impacts, such as roll-overs, side or rear collisions, or other accidents without severe frontal forces, the airbag will not be activated. The driver and other passengers will then be protected by the fastened seat belts.

The activation of the “SRS” temporarily releases a small amount of dust from the driver airbag and all of the seat belt emergency tensioning retractors. This dust, however, is neither injurious to your health, nor does it indicate a fire in the vehicle.

The service life of the airbag extends to the date indicated on the glove compartment sticker. To provide continued reliability after that date, it should be inspected by an authorized MERCEDES-BENZ dealer at that time.

Safety Guidelines for the Supplemental Restraint System – Seat Belts, Emergency Tensioning Retractor and Airbag

Damaged belts or belts that were highly stressed in an accident must be replaced and their anchoring points must also be checked. Use only belts installed or supplied by MERCEDES-BENZ.

Do not pass belts over sharp edges.

Do not make any modification that could change the effectiveness of the belts.

An airbag or tensioning retractor that was activated must be replaced.

No modifications of any kind may be made to any components or wiring of the “SRS”. This includes the installation of additional trim material, badges, etc. over the steering wheel hub and installation of additional electrical/electronic equipment on or near “SRS” components and wiring.

Improper work on the system, including incorrect installation and removal, can lead to possible injury through an uncontrolled activation of the “SRS”. In addition, through improper work there is the risk of rendering the “SRS” inoperative. Work on the “SRS” must therefore only be performed by an authorized MERCEDES-BENZ dealer.

When scrapping the airbag unit or tensioning retractor, it is mandatory to follow our safety instructions. These instructions are available at every authorized MERCEDES-BENZ dealer.

When you sell the vehicle we strongly urge you to give notice to the subsequent owner if it is equipped with an “SRS” by alerting him to the applicable section in the Owner’s Manual.

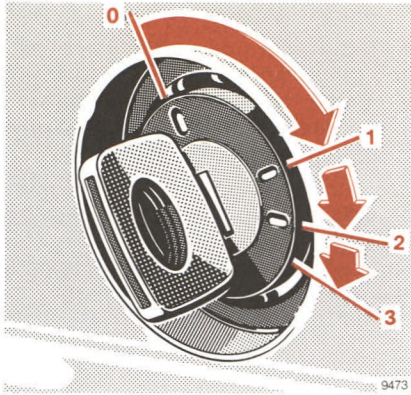

Steering Lock

- 0 Steering is locked when the key is withdrawn and the steering lock is engaged. The key can be withdrawn only in zero position.

Note:

Do not remove key from steering lock while the vehicle is in motion as this will cause the engagement of the steering lock thus rendering the vehicle inoperable.

- 1 Steering is unlocked.
(If necessary, move steering wheel slightly to turn the key clockwise to position 1.)
- 2 Preglowing and driving position.
- 3 Starting position.

For starting and turning off the engine, refer to page 12.

Notes:

The following items can be operated with the key in steering lock position 1:

Wiper, windshield washer, head-lamp flasher, electric lighter, glove compartment lamp, radio, electric sliding roof drive, rear window defroster, power windows.

A warning buzzer sounds when the key has been left in steering lock positions 1 or 0 and the driver's door is opened.

With the engine at idle speed, the charging rate of the alternator (output) is limited.

It is therefore recommended to turn off unnecessary electrical consumers while driving in stop and go traffic. This precaution helps to avoid draining of the battery.

Unnecessary strain on the battery and charging system may be minimized by turning off the following power consumers, for example: Heater in heated seats, rear window defroster.

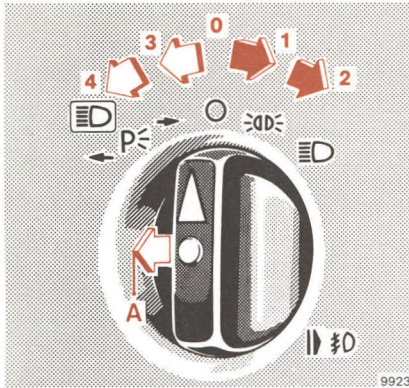

Lighting Switch

- 0 Off-position
- 1 Parking lamps (includes side marker lamps, tail lamps, license plate lamps, instrument panel lamps)
- 2 Same as pos. 1 plus headlamps
- 3 Standing lamps, right
- 4 Standing lamps, left
- A Turn to position 1 or 2 and pull out to first detent = same as position 1 or 2 plus fog lamps

Notes:

With the steering lock key removed and the driver's door open a warning buzzer sounds if the vehicle's exterior lamps are not switched off (standing lamps excepted).

Fog lamps will operate with the low or high beam headlamps, or with the parking lamps.

Fog lamps are turned off automatically when lighting switch is returned to off-position.

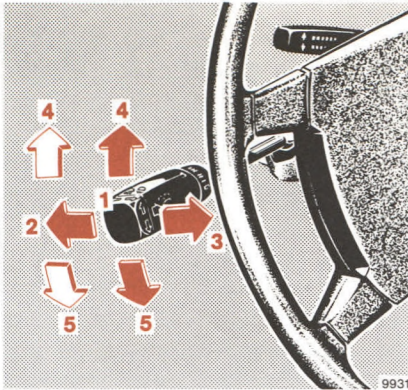

Combination Switch

- 1 Low beam (with lighting switch turned clockwise two notches)
- 2 High beam (with lighting switch turned clockwise two notches)
- 3 High beam flasher (high beam available independent of lighting switch position)
- 4 Turn signals, right
- 5 Turn signals, left

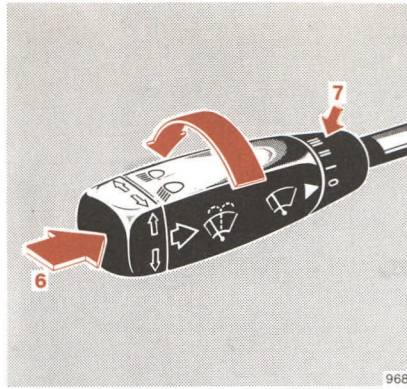

- 6 Control for windshield washer system

When the washer system is switched on, the wipers also operate.

- 7 Windshield wiper control
 - 0 Windshield wiper switched off
 - I Intermittent wiping
 - II Normal wiper speed
 - III High wiper speed

Hint:

If one of the turn signals fails, the turn signal indicator system flashes and sounds at a faster sequence than under normal operating conditions.

To operate the turn signals, move the combination switch past the point of resistance (up or down). The switch is automatically canceled when the steering wheel is turned by a large enough angle.

To signal minor directional changes of the vehicle, such as changing lanes on a highway, move combination switch to the point of resistance only and hold it there.

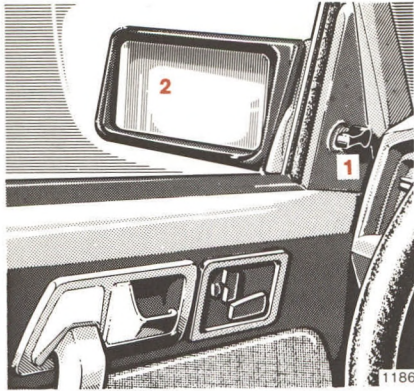

Exterior Mirrors

Driver's side:

The exterior mirror (2) can be adjusted from inside the vehicle by moving adjusting lever (1) in the desired direction.

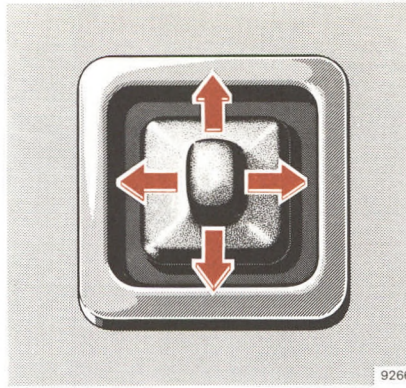

Passenger side:

Turn key in steering lock to position 2. The exterior mirror can be adjusted by means of the switch.

Note:

If the mirror housing has been forcibly moved from its normal position, it must be repositioned by applying firm pressure.

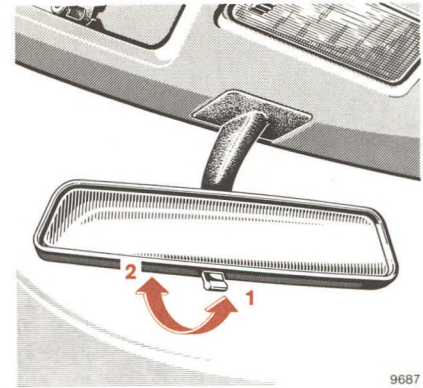

Inside Rear View Mirror

The mirror can be tilted to the anti-glare night position by means of the lever at its lower edge.

1 = Normal position

2 = Anti-glare night position.

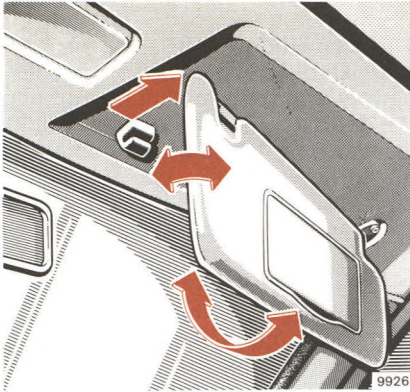

Sun Visors

Swing sun visors down to protect against sun glare.

If sunlight enters through the side window, disengage visor from inner mounting and swing to the side.

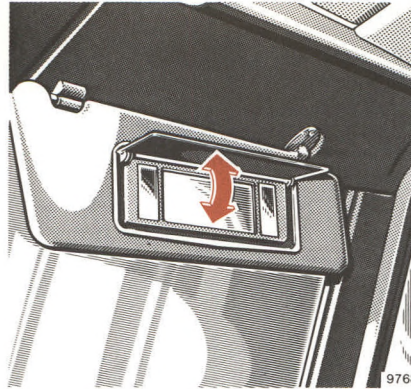

Vanity mirror:

Swing down sun visor. The lamps are switched on when the cover is opened. For this purpose the visor must be engaged in its inner mounting.

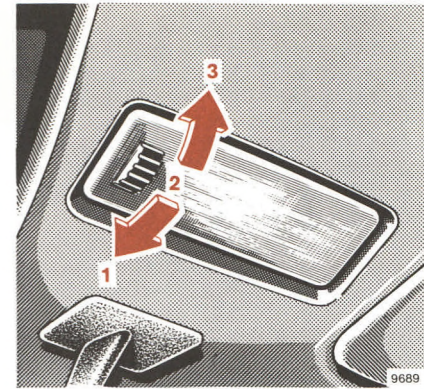

Interior Lamps

The switch for the front lamp has 3 positions.

Position 1: the lamp is switched on and off (delayed) by the front door contact switches.

Position 2: lamp switched off permanently.

Position 3: lamp switched on permanently.

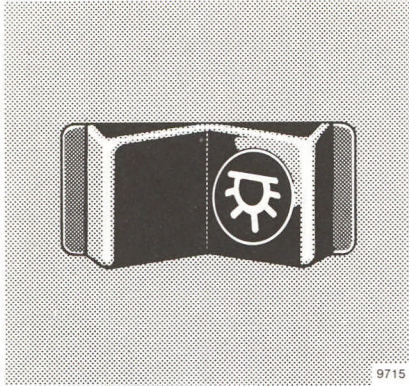

The rear courtesy lamp is switched on and off by the rear door contact switches or by the rocker switch on the instrument panel.

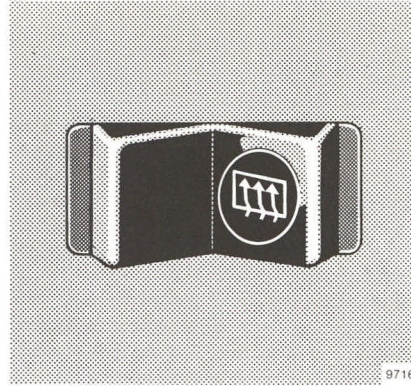

Rear Window Defroster

With engine running, press symbol side of rocker switch to turn on, press left side to turn off.

When activating the rear window defroster, the indicator lamp inside the switch will come on.

Note:

The rear window defroster uses a large amount of power. To keep the battery drain to a minimum, turn off the defroster as soon as the window is clear. The defroster is automatically turned off after a maximum of 20 minutes of operation. Heavy accumulation of snow and ice should be brushed and cleaned off before activating the defroster.

If several power consumers are turned on simultaneously, or the battery is only partially charged, it is possible that the defroster automatically turns itself off. When this happens, the indicator lamp inside the switch starts blinking. As soon as the battery has sufficient voltage, the defroster automatically turns itself back on.

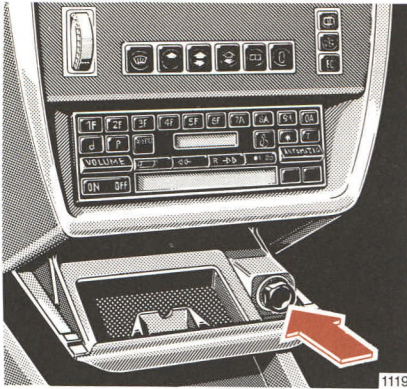

Lighter

Turn key in steering lock to position 1 or 2.

Press in lighter; it will pop out automatically when hot.

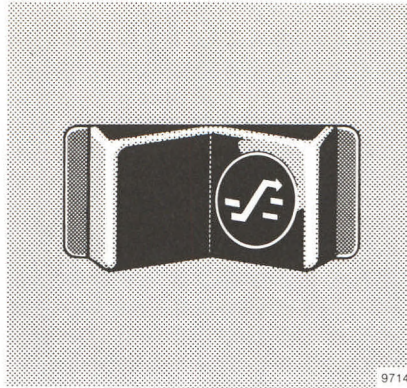

Sliding Roof

Turn key in steering lock to position 1 or 2.

Press symbol-side of rocker switch to open roof. Press left side to close roof.

If the electric drive fails, the sliding roof can also be moved by hand. Refer to "Emergency Operation of Sliding Roof" (page 75).

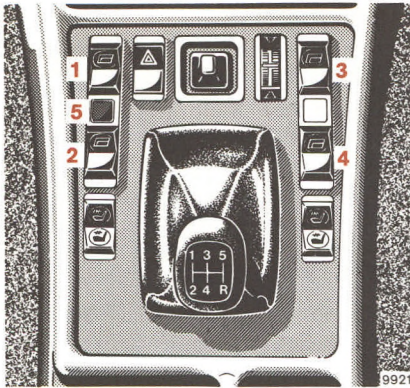

Power Windows

Switch group for power windows:

- 1 front, left
- 2 rear, left
- 3 front, right
- 4 rear, right
- 5 Safety switch

The power windows can only be operated with the steering lock in position 1 or 2.

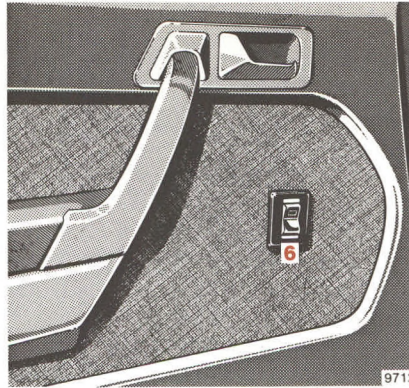

Shelf below Rear Window

The shelf below the rear window should not be used to carry objects. This will prevent such objects from being thrown about and injuring vehicle occupants during an accident or sudden maneuver.

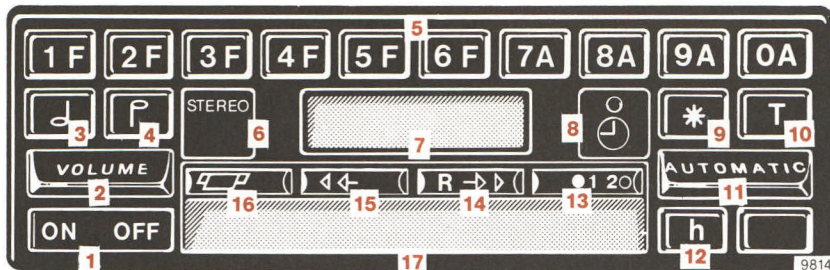

Electronic Radio

- | | |
|---|---|
| <p>1 On/Off switch ON OFF</p> <p>2 Volume control VOLUME</p> <p>3 Bass control B</p> <p>4 Treble control T</p> <p>5 Push buttons for AM/FM band selection, station frequency selection, station presetting and clock setting 1 F through 0 A</p> <p>6 Stereo indicator lamp STEREO</p> <p>7 Digital display for station frequency, station push button number, AM/FM band 07:30 and time display</p> | <p>8 Recessed button for setting time ⌚</p> <p>9 Function control button *</p> <p>10 Timer button to control switch-on time of radio T</p> <p>11 Automatic or manual search station seeker bar AUTOMATIC</p> <p>12 Time display button h</p> <p>13 Cassette track selector switch and track indicator ● 1 2 ◁ ▷</p> <p>14 Fast tape rewind locking button R ▷▷</p> |
|---|---|

- 15 Fast tape forward locking button **◁◁**
- 16 Cassette eject button **▶▶**
- 17 Cassette door **|||||**
- To turn the radio on or off, the steering lock key must be in position 1 or 2.

To turn the radio ON

Press “ON” side of **ON OFF** switch. The radio will begin operating on the last station, volume and tone setting stored before the last turn off.

The radio can also be turned on by inserting a tape cassette through the cassette door.

To turn the radio OFF

Press the “OFF” side of the **ON OFF** switch.

Volume adjustment

To reduce volume, press volume switch **VOLUME** downward; to increase volume, press volume switch **VOLUME** upward.

A fader control, installed in the center console, allows for balancing the sound level between the front and rear speakers.

To adjust the tone characteristic

To set the radio to a “flat” tone setting (bass and treble at mid-range setting), briefly press both tone controls **B** **P** simultaneously.

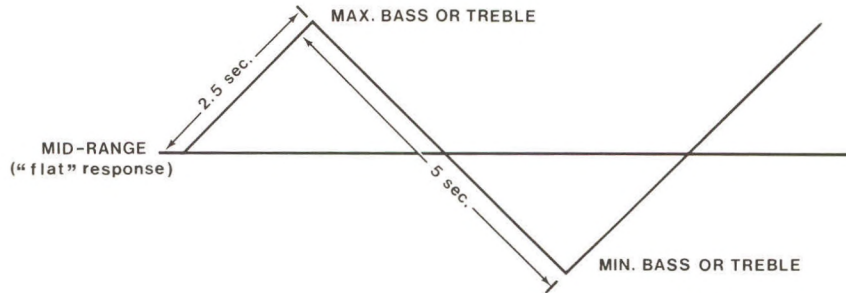

Upon pressing either tone button, the tone level for that function (either bass **B** or treble **P**) will begin increasing. It stops increasing when the button is released or when the maximum tone level is reached (approx. 2.5 seconds).

After reaching the maximum tone level, the tone control will stay at that level unless the tone button is released and pressed again.

Once the tone button is pressed again the tone level will start decreasing. It will stop decreasing when the button is released or when the minimum tone level is reached (approx. 5 seconds).

After reaching the minimum tone level, the tone control will stay at that level unless the tone button is released and pressed again. After pressing the tone button again the tone level will begin to increase and the cycle is repeated.

Note: It takes approx. 5 seconds to go from minimum tone level to maximum tone level.

To select AM or FM

Press any of the buttons marked **1F** through **6F** to tune the radio to the FM band.

Press any of the buttons marked **7A** through **0A** to tune the radio to the AM band.

To tune to a station

Stations can be tuned in by using automatic search, direct frequency dialing, manual tuning, or by preset push buttons. The frequency of the station selected is indicated on the digital display.

Automatic station search

Switch to the wave band desired by pressing any of the following buttons:

for FM, buttons **1F** through **6F**,
for AM, buttons **7A** through **0A**.

By pressing the automatic station seeker bar **AUTOMATIC** upward the radio will search for stations in ascending frequencies, by pressing down it will do so in descending frequencies. The direction of automatic searching can be reversed by pressing the bar **AUTOMATIC** in the respective direction. In order to arrive at a desired station without stopping, the bar has to be held in the desired direction.

The radio is programmed to automatically search the entire band at three sensitivity levels. During its first sweep, only the most powerful stations received will be selected and locked in. During the next sweep, the less powerful and during the third sweep, the weak stations will also be locked in.

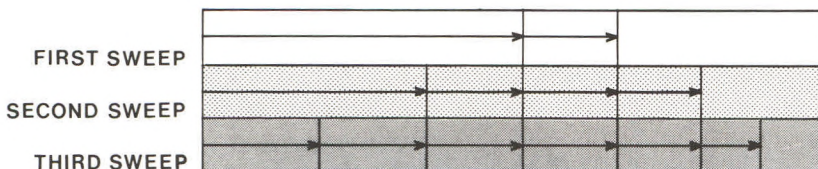

If the station seeker bar is activated within 8 seconds after the radio is tuned to a station, then the search operation will be continued at the same sensitivity level. If 8 seconds are exceeded, the radio will revert to searching only the most powerful stations.

Direct frequency dialing

In order to select a station with a known frequency, select the wave band, press the function control button ***** and then enter the frequency by pressing the corresponding push buttons.

Example:

Press any button marked
Press the function button
Enter frequency by pressing

FM 98.5 MHz	AM 1050 KHz
1 F through 6 F	7 A through 0 A
*	*
9 A , 8 A , 5 F	1 F , 0 A , 5 F , 0 A

When dialing a frequency directly, the number of the push buttons is not displayed on the panel. The wave band is indicated by showing "MHz" for FM or "KHz" for AM.

Note:

All AM stations have allocated frequencies ending with a "0".

All FM stations have allocated frequencies ending with an odd (un-even) digit after the decimal point.

Broadcasters sometimes may not give their exact frequency but the next closest even number.

US radio frequency ranges:
AM 540–1600 KHz
FM 88.1–107.9 MHz

Manual tuning (used to fine tune a station or for manual scanning)

After selecting the desired AM or FM wave band, press the function control button *****.

Press automatic station seeker bar **AUTOMATIC** (up or down) and hold. The frequency will increase or decrease respectively in increments of 0.1 MHz for FM or 1.0 KHz for AM. Release the button when the desired station is tuned in.

Unless the automatic station seeker bar **AUTOMATIC** is activated within 8 seconds after pressing the function control button *****, the manual tuning will automatically be deactivated.

Safety Note

To avoid distraction from the vehicle's operation and the road, it is recommended that the driver NOT perform any manual tuning operations while the vehicle is in motion. Use the automatic station search operation or preset stations instead.

Push button tuning

Six FM stations and four AM stations can be stored in memory and recalled by pressing the appropriate buttons marked **1F** through **6F** for FM or **7A** through **0A** for AM stations.

To store stations in memory

Any FM station frequency indicated on the digital display can be stored on any button marked **1F** through **6F** by depressing the button desired and holding it until the display has changed from the "old" setting to a "blank" and then to the new frequency to be stored.

Showing the "old" setting first allows for reconsideration of the decision to store. If it is desirable to leave the "old" frequency in memory rather than exchanging it with the "new" one, quickly release the button. The "old" frequency will remain in memory.

Any AM station can be stored similarly on any button marked **7A** through **0A**.

Stereo reception

The stereo indicator symbol **STEREO** lights up if a stereo program is received.

The radio is equipped with an automatic stereo/mono switch that electronically switches to mono for clear reception if a weak signal is received. A special circuit provides for a smooth change-over rather than a hard sudden switching, thereby reducing noise and interference.

The stereo indicator will remain lit even if the receiver has changed to the mono mode and will turn off at an antenna signal considered insufficient to provide acceptable reception quality.

Important! Although FM is normally static free, reception can be limited by geographic and atmospheric conditions, station strength and distance from transmitter. Buildings or other obstructions can cause momentary static, flutter or station swapping. If good reception cannot be obtained, tune to a stronger station.

Tape Cassette playback

It is recommended to use only good quality cassettes with a playback time of not more than 60 to 90 minutes (C 60) or (C 90).

To start playback, insert a cassette (tape side first, side "I" or "A" facing up) through the cassette door. Push the cassette in until it is locked in its playing position.

When the end of one playing side is reached, the unit switches automatically to reverse for playing the second track.

The tape track can be selected by depressing the cassette track switch button **1 2 3**. The built-in indicators show which track of the cassette the unit is playing back.

To stop playback, press the eject button **EJECT**. The unit will automatically eject the cassette and switch to radio reception.

For fast tape rewind press the fast rewind button **REWIND**. The button will lock into position until the end of the tape is reached or until the eject **EJECT** or fast forward **FF** button is activated.

Accordingly, for fast forward of the tape, press the fast forward button .

When the radio is turned off by pressing the "OFF" side of the **ON OFF** switch or by turning the steering lock key to the off, the cassette will automatically be ejected.

Care and maintenance

To avoid deterioration of the tone quality, occasionally clean the tape head with the special cleaner supplied in your glove compartment or available through your dealer.

To set clock

Turn steering lock key to position 1 or 2.

Briefly press recessed time set button  by using a pencil or ballpoint pen.

Enter the time at which you want to start the clock by sequentially pressing four of the top row push buttons **1F** through **0A**. The time entered will be displayed.

Note: This is a 24 hour clock and time must be entered in all four digits. A 24 hour clock counts time from midnight to midnight, that is

24 hours. A time of 4:28 PM is indicated by this clock as 16:28 hours (12 plus 4:28 hours).

Example 1: To enter 7:30 AM, press buttons **0A**, **7A**, **3F**, **0A**

Example 2: To enter 4:28 PM, press buttons **1F**, **6F**, **2F**, **8A**

The time entered is now stored. To start the clock in accordance with a time signal or other time reference, again briefly press the recessed time set button .

A colon sign will appear between the second and third digits **07:30**, to indicate that the clock is activated. With the radio switched off, the time will be indicated on the digital display. When the radio is switched on, the digital display will indicate the frequency which the radio is tuned to.

To display time

Briefly press the call button **h**. The time will be displayed for a few seconds.

To use the timer **T**

By using the timer **T**, the radio can be automatically turned on at a preset time. In order to set the timer

T, the steering lock key must be in position 1 or 2. The timer **T** can only turn the radio on with the steering lock key in position 1 or 2.

Setting the timer

1. Press button **T**.
2. Enter the time for automatic turn-on by sequentially pressing four of the top row push buttons **1F** through **0A** for the 24-hour time desired.
3. Press button ***** to activate the timer. Activation of the timer is indicated by a colon between the second and third digits of the time.

Note: To activate this function each day, press buttons **T** and ***** with the key in steering lock position 1 or 2.

The radio will then turn on at the preset time.

Whenever you wish to verify the time at which the timer is set, press button **T**. The time will be indicated in the digital display. After a few seconds, the display will switch back to the station frequency. To change the timer to a new setting, repeat steps 1 through 3.

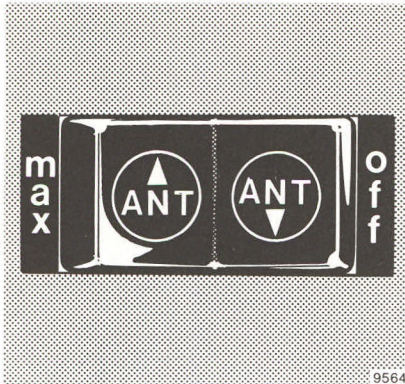

Automatic Antenna

The antenna switch can be actuated with the radio switched on and the key in steering lock positions 1 or 2.

- If the antenna switch is in the center position, the antenna extends automatically to medium height,
- if the antenna switch is engaged in the "max." position, the antenna extends fully,
- if the antenna switch is engaged in the "off" position, the antenna will not extend or will retract completely.

The height of the antenna can be adjusted to any intermediate position by actuating the antenna switch:

- If the antenna switch is in center position, the antenna will extend to medium height. The antenna can be further extended or retracted to any height by rocking the switch (not engaging it).
- If the antenna is to be retracted, e.g. for playing cassettes, engage switch in "off" position.

When the key is turned to steering lock position 0 or the radio is turned off, the antenna will retract completely.

Driving

Parking Brake	52
Starting and Shifting Gears	52
Manual Transmission	52
Recommended Shift Points for Manual Transmission	52
Automatic Transmission	53
Cruise Control	55
ABS-Brake System (Anti-Lock Brake System)	56
Brake Pad Wear Indicator Lamp	57
Brake Fluid	57
Charge Indicator Lamp	57
Oil Pressure Gauge	57
Low Engine Oil Level Indicator Lamp	57
Fuel Reserve Warning Lamp	58
Coolant Temperature Gauge	58
Low Engine Coolant Level Indicator Lamp	58
Low Windshield Washer Level Indicator Lamp	58
Outside Temperature Indicator	58
Engine Oil Consumption	58
Emission Control	59
High Altitude Correction Device	59
Traveling Abroad	59
Winter Driving	60
Tire Chains	60

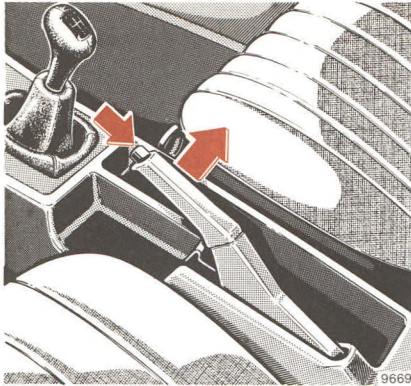

Parking Brake

Pull up parking brake lever. The brake indicator lamp on the instrument cluster will come on when the key is in steering lock position 2.

To release the parking brake, slightly pull up lever, push in lock button at the grip then lower it completely. The indicator lamp on the instrument cluster must go out when the lever is down.

Starting and Shifting Gears

Warning!

Keep driver's foot area clear at all times. Objects stored in this area may cause impairment of pedal movement.

Test the service brake before driving off.

Warm up the engine smoothly. Do not place full load on the engine until the operating temperature has been reached.

When taking off on a slippery surface, do not allow one driving wheel to spin for an extended period.

Manual Transmission

See figure for gearshift lever positions corresponding to the individual gears.

Shift into reverse gear only with the vehicle at a standstill; for this purpose press shift lever down and engage reverse gear shortly after de-clutching.

Do not exceed the maximum speed in the individual gears. See line markings on the speedometer.

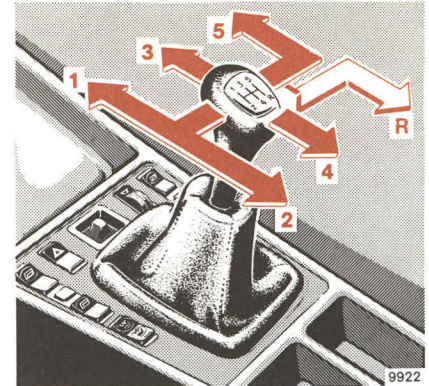

Note:

When vehicle is parked, be sure to engage first or reverse gear and set parking brake.

Recommended Shift Points for Manual Transmission

To obtain good fuel economy, the following shift points are recommended:

Shift

from 1st to 2nd at 21 km/h/13 mph
from 2nd to 3rd at 39 km/h/24 mph
from 3rd to 4th at 53 km/h/33 mph
from 4th to 5th at 79 km/h/49 mph.

Automatic Transmission

The automatic transmission simplifies the handling of the vehicle. The individual gears are shifted automatically dependent upon selector lever position, vehicle speed and accelerator position.

Hint:

When the vehicle is parked or being worked on with engine running, be sure to set parking brake and that selector lever is in position "P".

Driving:

Shift selector lever to the desired driving position only when the engine is idling and the service brake is applied. Do not release the brake until ready to drive. The vehicle may otherwise start creeping when the selector lever is in a driving position.

Accelerator position

Partial throttle = early upshifting = normal acceleration

Full throttle = later upshifting = maximum acceleration

Depressing the accelerator beyond full throttle to kickdown position means downshifting to the next lower gear and thus maximum acceleration. If you ease up on the accelerator after having attained the desired speed, the transmission will shift up again.

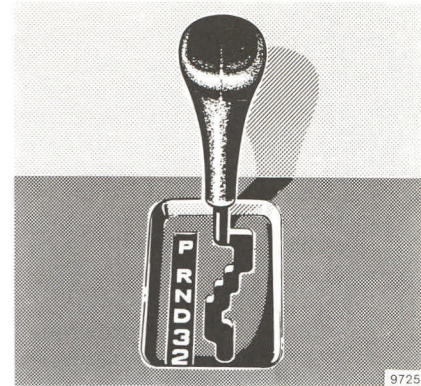

Selector lever positions

The automatic gear shifting process can be adapted to specific operating conditions by means of the selector lever.

"P" Parking lock.

The parking lock is an additional safeguard when parking the vehicle. Engage only with the car stopped.

"R" Reverse gear.

Shift reverse gear only with the car stopped.

“N” Neutral.

No power is transmitted from the engine to the rear axle. When the brakes are released, the vehicle can be moved freely (pushed, towed or tow-started). Do not engage “N” when driving except when the vehicle is in danger of skidding (e.g. on icy roads, see page 14).

“D” Drive.

Automatic upshifting to top gear. Position “D” affords optimum driving characteristics under all normal operating conditions.

“3” Slope.

Upshift to 3rd gear only. Suitable for medium range up or downgrades.

“2” Low.

Upshift to 2nd gear only. For driving in mountainous regions. Since transmission will not shift up any further, this gear selection will make use of the engine’s braking power.

Important!

Do not exceed the speed limits for individual gear selections, which are correspondingly indicated by marks on the speedometer.

Do not attempt downshifting to a lower gear (braking effect) unless the speedometer needle is below the speed-limit-mark of that particular gear range. Over-revving could result in damage to the engine.

On slippery road surfaces, it is not recommended to downshift to obtain braking action.

Trailer operation

To prevent the engine from laboring at low RPMs, do not allow the engine speed to drop too low on uphill gradients. Depending on the degree of the incline, shift selector lever to positions “3” or “2” early enough to maintain engine RPMs within best torque range.

Stopping

For brief stops, e.g. at traffic lights, leave the transmission engaged and control vehicle with the service brake.

For longer stops with the engine idling, shift into “N” or “P”.

When stopping the car on a slope, do not hold it with the accelerator, use the brake. This avoids unnecessary transmission heat-up.

Maneuvering

To maneuver in tight areas, e.g. when pulling into a parking space, control the car speed by gradually releasing the service brake.

Accelerate gently and do not pump the accelerator. To rock a car out of soft ground (mud or snow), alternately shift from forward to reverse while applying partial throttle.

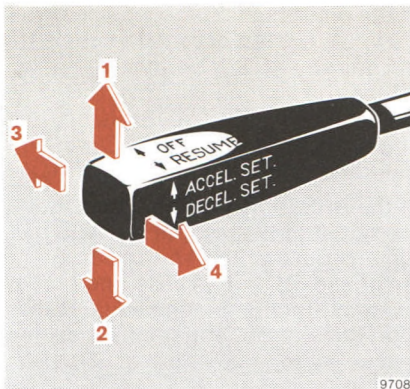

Cruise Control

Any given speed above approximately 40 km/h/25 mph can be maintained with the cruise control by operating the switch.

- 1 Setting (briefly push switch)
Accelerating (hold switch)
- 2 Setting (briefly push switch)
Decelerating (hold switch)

Normally the vehicle is accelerated to the desired speed with the accelerator. Speed is set by briefly pushing the switch to position 1 or 2. The accelerator can then be released.

The speed can be increased (e.g. for passing) by using the accelerator. As soon as the accelerator is released, the previously set speed will be resumed automatically.

If a set speed is to be increased or decreased slightly, e.g. to adapt to the traffic flow, hold switch in position 1 or 2 until the desired speed is reached. When the switch is released, the newly set speed remains.

3 Cancelling

To cancel the cruise control, briefly push lever to position 3. When you step on the brake or clutch pedal or the vehicle speed falls below approx. 40 km/h/25 mph, for example when driving upgrade, the cruise control will be cancelled.

4 Resume

If the lever is briefly pushed to position 4 when driving at a speed exceeding approximately 40 km/h/25 mph, the vehicle resumes the speed which was set prior to the cancellation of the cruise control. The last memorized speed is cancelled when the key in the steering lock is turned to position 1 or 0.

Note:

If the engine does not brake the vehicle sufficiently while driving on a downgrade, the speed you set on the cruise control may be exceeded and you may have to step on the brake pedal to slow down. As soon as the grade eases, the cruise controlled speed will again be maintained as long as the brakes were not previously applied.

Important:

Only use the cruise control if the traffic conditions make it advisable to travel at a steady speed.

Position "Resume" should be engaged only if the driver is fully aware of the previously set speed and wishes to resume this particular preset speed.

In the case of manual transmissions, the vehicle maximum speed in the individual gears should not be exceeded. See line markings on the speedometer. In the case of automatic transmissions, the transmission selector lever must not be shifted to position "N" when driving with the cruise control engaged as otherwise the engine will overrev.



ABS-Brake System (Anti-Lock Brake System)

You can tell if your vehicle is equipped with an ABS by the yellow indicator lamp with the letters “ANTILOCK” in the instrument cluster (see page 11).

The ABS prevents the wheels from locking up above a speed of approx. 3 km/h / 2 mph independent of road surface conditions. It is necessary, however, that a speed of approx. 8 km/h / 5 mph has been exceeded at least once after start-up.

At the instant one of the wheels is about to lock up, you will notice a slight vibration in the brake pedal and the vehicle, indicating that the ABS is enhancing the driver's ability to control the vehicle by preventing the wheels from locking. This also

indicates that the ABS is in the regulating mode. On slippery road surfaces, the ABS will already respond with a slight brake pedal pressure. The pulsating brake pedal can be an indication of hazardous road conditions, and you may want to take extra care driving.

Warning!

Always keep a safe distance from the vehicle in front of you. Only a safe, attentive and skillful driver can prevent accidents. The ABS cannot prevent accidents including those resulting from excessive speed in turns or following a vehicle too closely.

The ABS indicator lamp in the instrument cluster comes on with the key in steering lock position 2 and should go out with the engine running.

If the charging voltage falls below 10 volts, the indicator lamp comes on and the ABS is switched off. When the voltage is above this value again, the indicator lamp should go out and the ABS will be operational.

If the ABS indicator lamp does not go out, it indicates that the ABS has detected a malfunction and has switched off. In this case, the brake system functions in the usual manner, but without anti-lock assistance. We recommend that you visit an authorized MERCEDES-BENZ dealer as soon as possible to have the system checked.

Brake Pad Wear Indicator Lamp

The brake pad wear indicator lamp in the instrument cluster stays on when the key in the steering lock is turned to position 2 and it must go out when the engine is running. If the indicator lamp lights up during braking, this shows that the front wheel brake pads are worn down.

Have the brake system checked at an authorized MERCEDES-BENZ dealer as soon as possible.

Brake Fluid

Brake fluid should be changed once a year, preferably in spring.

Only use brake fluid recommended by us. For further information, refer to "Fuels, Coolants, Lubricants, etc."

The low brake fluid indicator lamp will come on if insufficient brake fluid is in the reservoir. (The key must be in steering lock position 2, and the parking brake released.)

When the minimum mark on the reservoir is reached, have the system checked (brake lining thickness, leaks).

Charge Indicator Lamp

Should the charge indicator lamp fail to come on prior to starting when the key is in steering lock position 2 or should it fail to go out after starting or during operation, this indicates a fault which must be repaired at an authorized MERCEDES-BENZ dealer as soon as possible.

When the charging indicator lamp glows while the engine is running, the V-belt may have been broken (which also makes the water pump inoperative). This may cause overheating and damage to the engine. In this case the V-belt must be renewed at once.

Oil Pressure Gauge

The oil pressure at idle speed may drop to 0.3 bar/4.4 psi if the engine is at operating temperature. This will not jeopardize its operational reliability. Pressure must, however, rise immediately upon acceleration.

Low Engine Oil Level Indicator Lamp

The indicator lamp comes on with the key in steering lock position 2 and should go out when the engine is running.

If it comes on with the engine running and at operating temperature, the oil level has dropped to the minimum mark on the dipstick. If this occurs, the indicator lamp will first come on intermittently and then stay on if the oil level drops further and oil needs to be added. We recommend that you add 1 l/ 1.1 US qt if the indicator lamp stays on.

In addition to the indicator lamp, the engine oil level should be periodically checked with the dipstick, for example after a fuel fill-up, or before a long trip (see page 64).

Fuel Reserve Warning Lamp

The fuel reserve warning lamp will come on when the key is turned to steering lock position 2, and will go out after the engine is running.

If the warning lamp stays on after the engine starts, or comes on while driving, it indicates that the fuel level is down to the reserve quantity.

Coolant Temperature Gauge

If the antifreeze mixture is good to $-30^{\circ}\text{C}/-22^{\circ}\text{F}$ the boiling point of the coolant in the pressurized cooling system of your vehicle is approx. $125^{\circ}\text{C}/257^{\circ}\text{F}$ (see also "Fuels, Coolants, Lubricants, etc.").

During severe operating conditions and stop-and-go city traffic the coolant temperature must not rise above the red marking.

Low Engine Coolant Level Indicator Lamp

The indicator lamp comes on with the key in steering lock position 2, and should go out when the engine is running.

If it comes on with the engine running, the coolant has dropped below the required level. You should then have the engine cooling system checked for signs of leakage and have it refilled as soon as possible (see page 63).

Low Windshield Washer Level Indicator Lamp

The indicator lamp comes on with the key in steering lock position 2 and should go out when the engine is running.

If it comes on with the engine running, the level of the reservoir has dropped to about $\frac{1}{4}$ of the total volume and should be filled again with washer fluid to which about 3 capfuls of MB auto-shampoo have been added.

Outside Temperature Indicator

The temperature sensor is attached to the front bumper behind the license plate base plate. Due to its location, the sensor can be affected by road or engine heat during idling or slow driving. This means that the accuracy of the displayed temperature can only be verified by comparison to a thermometer located next to the sensor, not by comparison to external displays (i.e., bank signs, etc.).

Engine Oil Consumption

Engine oil consumption can only be determined after a certain mileage has been covered. During the break-in period, higher oil consumption may be noticed and is normal.

Emission Control

Certain systems of the engine serve to keep the toxic components of the exhaust gases within permissible limits required by law. (Nevertheless, we urgently advise you not to let the engine run in a closed garage.) These systems, of course, will function properly only when maintained strictly according to factory specifications. Any adjustments on the engine should, therefore, be carried out only by qualified MERCEDES-BENZ technicians. The adjustments of the engine should not be altered in any way. Moreover, the specified service and maintenance jobs must be carried out regularly according to MERCEDES-BENZ servicing requirements. For details refer to the Maintenance Booklet.

High Altitude Correction Device

The engine is equipped with an automatic high altitude correction device.

Traveling Abroad

Abroad, there is a widely-spread MERCEDES-BENZ service network at your disposal. If you travel into areas which are not listed in the index of your dealer directory, you should request pertinent information from your dealer.





Winter Driving

Have your car winterized at an authorized MERCEDES-BENZ dealer before the onset of winter.

- Engine oil change: If “year-round” multigrade engine oil is not used, be sure to use an SAE grade based on ambient temperature. For recommended engine oil viscosities refer to “Fuels, Coolants, Lubricants, etc.” and last page.
- For diesel fuels, refer to page 94 and last page.
- Anticorrosion/antifreeze in the coolant: Check anticorrosion/antifreeze protection periodically. For capacity refer to “Fuels, Coolants, Lubricants, etc.”.

- Additive in the windshield washer system: Add windshield washer solvent to the water in the windshield washer system.
- Test battery: Battery capacity drops with decreasing ambient temperature. A well charged battery ensures that the engine can always be started, even at low ambient temperatures.
- Tires: We recommend M+S radial tires on all wheels for the winter season. Observe permissible maximum speed for M+S radial tires and the legal speed limit.

Tire Chains

Use only tire chains that are tested and recommended by us. Any authorized MERCEDES-BENZ dealer will be glad to advise you on this subject.

Chains should only be used on the rear wheels. Adhere to the manufacturer’s mounting instructions.

After driving a short distance retighten the mounted chains.

Tire chains should only be driven on snow at speeds not to exceed 50 km/h/30 mph. Remove chains as soon as possible when driving on roads without snow.

For tips on driving on slippery winter roads refer to page 14.

Practical Hints

Hood	62
Checking Coolant Level	63
Adding Coolant	63
Engine Oil Level Check	64
Fluid Level-Automatic	
Transmission	65
Turning off Engine Manually	66
Bleeding of Fuel System	66
First Aid Kit	67
Spare Wheel, Jack, Vehicle	
Tool Kit	67
Wheels, Tires	68
Changing Wheels	69
Tire Inflation Pressure	70
Fuses	71
Battery	71
Headlamp Adjustment	72
Replacing Bulbs	72
Emergency Operation of	
Sliding Roof	75
Unlocking of Fuel Filler Flap	75
Tow-starting and Towing	
the Vehicle	76
Jump Starting	77
Cleaning and Care of	
the Vehicle	78
Safety Head Restraints	81
Rear Seat Cushion	82
Ash tray	82
Roof Rack	83
Spare Parts Service	83
Layout of Poly V-belt Drive	83

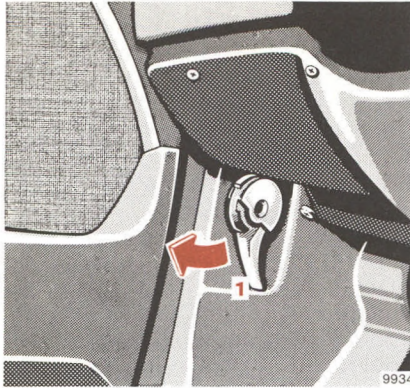

Hood

To open:

Pull hood release lever (1) under the LH side of instrument panel to unlock the hood. This will cause handle (2) to come out of radiator grill (it may be necessary to lift hood up slightly).

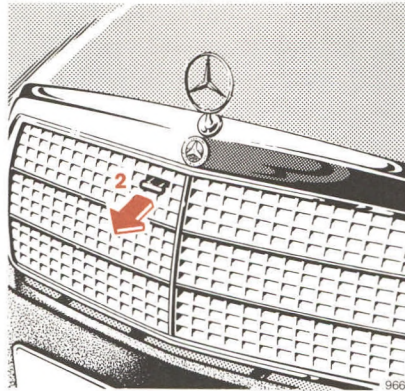

Pull handle (2) completely out of radiator grill and open hood to approximately 45° (windshield wiper arm must not be folded out).

To close:

Push hood down on left side (viewed in driving direction). Make sure that hood is securely locked.

Warning!

Stay clear of moving parts when the hood is open and the engine is running.

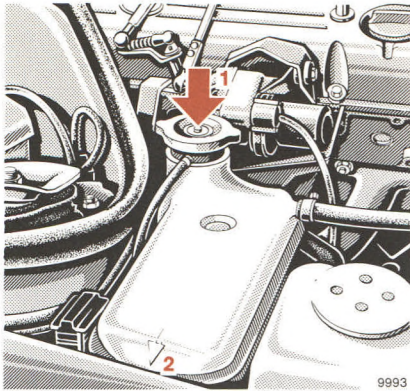

- 1 Coolant filler cap
- 2 Marking for coolant level

Checking Coolant Level

The coolant level can be checked visually at the transparent coolant reservoir.

To check the coolant level, the vehicle must be parked on level ground.

The coolant level must reach:

The marking (2, arrow) on the reservoir when the engine is cold.

Approx. 1 cm/0.4 in higher when the engine is at operating temperature.

Adding Coolant

If a small amount of coolant has to be added (due to evaporation of water), plain water can be used.

If a larger quantity of coolant has to be added, a 50/50 mixture of water and anticorrosion/antifreeze should be used.

Warning!

Do not remove pressure cap on coolant reservoir if engine temperature is above 90° C/194° F. Allow engine to cool down before removing cap. The coolant reservoir contains hot water and is under pressure.

Using a rag, turn cap to first notch to relieve excess pressure. If opened immediately, hot scalding fluid and steam will be blown out under pressure.

The drain plugs for the cooling system are located on the right-hand side of the engine block and the bottom of the radiator.

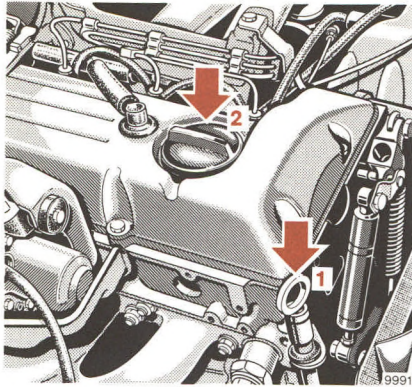

- 1 Dipstick
- 2 Oil filler cap

Engine Oil Level Check

The engine oil level should be checked when the oil is warm and with the vehicle on level ground. The engine must be at operating temperature for some time. After stopping the engine, wait a few minutes (i.e. after a fuel fill-up) and then check the level.

Wipe the dipstick clean before checking.

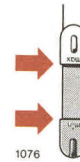

Add oil, if needed, only to the upper mark (max). Do not overfill the engine.

For viscosity and capacity, see "Fuels, Coolants, Lubricants, etc." and last page.

For low engine oil level indicator lamp, see page 57.

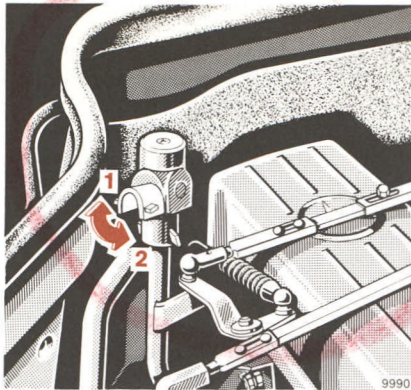

Fluid Level – Automatic Transmission

At regular intervals and prior to a long trip, check automatic transmission fluid level and engine oil level.

Check transmission fluid level with the engine idling, parking brake engaged and selector lever in position “P”. The vehicle must be parked on level ground. Prior to the check, allow engine to idle for approx. 1 to 2 minutes.

Measure fluid level with the dipstick completely inserted and the locking lever released (1).

Extreme cleanliness must be observed!

To wipe the dipstick, use a clean, lintfree cloth.

To fill the transmission with fluid, pour it through a fine-mesh filter into the dipstick opening. Even the slightest impurity may cause operational troubles.

The fluid level in the transmission is dependent upon its temperature.

The maximum and minimum oil level marks on the dipstick are applicable references only if the transmission fluid has reached its normal operating temperature of 80° C/ 176° F.

If transmission fluid cools down to 20–30° C/68–86° F, which is the normal shop temperature range, then the maximum fluid level will be approximately 12 mm/0.5 in below the minimum mark on the dipstick. We stress this point because a fluid change is normally performed when the transmission fluid has cooled down to shop temperature.

The fluid level must not exceed the dipstick maximum mark with the fluid at operating temperature. Drain or siphon off excess fluid, if required.

Then push dipstick all the way in and swing locking lever downwards (2).

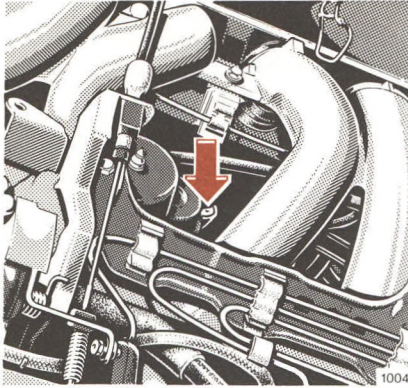

Turning off Engine Manually

If the engine continues to run after the key is turned to steering lock position 0, open the hood and push down the lever marked "STOP" until the engine stops running.

Using an extension such as a pen or screwdriver should make it easier to push the "STOP" lever down.

Bleeding of Fuel System

The fuel system is a self bleeding system. Turn the key in steering lock fully to the right and crank engine (for up to one minute maximum). Push accelerator pedal to the floor while cranking engine. Only release key after engine fires evenly.

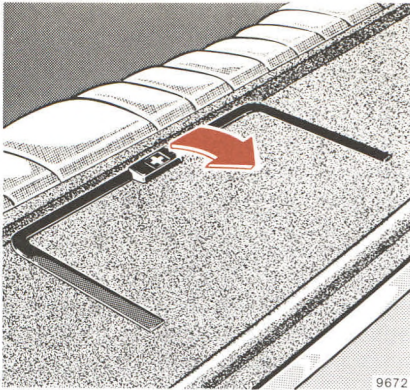

First Aid Kit

The first aid kit is stored in the hat shelf at the rear.

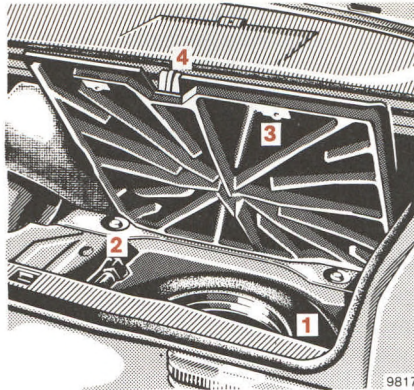

Spare Wheel, Jack, Vehicle Tool Kit

The spare wheel (1), jack (2) and tool kit are stored in a compartment below a hinged door (3) in the trunk floor.

To raise the door, roll back the floor mat and engage holding strap (4) in the trunk lid.

The hinged door can also be removed completely by raising the door to approximately 45°, lifting it slightly at the hinged side and pulling it out to the rear.

Warning!

Use the jack only to lift the vehicle during a wheel change. Never get beneath the vehicle while it is supported only by the jack. Use jack stands to work under the car.

Wheels, Tires

Replace wheels or tires with the same designation, manufacturer and type as shown on the original part.

See any authorized MERCEDES-BENZ dealer for information on tested and recommended wheels and tires for summer and winter operation. They can also offer more advice concerning tire service and purchase.

Front tires should be replaced in sets. If possible, the spare tire should be used on the rear wheels. We recommend that you break in new tires for approximately 100 km/60 miles at moderate speed.

After a wheel change, it is imperative that the wheel mounting bolts be retightened after approx. 800 km/500 miles. On new vehicles retightening is carried out in the

course of the 1st inspection. Retightening is also necessary when new wheels are fitted at a later date, e.g. when the spare wheel is used for the first time or when a new set of wheels with M + S tires is fitted.

For tire specifications, refer to "Technical Data".

Rotating wheels:

The wheels can be rotated according to the degree of tire wear while retaining the same sense of rotation. Rotating, however, should be carried out before the characteristic tire wear pattern (shoulder wear on front wheels and tread center wear on rear wheels) becomes visible at a mileage of 5000–10000 km/3000–6000 miles as otherwise the driving properties deteriorate.

Slow leaking air (e.g. due to a nail in the tire) may cause damage to the tire such as tread separation. Regular tire pressure checks at intervals of no more than 14 days are therefore essential. For the tire pressure checks, keep in mind that hot tires show higher pressure than cold tires. See tire pressure chart on last page.

Should the tire pressure decrease constantly, check whether foreign objects have penetrated the tire or if rim or valve allow the air to leak.

Thoroughly clean the inner side of the wheels any time you rotate the wheels or wash vehicle underside.

Dented or bent rims cause tire pressure loss and damage to the tire beads. For this reason, check rims for damage at regular intervals. The rim flanges must be checked for wear before a tire is mounted. Remove burrs, if there are any.

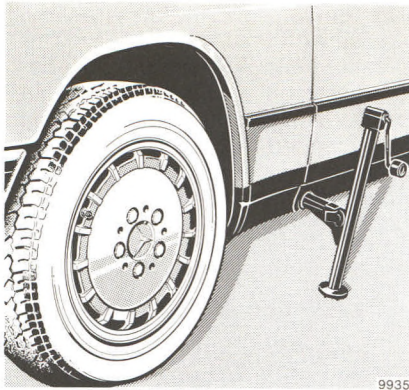

Changing Wheels

1. Set parking brake.
2. With manual transmission, shift gear shift lever to 1st or reverse gears respectively, with automatic transmission, move selector lever to position "P".
3. Prevent vehicle from rolling away by blocking wheels with wheel chocks: When changing a wheel on a hill, place chocks behind each wheel of the axle opposite to the axle to be worked on; on a level road, place one chock in front and one behind of the wheel that is diagonally opposite to the wheel being changed.
4. Using the combination wrench, loosen but do not yet remove the wheel bolts.
5. Remove protective cap from the jack support tube. (The tube openings are located directly behind the front wheel housings and in front of the rear wheel housings.)
6. Insert jack arm fully into the tube hole up to the stop. Position the jack so that it will always be vertical as seen from the side, even on inclines. Jack up the vehicle until the wheel is clear off the ground.
7. Then unscrew wheel bolts completely. Keep bolt threads protected from dirt and sand. While removing last bolt, hold wheel against axle to avoid paint damage on rim.
8. Remove wheel.
9. Screw the alignment stud, which comes with the spare tire, into the upper threaded hole of the hub prior to installing wheel.
10. Adjust the jack to allow the wheel to be slipped on without being lifted.
11. Install spare wheel (valve in bottom position) on wheel hub. Insert wheel bolts and tighten them slightly. To avoid paint damage, place wheel flat against hub and hold it there while installing first wheel bolt. Unscrew the alignment stud to install the last wheel bolt.
12. Lower car, remove jack and place cap into the jack support tube. Tighten the five bolts evenly, always skipping one, until all bolts are tight. Observe a tightening torque of 110 Nm/ 80 lb-ft.
13. Correct tire pressure.

Tire Inflation Pressure

A table (see fuel filler flap or last page) lists the tire inflation pressures specified for summer and winter tires as well as for the varying operating conditions.

Important!

Tire pressure differs by approx. 0.1 bar/1.5 psi per 10° C/18° F of air temperature change. Keep this in mind when checking tire pressure inside a garage – especially in the winter.

Example:

Room temperature = approx.
+ 20° C/+ 68° F

Ambient temperature = approx.
0° C/+ 32° F

Adjusted air pressure = specified
air pressure + 0.2 bar/3 psi.

Tire pressures listed for light loads are minimum values offering high driving comfort. Increased inflation pressures for heavy loads produce favorable handling characteristics with lighter loads and are perfectly permissible. The ride of the vehicle, however, will become somewhat harder.

Tire temperature and pressure increase with the vehicle speed. Tire pressure should therefore only be corrected on cold tires. Correct tire pressure in hot tires only if pressure has dropped below the data listed in the table and the respective operating conditions are taken into consideration.

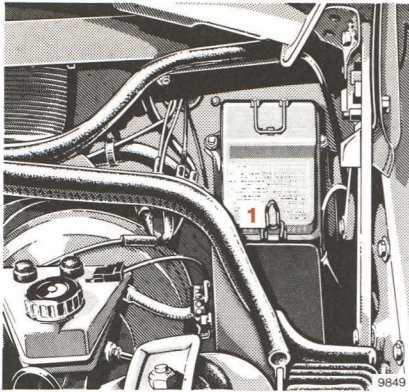

Fuses

The fuse box is located in the engine compartment.

All electrical circuits are numbered and protected by a fuse. The numbers of the circuits and all power consumers in each circuit are listed inside the fuse box cover.

To exchange a fuse, remove clamp (1) and remove fuse box cover.

Before replacing a blown fuse, determine the cause of the short circuit.

Spare fuses are furnished inside the fuse box. Observe amperage and color of fuse.

Always use a new fuse for replacement. Never attempt to fix or bridge a blown fuse.

After replacing a fuse, replace fuse box cover and secure with clamp (1).

Battery

Check fluid level in each cell approximately every 4 weeks, and more frequently during the summer and in hot climates.

Refill battery only with distilled water. Do not use metal funnels or push through the overfill-protection diaphragms in filler holes.

The battery is completely filled when the water stops draining through the overfill-protection diaphragm.

To check the battery charge with a hydrometer, push its tip through the overfill-protection diaphragm and take the electrolyte sample.

Coat battery terminal clamps with acidproof grease. Keep battery clean and dry.

The service life of the battery is also dependent on its condition of charge. It must be maintained sufficiently charged for the battery to last an optimum length of time.

Therefore, we recommend that you have the battery charge checked frequently if you use the vehicle mostly for short distance trips, or if it is not used for long periods of time.

Only charge battery with a battery charger when it is disconnected from the vehicle electrical circuit.

Warning!

Battery fluid contains sulfuric acid. Do not allow this fluid to come in contact with eyes, skin, or clothing.

In case it does, immediately flush affected area with water, if necessary seek medical help.

A battery will also produce hydrogen gas, which is flammable and explosive. Keep flames or sparks away from battery, i.e. improper connection of jumper cables, cigarette smoking, etc..

While the engine is running the battery terminal clamps must not be loosened or detached as otherwise the alternator and other electronic units would be damaged.

Only tow vehicle with the battery connected.

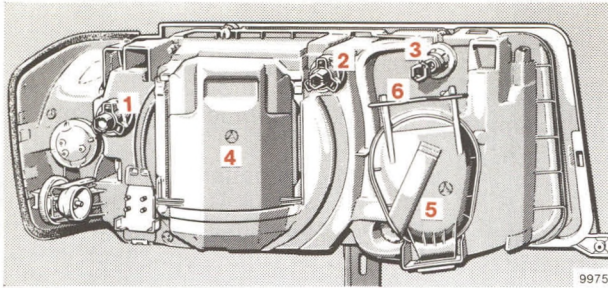

Headlamp Adjustment

Correct headlamp adjustment is extremely important. Check and readjust headlamps at regular intervals and when a lamp has been replaced.

Replacing Bulbs

Only handle new bulbs for headlamps and tail lamps with tissue paper or similar.

Install only 12 volt bulb with the specified watt rating.

Headlamp Assembly

- 1 Headlamp horizontal adjusting screw
- 2 Headlamp vertical adjusting screw
- 3 Fog lamp adjusting screw
- 4 Headlamp cover
- 5 Fog lamp cover

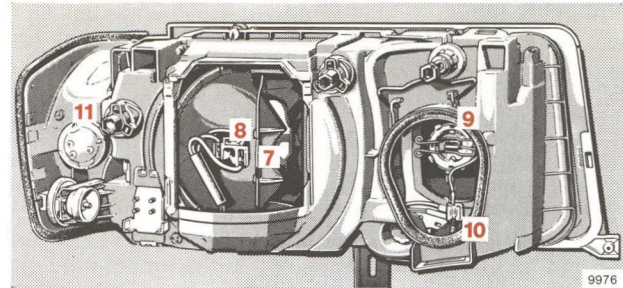

- 6 Fog lamp cover clamp
- 7 Headlamp cover clamp
- 8 Headlamp electrical connector
- 9 Fog lamp
- 10 Fog lamp electrical connector
- 11 Turn signal, parking, side marker and standing lamp bulb

Replacing bulbs:

Bulb for turn signal, parking, side marker and standing lamp (21/5 W/32/3 cp):

Turn bulb socket (11) with lamp bulb to the left and pull out socket. Push lamp bulb into socket and turn to the left and pull out bulb.

Sealed Beam/Halogen headlamp:

Pull cover (4) up to release it from bracket.

Disconnect plug (8) and disengage clamp (7).

Take out sealed beam together with retaining frame towards the front. Press off frame from sealed beam.

Fog lamp bulb (H 3):

Disengage clamp (6) and remove cover (5). Disconnect plug (10), disengage retaining clip and remove bulb (9).

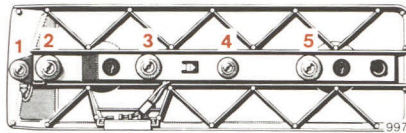
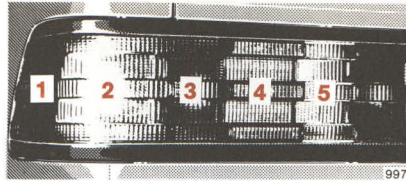

Tail Lamp Assemblies

- 1 Side marker lamp (10 W/6 cp)
- 2 Turn signal lamp (21 W/32 cp)
- 3 Stop lamp (21 W/32 cp)
- 4 Tail, parking and standing lamp (10 W/6 cp)
- 5 Backup lamp (21 W/32 cp)

Turn both locks in the trunk to the left as far as the stop and detach lamp bracket. To replace the bulbs, depress, turn to the left and remove.

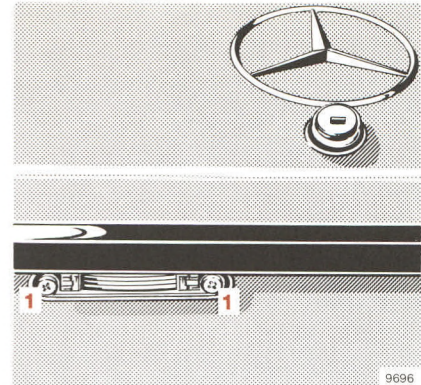

License Plate Lamps (5 W festoon lamp)

Loosen both the securing screws (1) and take out lamp.

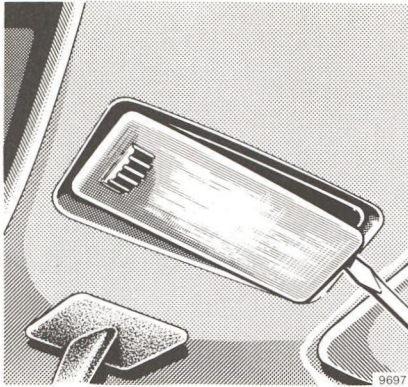

Interior Lamps
(10 W festoon lamp)

To replace the bulb, lift off front lamp at RH side, pull it out and open reflector.

The same applies to the removal of the rear lamp.

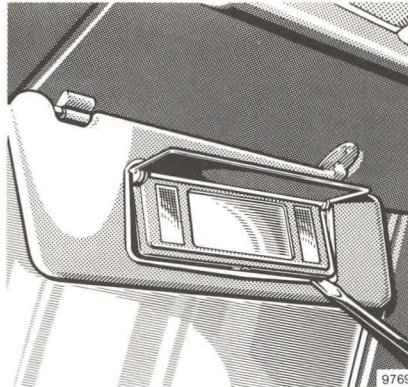

Sun Visor Lamps
(5 W festoon lamp)

To replace a bulb, pry off the cover by inserting a screwdriver in the left and right slots located on the lower edge.

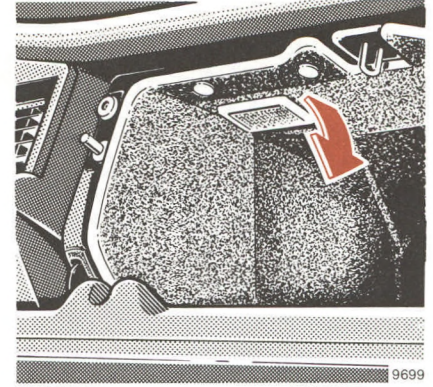

Glove Compartment Lamp
(5 W festoon lamp)

To replace the bulb, pull out lamp.

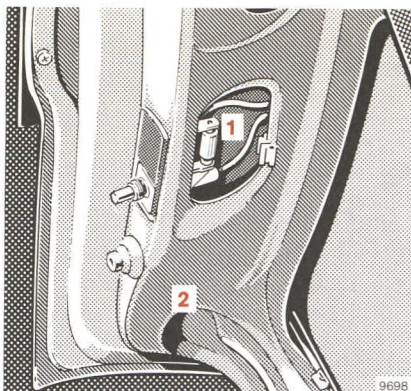

Trunk Lamp (10 W festoon lamp)

The bulb (1) is easily accessible when the trunk lid (2) is opened.

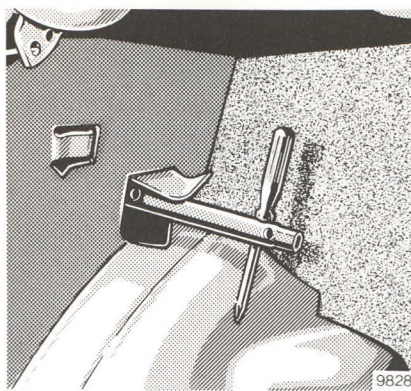

Emergency Operation of Sliding Roof

The sliding roof can be opened or closed manually should an electrical malfunction occur.

Remove small access plug in left side-panel of trunk. Insert socket wrench (from tool kit) through opening in panel and place on the hex-drive on the electric motor. Turn socket wrench as desired to open or close roof.

Turning socket clockwise closes roof.

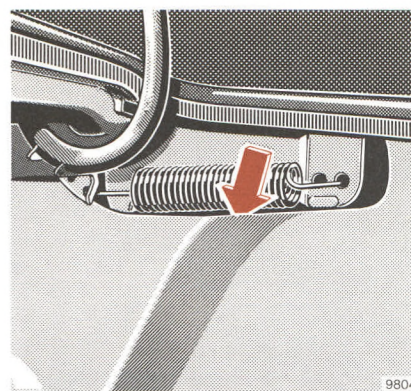

Unlocking of Fuel Filler Flap

If the central locking system does not release the fuel filler flap automatically, pull down right trunk panel slightly and pull back the connecting rod between the vacuum element and door tab while pushing in the door to open it.

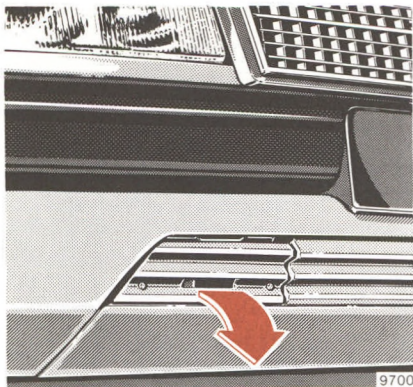

Tow-starting and Towing the Vehicle

The rear towing eye is welded from below to the right side of the spare tire compartment. The front towing eye is located behind the flap in the front bumper panel (arrow).

Flap removal: Insert finger in the opening of the flap, pull the flap out slightly and downward to remove.

To install the flap, engage the flap at the top and press in the bottom securely.

Engage hook of towing bar from the right side of the towing eye. This will ensure adequate clearance between the towing bar and the bumper panel opening during turns.

Only tow-start vehicle with the battery connected and the key in steering lock position 2.

Warning!

When the engine is not running, both the service brake and the steering are without power assistance. Under these circumstances, a much greater effort is necessary to steer or stop the vehicle.

Tow-starting a Vehicle with Automatic Transmission

Shift selector lever to position "N". Turn key in steering lock to position 2 and have vehicle towed.

After attaining a towing speed of 30 km/h/18 mph (with cold transmission) or 50 km/h/30 mph (with warm transmission), shift selector lever to position "2" to tow-start the engine. Touch the accelerator only when the engine starts firing. As soon as the engine has started, immediately return selector lever to "N".

It is important to allow the engine to idle for at least 1 minute before starting off because the preglowing process starts when the key is in steering lock position 2 and is not immediately disrupted after the engine has been tow-started. During this time the preglowing process is cut out automatically.

If the engine has not fired after a few seconds, shift the selector lever to "N" to protect the transmission from damage.

For a new starting attempt, tow-start the vehicle for some time again with the selector lever in position "N" and repeat the starting procedure.

The same method can be used to start the engine in emergencies when rolling downhill.

Towing a Vehicle with Automatic/Manual Transmission

The vehicle may be towed with all of the wheels on the ground and the selector lever in position “N”/neutral for distances up to 120 km/75 miles and at a speed not to exceed 50 km/h/30 mph.

To positively avoid a possibility of damage to the transmission, however, we recommend to disconnect the drive shaft at the rear axle drive flange on any towing beyond a short tow to a nearby garage.

Front towing: Attach J-hooks to lower control arms. Position a 4 ft long, 4 in × 4 in piece of wood with spacer blocks under tie-down hooks. Attach safety chains to tie-down hooks.

Rear towing: Attach T-hooks to tie-down slots in frame (behind spring seat). Attach safety chains to lower spring links.

Jump Starting

If the battery is discharged the engine can be started with jumper cables (minimum cable cross section is 25 mm²) and the (12 V) battery of another vehicle. Proceed as follows:

1. Turn key to steering lock position 0.
2. First connect jumper cables to the positive battery terminals and then to the negative terminals.
3. Start and run engine of jumper vehicle at high idle.
4. Start engine of the disabled vehicle in the usual manner.
5. After the engine has started, first remove jumper cables from the negative battery terminals and then from the positive terminals.

Instructions:

A discharged battery can freeze at approx. – 10° C/+14° F. In all cases it must be thawed out before jumper cables are used.

Warning!

Battery fluid contains sulfuric acid. Do not allow this fluid to come in contact with eyes, skin, or clothing. In case it does, immediately flush affected area with water, if necessary seek medical help.

A battery will also produce hydrogen gas, which is flammable and explosive. Keep flames or sparks away from battery, i. e. improper connection of jumper cables, cigarette smoking, etc..

Never lean over batteries while jump starting.

Cleaning and Care of the Vehicle

In operation, your vehicle is subjected to a great amount of varying external influences which, if gone unchecked, can attack the paint-work as well as the underbody and cause lasting damage.

Such damage is caused not only by extreme and varying climatic conditions, but also by air pollution, road salt, tar, gravel and stone chipping. Grease and oil, fuel, coolant, brake fluid, bird droppings, tree resins, etc. should immediately be removed to avoid paint damage. Frequent washing, however, reduces and/or eliminates the aggressiveness and potency of the above adverse influences.

More frequent washings are necessary to deal with unfavorable conditions; for example, near the ocean, in industrial areas (smoke, exhaust emissions), or during winter operation.

You should check your vehicle from time to time for stone chipping or other damage. Any damage should be repaired as soon as possible to prevent the start of corrosion.

In doing so, do not neglect the underside of the car. A prerequisite for a thorough check is a washing of the underbody followed by a thorough inspection. Damaged areas need to be re-undercoated.

Your vehicle has been treated at the factory with a wax-base rustproofing in the body cavities which will last for the lifetime of the vehicle. Post-production treatment is neither necessary nor recommended by MERCEDES-BENZ because of the possibility of incompatibility between materials used in the production process and others applied later.

After every engine cleaning you should have the engine compartment re-rustproofed. Before rustproofing, all control linkage bush-

ings have to be lubricated with hydraulic oil (check with your local MERCEDES-BENZ dealership for recommended brands).

We have selected car-care products and compiled recommendations which are specially matched to our vehicles and which always reflect the newest in technological standing. You can obtain MB car-care products at every MERCEDES-BENZ dealer.

Scratches, corrosive deposits, corrosion or damage due to negligent or incorrect care cannot always be removed with the car-care products recommended here. In such cases it is best to seek aid at your authorized MERCEDES-BENZ dealer.

The following topics deal with the cleaning and care of your vehicle and give important "how-to" information as well as references to recommended MB car-care products.

Car Washing

Before washing your vehicle, remove insect residues. The car should not be washed in the sun.

Use only a mild car wash detergent, such as MB auto shampoo.

Thoroughly spray the car with a diffused jet of water. Direct only a very weak spray towards the ventilation intake. Use plenty of water and rinse the sponge and chamois frequently. Rinse with clear water and thoroughly wipe dry with a chamois.

If the vehicle has been run through an automatic car wash – in particular one of the older installations – rewipe the recessed sections provided in the tail lamps (for improved prevention of soiling) if necessary. No solvents (fuels, thinners etc.) must be used.

In the winter, thoroughly remove all traces of road salt as soon as possible.

When washing the underbody, do not forget to clean the inner sides of the wheels.

Tar Stains

Quickly remove tar stains before they dry and become more difficult to remove.

Window Cleaning, Wiper Blades

Use a window cleaning solution on very dirty or oil-stained windows. Clean windshield wiper blades with a clean cloth and detergent solution. Replace blades at least once or twice a year.

To assist with the removal of accumulated road film on the windshield and improve wiping ability, a cap of MB auto shampoo can be added to the 3 liter container of washer solvent.

Plastic Parts, Headliner, Rubber Parts and MB-Tex Upholstery Covers

Do not use oil or wax on these parts.

Using aftermarket seat covers or wearing clothing that have the tendency to give off coloring (e.g.

when wet, etc.) may cause the upholstery (velour for example) to become permanently discolored. By lining the seats with a proper intermediate cover, contact-discoloration will be prevented.

Seat Belts

The webbing must not be treated with chemical cleaning agents. Use only clear, lukewarm water and soap. Do not dry the webbing at temperatures above 80° C/176° F or in direct sunlight. Never bleach or re-dye the webbing.

Steering Wheel, Gear Shift Lever and Instrument Cluster

Use a gentle dish-washing detergent or mild detergent for delicate fabrics as a washing solution. Wipe with a cloth moistened in lukewarm solution. Do not use scouring agents.



Upholstery

Leather: Wipe leather upholstery with a damp cloth and dry thoroughly. Exercise particular care when cleaning perforated leather as its underside should not become wet.

Velours: Pressure marks resulting from dampness and heat may appear to be stains. Such marks can be removed by wiping with a moistened brush, ironing with a wet cloth or by treating with a dry shampoo. Do not sit on damp upholstery. Quick drying is achieved by applying hot air – for example, by using a hair dryer. If in doubt, please consult your authorized MERCEDES-BENZ dealer.

Paintwork

Do not apply wax if your car is parked in the sun or if the hood is still hot.

For maximum protection, the paintwork should be waxed approximately once every three months. Use the appropriate MERCEDES-BENZ Touch-Up Stick for quick and provisional repairs of minor paint damage.

Light Alloy Wheels

If possible, clean wheels once a week with lukewarm water and autoshampoo. Use an ample supply of water.

To remove stubborn marks, use polish or paint cleaner and apply with buffing cloth or a soft cloth.

Ornamental Moldings

For regular cleaning and care of very dirty chrome-plated parts, use a chrome cleaner.

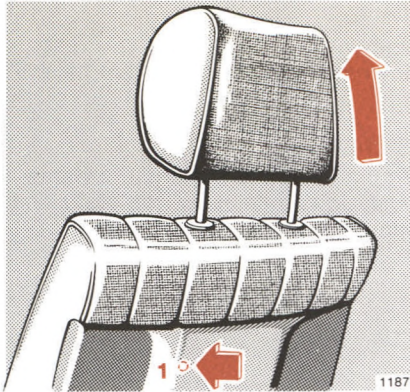

Safety Head Restraints

Removing head restraints of front seats:

Move the manually adjustable head restraint slightly forward and pull up to the stop.

Bring the electrically adjustable head restraint to its highest position.

Depress release button (1) to be felt under the seatback covering material and pull head restraint up sharply, holding it by the left head restraint post (viewed in driving direction). Then pull out head restraint completely with both hands.

The release button (1) is located below the left head restraint post on both front seats.

Removing rear seat head restraints:

Pull head restraint up until detent is felt. Then pull it out sharply using both hands.

Installing head restraints:

Insert the head restraint and push it down.

With power head restraint it may be necessary to first push up adjustment switch for 5 seconds.

Head restraint may now be adjusted as desired.

Note:

For your protection, drive only with properly positioned head restraints.

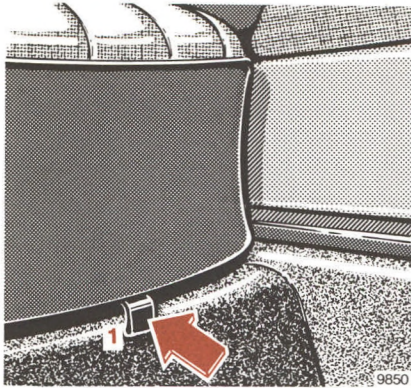

Rear Seat Cushion

Removal: Push in locking tabs (1) (on left and right side) and carefully pull up seat at the front (do this carefully to avoid injury!).

Installation: Slide rear edge of cushion under the backrest so that both wire loops under the backrest engage at the seat cushion. Push front of cushion down until it locks in place.

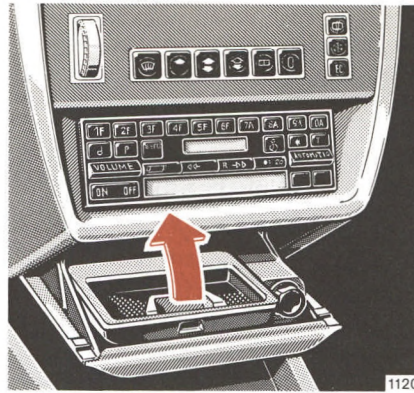

Ash tray

Removal, front:

Open ash tray against stop. Place hand under tray. Pull frame up and out.

Removal, rear:

Open ash tray against stop. Press down center spring and remove ash tray.

Installation:

Engage ash tray bottom into frame, push down release spring and close ash tray.



Roof Rack

Use only our approved roof rack to avoid damage to the vehicle.

Mount supports only between markings on border of roof which are visible when doors are opened.

Spare Parts Service

All MERCEDES-BENZ dealers maintain a stock of original spare parts required for maintenance and repair work. In addition, strategically located parts distribution centers provide quick and reliable parts service.

More than 200 000 different spare parts, even for older models, are available.

MERCEDES-BENZ original spare parts are subjected to most severe quality inspections. Each part has been specifically developed, manufactured or selected for and adapted to MERCEDES-BENZ vehicles. Therefore, MERCEDES-BENZ original spare parts should be installed.

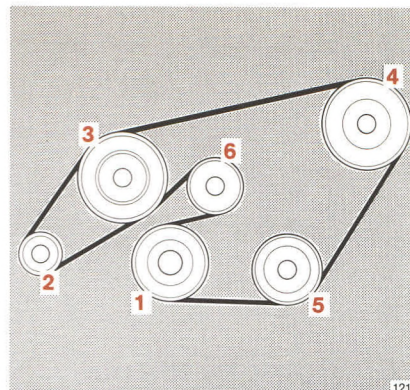

Layout of Poly V-belt Drive

- 1 Crankshaft
- 2 Alternator
- 3 Coolant pump – fan
- 4 Power steering pump
- 5 Air conditioning compressor
- 6 Tensioning pulley with tensioning device

For dimensions of the poly V-belt, see page 88.

Technical Data Fuels, Coolants, Lubricants etc.

Identification Plates	86
Vehicle Data Cards	87
Warranty Coverage	87
Technical Data	88
Fuels, Coolants, Lubricants, etc.	90
Capacities	90
Engine Oils	93
Brake Fluid	93
Diesel Fuels	94
Coolants	95
Consumer Information	96

Identification Plates

When ordering spare parts, please quote chassis and engine numbers.

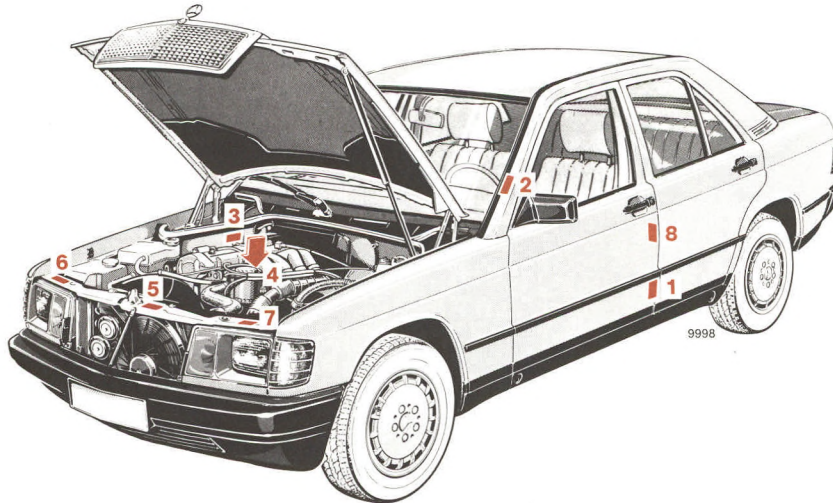

- 1 Certification Tag
(left door pillar)
- 2 Identification Tag
(left window post)
- 3 Chassis No.
- 4 Engine No.
- 5 Body No. and Paintwork No.
- 6 Information Tag
California version
Vacuum line routing
for emission control system
- 7 Emission Control Tag
- 8 Emission Control Tag
Catalyst Information

Vehicle Data Cards

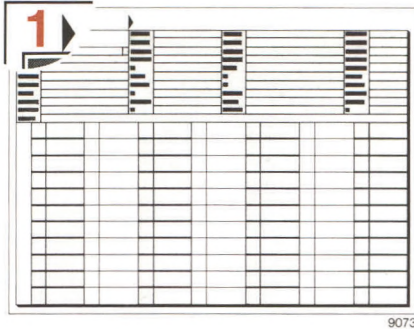

The vehicle data cards bear all the important data relating to your vehicle.

Data card No. 1 bears the key number and should never be left in the vehicle. Submit this card to your authorized MERCEDES-BENZ dealer to request a replacement key in case of loss.

Data card No. 2 bears no key data and is kept in the Maintenance Booklet. Presenting this card to the dealer will facilitate the processing of the order.

Warranty Coverage

Your car is covered under the terms of the “warranties” printed in the Owner’s Service and Warranty Policy Booklet, and your dealer will exchange or repair any defective parts in accordance with the terms of the following warranties:

1. New vehicle limited warranty
2. Emission systems warranty
3. Emission performance warranty
4. California emission control systems warranty (state of California only, unless purchased optionally for diesel models).

Loss of Owner’s Service and Warranty Policy

Should you lose your Owner’s Service and Warranty Policy Booklet, have your local MB dealer arrange for a replacement. It will be mailed to you.

Technical Data

Type	190 D 2.2 (201. 122) ¹
------	-----------------------------------

Engine

Engine type	601
Work cycle	Diesel four stroke
No. of cylinders	4
Bore	87.0 mm/3.43 in
Stroke	92.4 mm/3.64 in
Total piston displacement	2197 cm ³ /134.1 in ³
Compression ratio	22
Output acc. to SAE	54 kW/4200 rpm/ 72 net-bhp/4200 rpm
Injection order	1-3-4-2
Poly V-belt (single drive belt)	2120 mm

¹ The quoted data apply only to the standard vehicle. See an authorized MERCEDES-BENZ dealer for the corresponding data of all special bodies and special equipment.

Transmission

Design	Manual five-speed transmission
Optional extra	Automatic four-speed torque-converter transmission

Steering System

Design	Power steering
--------	----------------

Rims-Tires

Rims (forged light alloy rims)	5 J × 14 H 2
Summer tires: Radial-ply tires	175/70 R 14 82 S 175/70 R 14 84 S
Winter tires: Radial-ply tires	175/70 R 14 82 Q M + S 175/70 R 14 84 Q M + S

Technical Data

Electrical System

Alternator	14 V/70 A
Starter motor	12 V/2.2 kW
Battery	12 V/72 Ah

Weights	See certification tag
----------------	-----------------------

Main Dimensions

Overall vehicle length	4445 mm/175.0 in
Overall vehicle width	1678 mm/ 66.1 in
Overall height	1383 mm/ 54.4 in
Wheel base	2665 mm/104.9 in
Track, front	1430 mm/ 56.3 in
Track, rear	1415 mm/ 55.7 in

	Capacity	Fuels, coolants, lubricants, etc.
Manual transmission	1.5 l/1.6 US qt	Automatic transmission fluid for manual transmission ¹
Automatic transmission	Initial fill: 6.6 l/7.0 US qt Fluid change: 5.5 l/5.8 US qt	Automatic transmission fluid for automatic transmission ¹
Rear axle	0.7l/0.7 US qt	Hypoid gear oil SAE 90, 85 W 90 ¹
Power steering	0.6 l/0.6 US qt	Automatic transmission fluid for power steering ¹
Accelerator control linkage		Hydraulic fluid ¹
Front wheel hubs	50 g each, approx. 1.8 oz. each approx.	High temperature roller bearing grease

¹ For recommendations on recommended brands, see your nearest MERCEDES-BENZ dealer.

	Capacity	Fuels, coolants, lubricants, etc.
Battery terminals		Bosch special grease
Brake and (with manual transmission) clutch reservoir	approx. 0.5 l/0.5 US qt	Brake fluid ¹
Windshield washer system	approx. 3.0 l/3.2 US qt	Windshield washer solvent
Fuel tank including a reserve of	approx. 55 l/14.5 US gal approx. 7.0 l/1.8 US gal	Diesel fuels acc. to ASTM D 975 grades 1 and 2 as well as VV-F-800 a grades 1 and 2
Cooling system	approx. 8.5 l/9.0 US qt	Coolant ¹

¹ For recommendations on recommended brands, see your nearest MERCEDES-BENZ dealer.

Engine Oils

Engine oils are specifically tested for their suitability in our engines. Therefore, use only engine oils recommended by us. Information on recommended brands is available at any authorized MERCEDES-BENZ dealer.

On a new vehicle, the engine is filled with break-in oil in the factory. This oil is specially developed for the specific operating conditions during the first 1300–1600 km/800–1000 miles.

If engine oil has to be added before the first inspection 1300–1600 km/800–1000 miles, you may use one of the recommended oils listed on the flyer included with your vehicle literature: “Factory Approved Engine Oils, Coolant-Antifreeze and Brake Fluid”.

Brake Fluid

During the course of the operation of the vehicle, the boiling point of the brake fluid is continuously reduced through the absorption of moisture from the atmosphere. Under extremely hard operating conditions, this moisture content can lead to the formation of vapor in the system, thus reducing the system’s efficiency. The brake fluid must therefore be replaced annually, preferably in the spring. It is recommended to use only brake fluid approved by MERCEDES-BENZ.

Your MERCEDES-BENZ dealer will provide you with additional information.



Diesel Fuels

Use only commercially available vehicular diesel fuels No. 2 or No. 1 (ASTM D 975 No. 2-D or No. 1-D).

Change engine oil in compliance with section "Engine Oil Change and Oil Filter Service" if diesel fuels are used whose sulphur content exceeds 0.5% by weight. Marine diesel fuel, heating oil or the like must not be used.

At very low temperatures the fluidity of No. 2-D diesel fuel may become insufficient due to paraffin separation.

To avoid malfunctions, No. 2-D diesel fuel of a lowered cloud point is marketed during the cold season.

At temperatures below 0° C/ + 32° F use winterized or No. 1 diesel fuel only. If not available, a certain quantity of kerosene may be added. Mixing only to be done within the cars' fuel tank. Kerosene has to be filled in before the diesel fuel.

Engine power may drop according to the proportion of kerosene. For this reason, keep percentage of kerosene added to the minimum necessitated by the ambient temperature.

The following table can be used as a reference, if adding of kerosene becomes necessary. The mixing ratios shown refer to the total mixture.

Even in extreme climatic conditions, the maximum mixture ratio should not exceed 50%.

Adding of kerosene to No. 1-D diesel fuel is not recommended even at low temperatures.

Warning!

Always follow basic safety rules when working with any combustible material. Do not fill the fuel tank or mix diesel fuel and kerosene when smoking, near an open flame or while the vehicle's engine is running. An explosion or fire can result.

Ambient temperature	No. 2 Diesel Fuel %	Kerosene %
0° C to -10° C/ +32° F to +14° F	70	30
below -10° C/ +14° F	50	50

Coolants

The engine coolant is a mixture of water and anticorrosion/antifreeze, which provides:

- corrosion protection
- freeze protection
- boiling protection (by increasing the boiling point).

The cooling system was filled at the factory with a coolant providing freeze protection to $-30^{\circ}\text{C}/-22^{\circ}\text{F}$ and corrosion protection. The red area of the temperature gauge is matched to the heating properties of this coolant solution.

The coolant solution must be used year round to provide the necessary corrosion protection and increase in the boil-over protection. You should have it replaced every 3 years.

To provide the important corrosion protection, the solution must be at least 33% anticorrosion/antifreeze (equals a freeze protection to $-20^{\circ}\text{C}/-4^{\circ}\text{F}$). If you use a solution that is more than 55% anticorrosion/antifreeze (freeze protection to $-40^{\circ}\text{C}/-40^{\circ}\text{F}$), the engine temper-

ature will increase due to the lower heat transfer capability of the solution. Therefore, do not use more than this amount of anticorrosion/antifreeze.

If the coolant level is low, water and M-B anticorrosion/antifreeze should be used to bring it up to the proper level (have cooling system checked for signs of leakage).

The water in the cooling system must meet minimum requirements, which are usually satisfied by normal drinking water. If you are not sure about the water quality, consult your authorized MERCEDES-BENZ dealer.

Anticorrosion/antifreeze

Your vehicle contains a number of aluminium parts. The use of aluminium components in motor vehicle engines necessitates that anticorrosion/antifreeze/coolant used in such engines be specifically formulated to protect the aluminium parts. (Failure to use such anticorrosion/antifreeze/coolant may result in a significantly shortened service life.)

While there may be a number of anticorrosion/antifreeze/coolants available which will provide the requisite protection, all such products have not been tested for MERCEDES-BENZ vehicles. The following product, however, is recommended for use in your car: MERCEDES-BENZ Anticorrosion/Antifreeze Agent.

Before the start of the winter season (or once a year in the hot southern regions), you should have the anticorrosion/antifreeze concentration checked. The coolant is also regularly checked each time you bring your vehicle to your authorized MERCEDES-BENZ dealer for maintenance service.

Freeze protection	Anticorrosion/antifreeze
-30°C } -22°F }	3.75 l/4.0 US qt
-40°C } -40°F }	4.50 l/4.8 US qt

Consumer Information

This has been prepared as required of all manufacturers of passenger cars under Title 49, Code of U. S. Federal Regulations, Part 575 pursuant to the "National Traffic and Motor Vehicle Safety Act of 1966".

Uniform Tire Quality Grading

Relevant tire grade information on tire flanks.

All passenger car tires must conform to federal safety requirements in addition to these grades.

Traction "A", "B", "C"

The traction grades, from highest to lowest, are "A", "B" and "C" and they represent the tire's ability to stop on wet pavement as measured under controlled conditions on specified government test surfaces of asphalt and concrete. A tire marked "C" may have poor traction performance.

Warning: The traction grade assigned to this tire is based on braking (straightahead) traction tests and does not include cornering (turning) traction.

Temperature "A", "B", "C"

The temperature grades of "A" (the highest), "B" and "C" representing the tire's resistance to the generation of heat and its ability to dissipate heat when tested under controlled conditions on a specified indoor laboratory test wheel. Sustained high temperature can cause the material of the tire to degenerate and reduce tire life, and excessive temperature can lead to sudden tire failure. The grade "C" corresponds to a level of performance which all passenger car tires must meet under the Federal Motor Vehicle Safety Standard No. 109. Grades "B" and "A" represent higher levels of performance on the laboratory test wheel than the minimum required by law. Warning: The temperature grade for this tire is established for a tire that is properly inflated and not overloaded. Excessive speed, underinflation, or excessive loading, either separately or in combination, can cause heat build-up and possible tire failure.

Vehicle Stopping Distance

This figure indicates braking performance that can be met or exceeded by the vehicles to which it applies, under different conditions of loading and with partial failures of the braking system. The information presented represents results obtainable by skilled drivers under controlled road and vehicle conditions, and the information may not be correct under other conditions.

Description of the vehicles to which this table applies: **190 D 2.2**

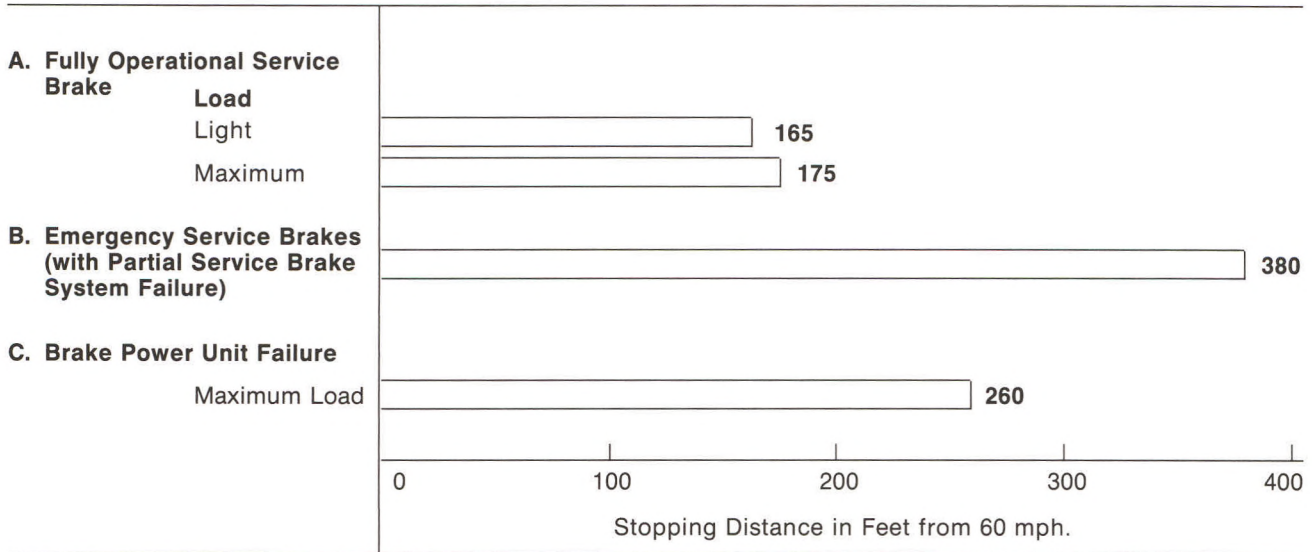



ABS Brake system
(Anti-lock brake system) 56
Adding coolant 63
Adjusting power seats, front 29
Anticorrosion/antifreeze 95
Anti-theft alarm system 27
Arm rest 31
Ash tray 82
Automatic antenna 50

Battery 71
Bleeding of fuel system 66
Body No. 86
Brake fluid 57, 93
Brake pad wear indicator
lamp 57

Capacities 90
Central locking system 26
Certification tag 86
Changing wheels 69
Charge indicator lamp 57
Chassis No. 86
Checking coolant level 63
Cleaning and care of the vehicle 78
Combination switch 39

Consumer information 96
Coolants 95
Coolant temperature
gauge 58
Cruise control 55

Diesel fuels 94
Driver airbag 33

Emergency operation
of sliding roof 75
Emergency tensioning
retractors 33
Emission control 59
Emission control tag 86
Engine No. 86
Engine oils 93
Engine oil and filter
change 15
Engine oil consumption 58
Engine oil level check 64
Exterior mirrors 40

First aid kit 67
Flat key 24
Fluid level – automatic
transmission 65

Fuels, coolants,
lubricants, etc. 90
Fuel reserve warning lamp 58
Fuses 71

Headlamp adjustment 72
Heated seats 32
High altitude correction device 59
Hints for driving 13
Hood 62

Identification plates 86
Information tag,
California version 86
Inside rear view mirror 40
Instruments and controls 8
Instrument cluster 10
Interior lamps 41

Jack 67
Jump starting 77

Layout of poly V-belt drive 83
Lighter 43
Lighting switch 38
Locking and unlocking of doors 25

Low engine coolant level
indicator lamp 58
Low engine oil level
indicator lamp 57
Low windshield washer level
indicator lamp 58

Maintenance system 15
Manual seat adjustment, front 28
Master key 24

Obtaining replacement keys 24
Oil pressure gauge 57
Opening the doors 25
Orthopedic seat backrest 30
Outside temperature indicator 58

Paintwork No. 86
Parking brake 52
Power windows 44

Radio 45
Rear seat cushion 82
Rear window defroster 42
Replacing bulbs 72
Roof rack 83

Safety head restraints 81
Safety head restraints, rear 30
Seat belts 33
Service literature 102
Shelf below rear window 44
Sliding roof 43
Spare parts service 83
Spare wheel 67
Starting and shifting gears 52
Starting and turning off
the engine 12
Steering lock 37
Sun visors 41
Supplemental restraint system 33
Supplementary key 24

Technical data 88
Tempmatic climate control
system 18
The first 1500 km/1000 miles 6
Tires 68
Tire chains 60
Tire inflation pressure 70
Tow-starting and towing
the vehicle 76
Traveling abroad 59
Turning off engine manually 66

Unlocking of fuel filler flap 75

Vehicle data cards 87
Vehicle tool kit 67

Warranty coverage 87
Wheels 68
Winter driving 60

Service Literature

Customers who are interested in ordering service literature for their vehicles are advised to contact our subsidiaries in the U.S. or Canada at the following addresses, respectively

for U.S.A: Mercedes-Benz of N.A. Inc.
One Mercedes Drive
P.O. Box 350
Montvale, New Jersey 07645
Att: Technical Publications
Tel.: (201) 573-0600

for Canada: Mercedes-Benz of Canada
849 Eglinton Ave., East
Toronto 17, Ont., Canada
Att: Service Department
Tel.: 416-425-3550

The above companies will be happy to handle any such requests from customers.

We consider this to be the best way of obtaining accurate information for your vehicle.

Check Regularly and Before a Long Trip

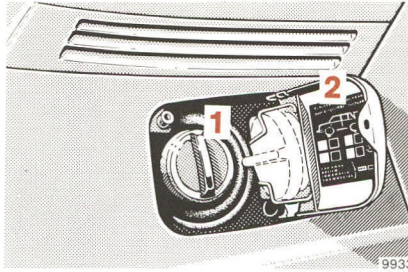
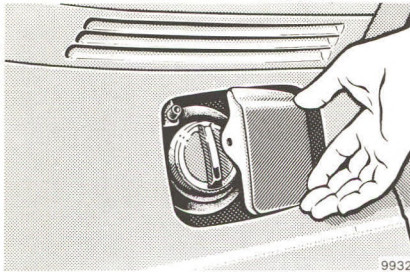

1 Fuel Supply: Turn fuel filler cap to the left and hold on to it until possible pressure in tank has been released.

2 Tire Pressure: Check at least every two weeks. For details see page 70.

3 Battery: Add distilled water only, see page 71.

4 Fluid Level in Automatic Transmission

5 Coolant level: See page 63.

6 Windshield Washer System: See page 92.

7 Engine Oil Level: See page 64.

8 Brake Fluid: See pages 57, 92 and 93.

Vehicle Lighting: Check function and cleanliness. For replacement of light bulbs, see pages 72 and 73.

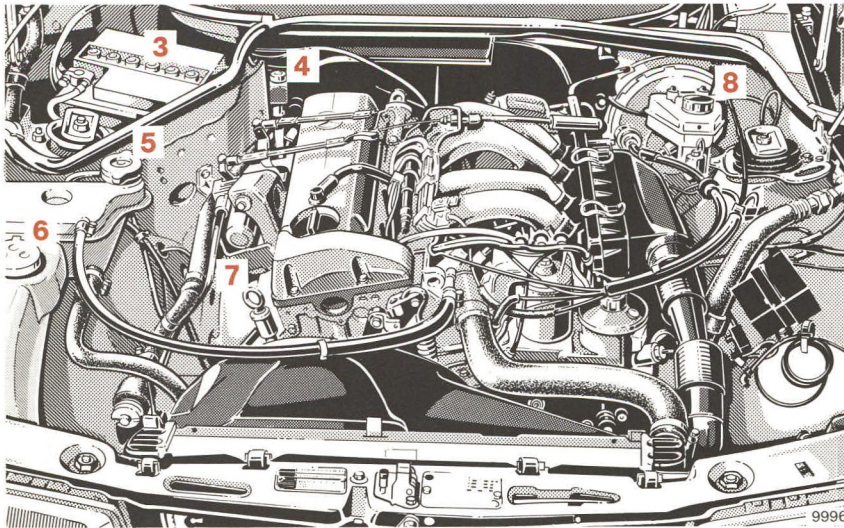

What You Should Know at the Gas Station

- **Fuel:** Diesel fuels acc. to ASTM D 975, grades 1 and 2 as well as VV-F-800 a grades 1 and 2. Fuel tank capacity approx. 55 l/14.5 US gal. This includes approx. 7.0 l/1.8 US gal reserve. Only fill fuel until the discharge nozzle unit cuts out – do not overfill.
- **Engine Oil:** Engine oil level check, see page 64. Quantity differential between upper and lower dipstick marking level: 2.0 l/2.1 US qt. Year-round multigrade oils 10 W-40, 10 W-50. For further information, refer to page 90.
- **Automatic Transmission:** Automatic transmission fluid for automatic transmission. For level checks and replenishment, refer to page 65.
- **Coolant:** For normal replenishment, use water (potable water quality). For further information (e.g. anticorrosion/anti-freeze), refer to page 95.
- **Bulbs:** High and low beams: Sealed beam/ Halogen, tail, parking and standing lamps 10 W/ 6 cp, turn signal, standing, side marker and parking lamps, front 21/5 W/32/3 cp, turn signal lamps, rear 21 W/32 cp, stop lamps 21 W/32 cp, license plate lamps 5 W festoon lamp.

- **Tire Pressure:** Cold tires:

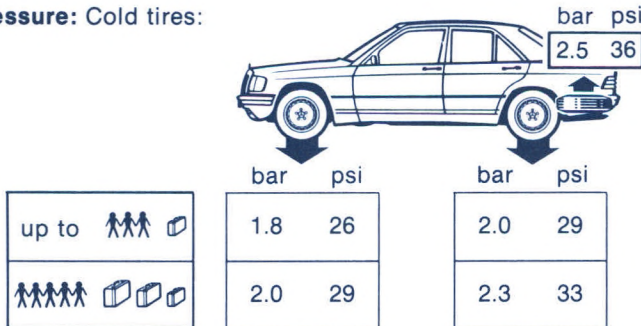

Warm tires:

Pressure may rise by up to +0.3 bar/+ 4 psi.

Never release any air from a warm tire to off-set this pressure increase.

Daimler-Benz AG
Stuttgart-Untertuerkheim
Zentralkundendienst



Mercedes-Benz
service

