

Mercedes-Benz



Owner's Manual

190 D 2.2

1984

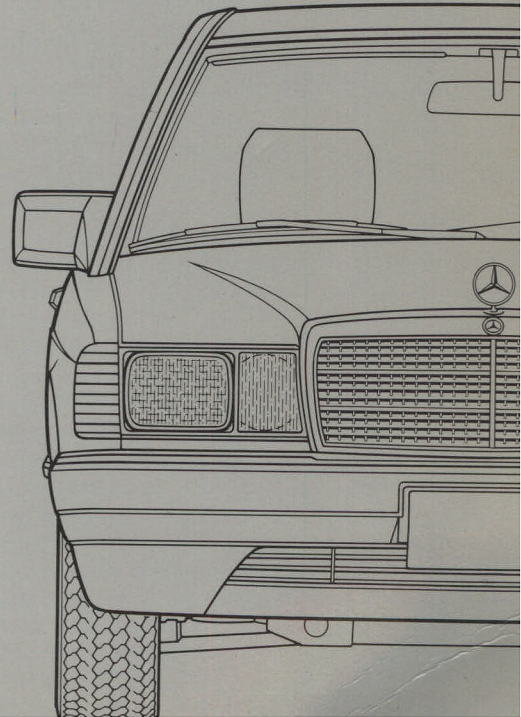

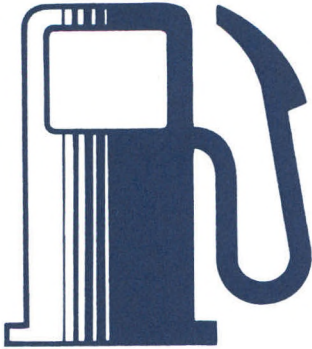

5
20

Drive Sensibly – Save Fuel

Fuel consumption depends to a great extent on driving habits and operating conditions.

In order to save fuel you should:

- ensure that tire pressures are correct
- not carry unnecessary loads
- remove ski racks or roof-mounted luggage racks when not in use
- not warm up your engine at idle and with the vehicle at standstill
- avoid frequent acceleration and deceleration
- avoid frequent braking
- shift gears on time, do not exceed $\frac{2}{3}$ of the individual gears' max. speed
- avoid unnecessarily high speeds
- have all the maintenance jobs specified by us carried out at regular intervals by a MERCEDES-BENZ service station.

Driving in low temperature weather, in stop-and-go city traffic and on short hops, and in hilly country as well, increases fuel consumption.

Owner's Manual

Mercedes-Benz



190 D 2.2

1984

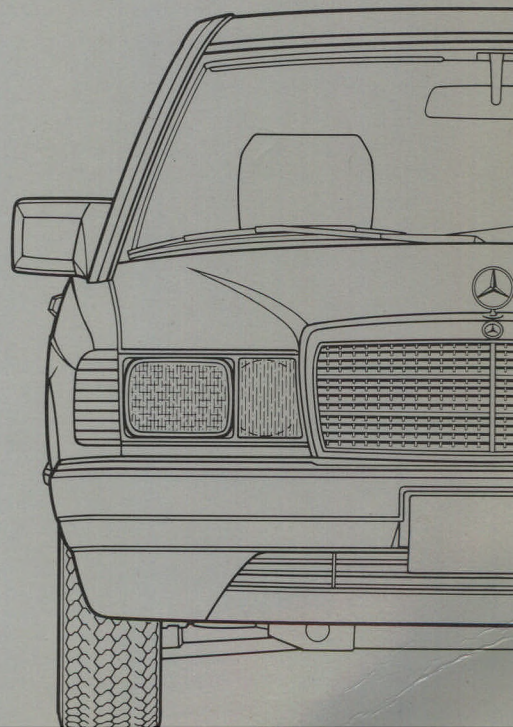

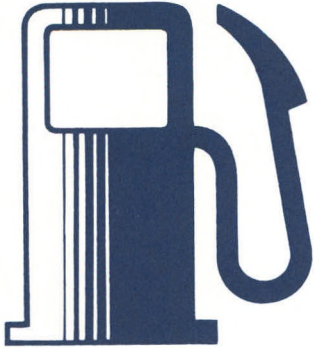

20

Drive Sensibly – Save Fuel

Fuel consumption depends to a great extent on driving habits and operating conditions.

In order to save fuel you should:

- ensure that tire pressures are correct
- not carry unnecessary loads
- remove ski racks or roof-mounted luggage racks when not in use
- not warm up your engine at idle and with the vehicle at standstill
- avoid frequent acceleration and deceleration
- avoid frequent braking
- shift gears on time, do not exceed $\frac{2}{3}$ of the individual gears' max. speed
- avoid unnecessarily high speeds
- have all the maintenance jobs specified by us carried out at regular intervals by a MERCEDES-BENZ service station.

Driving in low temperature weather, in stop-and-go city traffic and on short hops, and in hilly country as well, increases fuel consumption.

Mercedes-Benz



Owner's Manual

190 D 2.2

Chassis 201 D

1984

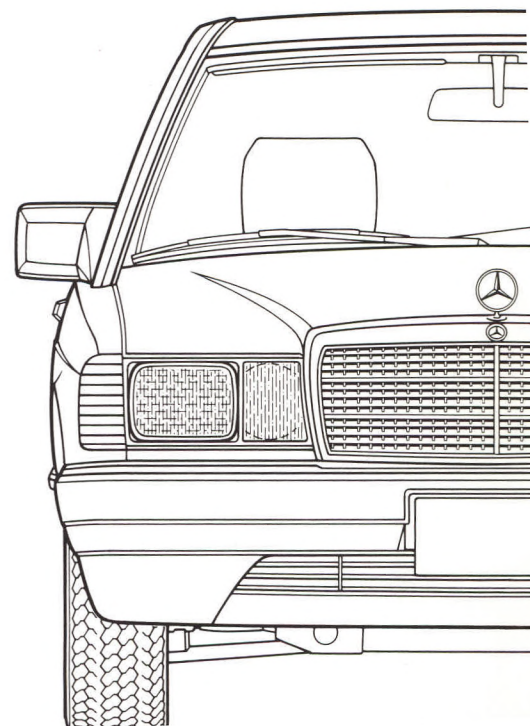

Printed in Germany

We reserve the right to modify the technical details of the vehicle as given in the data and illustrations of this Owner's Manual (s.e.e.o.). Reprinting, translation and copying, even of excerpts, is not permitted without our prior authorization in writing.

ZKD/8.83.8/MD

Our company and staff wishes you many hours of enjoyment with your new vehicle.

You have placed a lot of trust in our company name by purchasing a MERCEDES, from which you may expect that it will give you long service, with a minimum of trouble and that it is easy to operate.

We have just one request to make, hoping that it will benefit you as well:

Please do not put this manual aside without first carefully reading it.

This manual contains many important recommendations that could help you gain better control over your MERCEDES and more pleasure while driving it.

We wish you many miles of motoring pleasure.
Daimler-Benz Aktiengesellschaft

Special equipment is also described in this manual, including operating instructions wherever necessary. Since these are special-order items, the descriptions and illustrations herein may vary slightly from the actual equipment of your vehicle.

If there are any equipment details that are not shown or described in this Owner's Manual, your MERCEDES-BENZ dealer will be glad to inform you of correct care and operating procedures.

**Instruments and Controls, Starting the Engine
Driving Hints, Service and Maintenance**

Operation

Driving

Practical Hints

**Technical Data
Fuels, Coolants, Lubricants, etc.**

Index

Check Regularly and Before a Long Trip

See page 96

What You Should Know at the Gas Station

See last page

The First 1500 km/1000 Miles

The more cautiously you treat your engine during the break-in period, the more satisfied you will be with its performance later on. Therefore, drive your vehicle during the first 1500 km/1000 miles at moderate vehicle and engine speeds.

During this period, avoid heavy loads (full throttle driving) and high RPMs (no more than $\frac{2}{3}$ of maximum permissible speed in each gear).

Down shift at proper engine speed!

On vehicles with automatic transmission avoid accelerating by kick-down. It is not recommended to brake the vehicle by means of manually shifting to a lower gear. We recommend to select positions "3" or "2" only at moderate speeds (for hill driving).

After 1500 km/1000 miles, speeds may gradually be increased to the permissible maximum.

Instruments and Controls, Starting the Engine Driving Hints, Service and Maintenance

Instruments and Controls	8
Instrument Cluster	10
Starting and Turning off the Engine	12
Hints for Driving	13
MERCEDES-BENZ Maintenance System	15



Instruments and Controls

For more detailed descriptions see specified pages.

- 1 Air volume lever for side ventilation (page 18)
- 2 Adjustable side ventilation outlets (page 18)
- 3 Lighting switch (page 34)
- 4 Combination switch (page 35)
- 5 Cruise control (page 51)
- 6 Switch for rear courtesy lamp (page 38)
- 7 Instrument cluster (page 10)
- 8 Horn control
- 9 Steering lock with preglow/starter switch (page 33)
- 10 Switch for rear window defroster (page 38)
- 11 Switch for electric sliding roof (page 39)
- 12 Switch for automatic antenna (page 46)
- 13 Adjustable center ventilation outlets (page 18)
- 14 Air volume lever for side ventilation (page 18)
- 15 Glove compartment, illuminated (only in steering lock positions 1 or 2)
- 16 Air recirculation switch (page 18)
- 17 Fan speed control lever (page 18)
- 18 Tempmatic climate control system (page 18)
- 19 Radio (page 41)
- 20 Ash tray with lighter (page 39, 75)
- 21 Switch group for power windows (page 40)
- 22 Switch for hazard warning flasher system
- 23 Adjusting lever for exterior mirror on front passenger side (page 36)
- 24 Loudspeaker – fader control
- 25 Switch for left front seat heater (page 30)
- 26 Switch for right front seat heater (page 30)

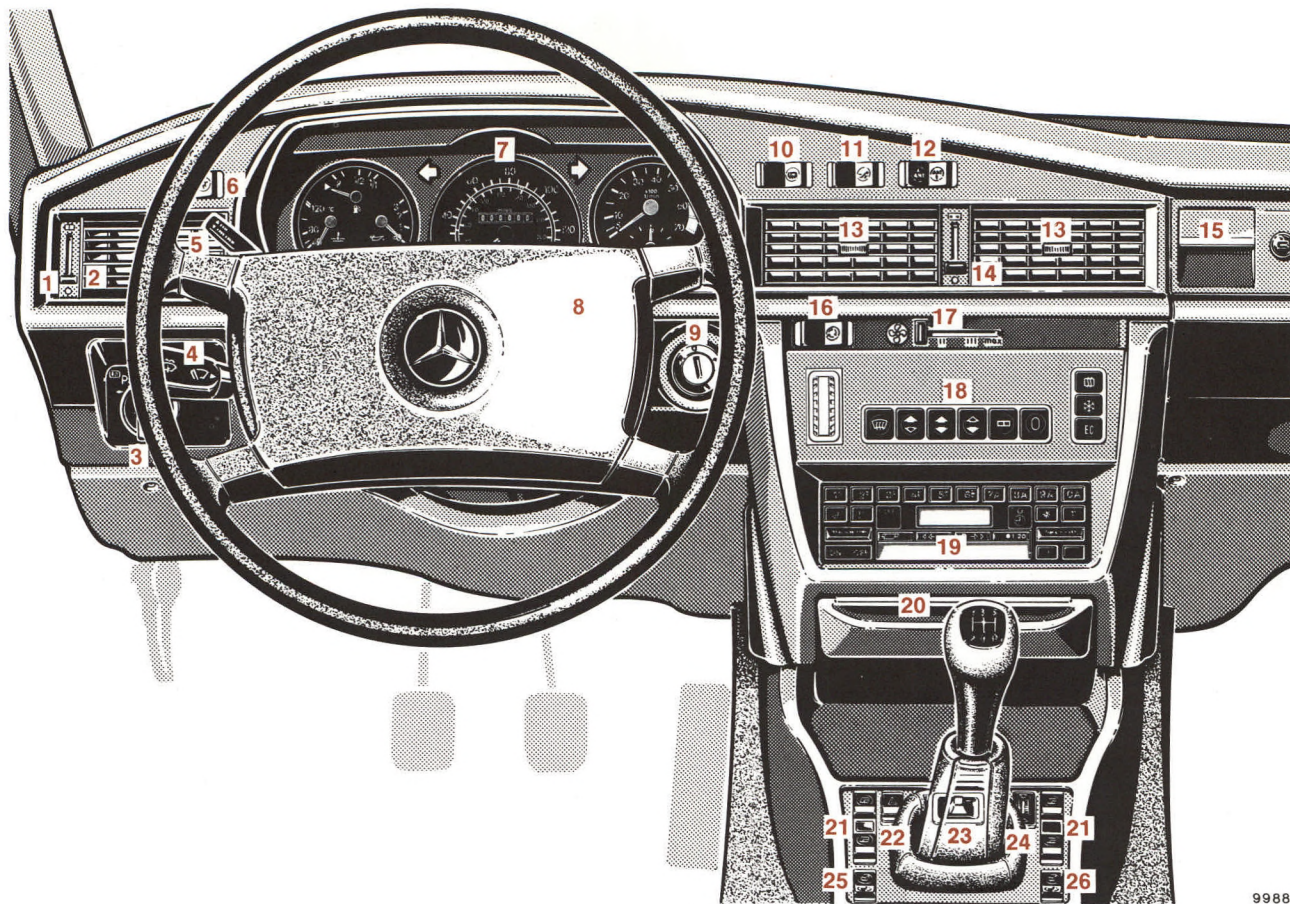

9988



Instrument Cluster

- 1** Coolant temperature gauge ($^{\circ}$ C)
Up to red marking: Maximum permissible temperature for an anti-corrosion/antifreeze-blended fill protecting down to -30° C/ -22° F. See page 52
- 2** Fuel gauge with reserve warning lamp (yellow):
Comes on when the steering lock key is moved to driving position 2 and must go out when the engine is idling. See page 52
Fuel reserve and capacity, refer to page 84 and last page.
- 3** Oil pressure gauge (bar). See page 52
- 4** Turn signal indicator lamp, left (green)
- 5** Speedometer
- 6** Main odometer
- 7** Trip odometer
- 8** Turn signal indicator lamp, right (green)
- 9** Tachometer
- 10** Electric clock
- 11** Seat belt warning lamp (red)
- 12** Knob for clock adjustment
(press in for adjustments)
- 13** Outside temperature gauge
- 14** Knob for instrument lamps and trip odometer
Rotate knob: instrument lamps intensity are infinitely variable
Depress knob: trip odometer is turned back
- 15** Preglowing indicator lamp (yellow)
- 16** Charge indicator lamp (red):
Comes on when the steering lock key is moved to driving position 2 and must go out when the engine is idling. See page 52
- 17** Brake warning lamp (red) comes on if
 - the parking brake is engaged
 - not enough brake fluid is in the reservoir
- 18** Brake pad wear indicator lamp (yellow):
Lights up during braking if the front wheel brake pads are worn down. See page 52
- 19** High beam indicator lamp (blue)

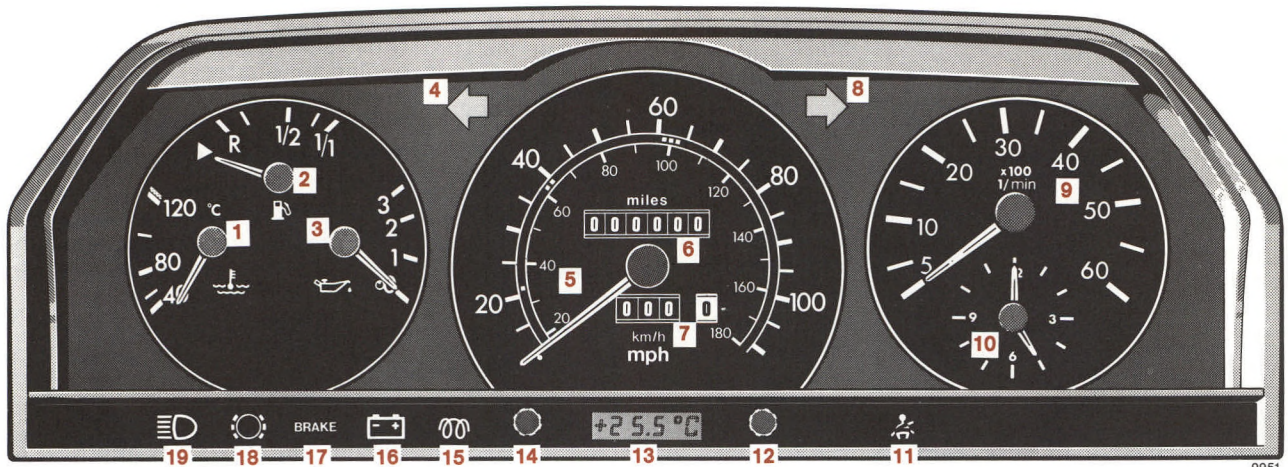

9951



Starting and Turning off the Engine

Engage parking brake before starting the engine.

Move gearshift lever to neutral (selector lever positions “P” or “N” on automatic transmissions).

Cold Engine

Turn key in steering lock to position 2. Charge indicator and preglow indicator lamp must come on. The preglow process starts. When the preglow indicator goes out, the engine is ready for starting.

Ambient Temperature exceeding 0° C/ +32° F:

Turn key in steering lock clockwise to the stop. Do not depress accelerator. Release key only when the engine is firing regularly.

Ambient Temperature below 0° C/ +32° F:

Depress accelerator and clutch pedal (if applicable) to the floor. Turn key in steering lock clockwise to the stop. Release key only when the engine is firing regularly and back off accelerator slowly.

Do not interrupt the starting process. If the engine is very cold it is possible that it will fail to start on subsequent attempts.

Hot Engine

Turn key in steering lock clockwise to the stop and start engine immediately without depressing the accelerator. Release the key as soon as the engine is firing regularly.

Turning off

Turn key in steering lock to position 0 and remove only when the vehicle has stopped.

Should the engine continue to operate with the key in steering lock position 0, refer to page 60.

With very high coolant temperatures (e.g. after driving on mountain passes), do not shut down the engine immediately but allow it to run at slightly increased idle speed for another 1–2 minutes approximately.

Notes

Due to the installed starter non-repeat unit, the key in the steering lock must be returned to 0 position before making a new starting attempt.

Observe the oil pressure gauge immediately after starting. In a very cold engine the oil pressure will only rise slowly, some time after the engine has started. Do not speed up the engine before pressure is registered on the pressure gauge.

The charge indicator lamp must go out as soon as the engine has started.

If the preglow indicator fails to light up, the preglow system is defective and should be repaired at a MERCEDES-BENZ service station at the earliest possible date.

In areas where temperatures frequently drop below –18° C/0° F, we recommend that a block heater is installed. Every MERCEDES-BENZ service station will advise you on this subject.

Hints for Driving

Power assistance

When the engine is not running, both the service brake and the steering are without power assistance. Under these circumstances, a much greater effort is necessary to steer or stop the vehicle.

Tires

Do not allow your tires to wear down too far. With less than 3 mm/ $\frac{1}{8}$ in of tread, the antiskid properties on a wet road are sharply reduced.

Depending upon the weather and/or road pavement, the traction varies widely.

Specified tire pressures must be maintained. This applies particularly if the tires are subjected to high loads (e.g. high speeds, heavy loads, high ambient temperatures).

Aquaplaning

Depending on the depth of the water layer on the road, aquaplaning may occur, even at low speeds. Avoid track grooves in the road and apply brakes cautiously in the rain.

Tire friction

A given speed at which a vehicle driven on dry roads can still be fully controlled must be reduced when the same vehicle is to be driven safely on a wet or icy road.

You should pay particular attention to the condition of the road as soon as the prevailing temperatures fall close to the freezing point.

If ice has formed on the road tire traction will be substantially reduced. Under such weather conditions, drive, steer and brake particularly carefully.

We recommend M+S radial-ply tires for the cold season. On packed snow, they can reduce your stopping distance as compared with summer tires. Stopping distance, however, is nevertheless considerably greater than when the road is wet or dry.

Brakes

When driving down long and steep declines, relieve the brakes by shifting into a lower speed (selector lever position "3" or "2" in the case of automatic transmissions). This prevents overheating of the brakes and reduces brake pad wear.

After hard braking it is advisable to drive on for some time so the air stream will cool down the brakes faster.

When driving in heavy rain for some time without applying the brakes, the first braking action may be somewhat reduced and increased pedal pressure may be necessary. For this reason, stay further away from vehicle in front.

The condition of the parking brake system is checked each time the car is in the shop for maintenance.

Between maintenance checks it is a good practice to apply the parking brake once or twice while driving at approximately 50 km/h/30 mph on a dry road. Apply brake lightly until a slight drag on the wheels is felt. Keep applying brakes for about 10 seconds while holding release button in before releasing parking



brake completely. This practice will keep the parking brake at maximum efficiency.

Warning:

The stop lamps will not come on when applying the parking brake only. Apply parking brake only when road behind vehicle is clear of traffic.

All checks and maintenance work on the brake system should be carried out by a MERCEDES-BENZ dealer.

If the parking brake is released and the brake warning lamp in the instrument cluster stays on, the brake fluid level in the reservoir is too low.

Brake pad wear or a leak in the system may be the reason for low brake fluid in the reservoir.

Have the brake system inspected at a MERCEDES-BENZ service station without delay.

Install only brake pads recommended by us.

If other than recommended brake pads are installed, the braking properties of the vehicle can be affected to an extent that the safety is substantially impaired.

Driving Hints During the Winter Season

The most important rule for slippery or icy roads is to drive sensibly and to avoid abrupt acceleration, braking and steering action. Do not use the cruise control system under such conditions.

When the vehicle is in danger of skidding, declutch or – in case of an automatic transmission – move selector lever to position “N”. Try to keep the vehicle under control by means of corrective steering action.

Provided the traffic conditions will allow, only brake in a way that the wheels are locked for no more than fractions of a second as otherwise the steerability of the vehicle is lost.

Road salts and chemicals can adversely affect braking efficiency.

Increased pedal force may become necessary to produce the normal brake effect. We therefore recommend depressing the brake pedal repeatedly when travelling on salt-strewn roads at length. This can bring road salt impaired braking efficiency back to normal. A prerequisite is, however, that this is possible without endangering other drivers on the road.

If the vehicle is parked after being driven on salt treated roads, the braking efficiency should be tested as soon as possible after driving is resumed while adhering to the safety requirements.

MERCEDES-BENZ Maintenance System

A maintenance booklet is delivered with your car listing all the maintenance jobs that must be carried out after the following mileages:

Routine Maintenance

Inspection at
1300–1600 km/800–1000 miles
Lubrication Service every
8000 km/5000 miles
Maintenance Service every
24 000 km/15 000 miles
Additional Work every
48 000 km/30 000 miles

In the case of low mileage operation, the Maintenance Service must be carried out at least once every 2 years.

Engine Oil and Filter Change

Required every 8000 km/5000 miles, or at least once a year when using year-round multigrade oil; otherwise at least twice a year (spring and fall).

Under severe operating conditions or if diesel fuels with high sulphur content (in excess of 0.5% by weight) are used, the oil and filter should be changed every 4000 km/2500 miles.

For engine oil recommendations, see page 82.

Severe Operating Conditions

In the case of severe operating conditions or heavy use mainly in city traffic or over short distances, frequent mountain driving, poor roads, dusty and muddy conditions, trailer operation, hard and sporty driving etc., it may be necessary to carry out maintenance work at shorter than normal intervals, e.g.:

Engine: Oil change with filter change every 4000 km/2500 miles

Automatic transmission: Fluid change with filter change every 24 000 km/15 000 miles

Tires: Inspect

Air cleaner: Clean or replace element

Non-scheduled MB Maintenance Service

Every 24 000 km/15 000 miles Maintenance Service consists of 3 sections (General and Lubrication Service, Engine Maintenance, Safety Inspection). Performance of these sections can be requested individually if particular driving conditions so require, or on a precautionary basis before leaving for a long trip.

Special Maintenance Measures

Brake fluid should be replaced annually, preferably in spring.

The coolant should be checked for sufficient protection before the start off and during the cold season. Have the coolant (water/anti-corrosion/antifreeze mixture replaced not later than after three years (see “Fuels, Coolants, Lubricants, etc.”).

Maintenance Vouchers

Your MERCEDES-BENZ service station will certify in the maintenance booklet that all lubrication and maintenance services have been carried out at the correct intervals.

Stickers to remind you when the next lubrication service or maintenance service is due, or when the brake fluid must be changed, are provided in the middle of the maintenance booklet.

Sticker attaching points

In the frame of the driver's door: Lubrication service and maintenance service

In the engine compartment: Brake fluid change







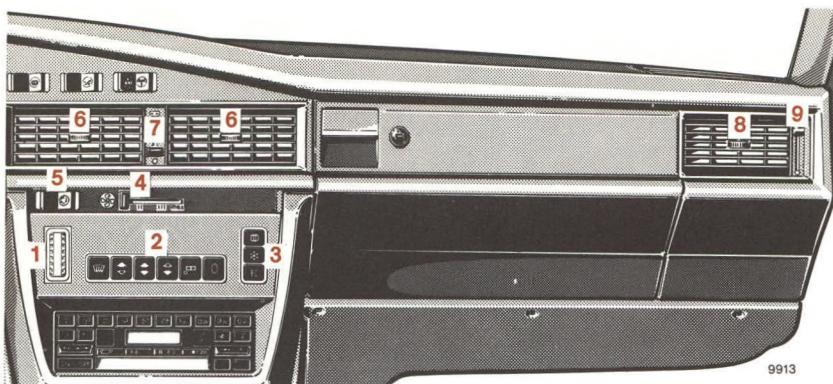

Operation

Tempmatic Climate Control System	18
Keys	24
Opening the Doors	25
Locking and Unlocking of Doors	25
Central Lock System	26
Adjustment of Driver's Seat and Front Passenger's Seat	27
Orthopedic Seat Backrest	28
Safety Head Restraints	28
Arm Rest (Rear Seat)	29
Arm Rest (Front Seats)	29
Heated Seats	30
Seat Belts	31
Steering Lock	33
Lighting Switch	34
Combination Switch	35
Exterior Mirrors	36
Inside Rear View Mirror	36
Sun Visors	37
Interior Lamps	37
Rear Window Defroster	38
Lighter	39
Sliding Roof	39
Power Windows	40
Shelf below Rear Window	40
Electronic Radio	41





Tempmatic Climate Control System

- 1 Temperature selector wheel
- 2 Air distribution control push buttons (press only one button at a time)

-  = Defrost or fast defogging
-  = Defogging inside glass
-  = Heating and cooling
-  = Normal heating
-  = Normal cooling or fresh air ventilation
-  = No fresh air supplied

- 3 Air conditioning mode control (press only one button at a time)

-  = Max. cooling
-  = Normal setting
-  = Economy setting (No A/C)

- 4 Fan speed control lever
- 5 Air recirculation switch
- 6 Instrument panel center outlets
- 7 Air volume lever for center outlets (6)
- 8 Instrument panel side outlets
- 9 Air volume lever for side outlets (8)

The button symbols light up when the vehicle's head lamps are turned on (not with parking lamps). The symbol is brighter when depressed.

The engine must be running for the air conditioning system to work.

Close all windows and the sliding roof to ensure proper operation of the system. Air outlet temperature is controlled automatically.

Note:

The air conditioner removes considerable moisture from the air during operation. It is normal if water drips on the ground from under the car.

Air Distribution

Air conditioned, warmed, or fresh air may be directed to the foot area, the windshield, and the side outlets (8). The center outlets (6) are for non-heated air only.

The air volume through the center outlets (6) and side outlets (8) may be changed with levers (7) and (9) respectively. Pushing the lever up opens the air outlets completely.



Temperature Selection

Use the temperature selector wheel to set the desired temperature. The selected temperature is reached as quickly as possible and maintained. Use a basic setting of "22". Refine your setting only in small steps to avoid large temperature fluctuations.

"MIN" (notched-in) = maximum cooling or fresh air dependent on push button selection of the air conditioning mode control.

"MAX" (notched-in) = maximum heating.



A/C Mode Control Switch

Position  (Economy) = Economical setting.

In this setting the air conditioning compressor stays off. Temperature regulation is maintained only during the heating phase.





Position  = Normal cooling, the air conditioning compressor is switched on.

The vehicle may be heated or cooled as desired. The compressor comes on as soon as the vehicle's interior temperature exceeds the selected temperature. The selected temperature is then maintained by regulating the compressor on-time.

Position  = Max. cooling, the air conditioning compressor is switched on.

The climate control system works at maximum capacity, removing moisture from either fresh air or recirculated air and defogs inside glass. The max. cooling mode, is recommended during humid weather and when windows must be defogged from inside.

Fan Speed Selection

When pushing one of these buttons , ,  or button , the fan speed will correspond to the particular position of lever (4).

The volume of fresh air supplied to the vehicle interior can be increased by pushing lever (4) to the right.



The fan speed may be changed by moving lever (4) to position "II", "III" or "max". The fresh air intake may be temporarily closed (press push button ) if driving through dusty areas or annoying odors enter the car interior.

Function  = Continuous max. air volume.

Air Recirculation Switch

Pressing the switch (symbol-side) down, causes air to be recirculated with only a small amount of fresh air. The indicator lamp should be on (do not push  button). This setting can also be used if annoying odors are entering the car's interior. At high outside temperatures the air conditioning system is automatically switched on, providing increased cooling of the recirculated air.

Fast Cooling

- Turn temperature selector wheel (1) and lock in extreme end position "MIN".
- Push button  or  in climate control switch (3).
- Push  button.
- Push lever (4) to far right "max" position.
- For maximum air flow push up levers (7) and (9).
- Close windows and sliding roof completely.

Open the windows and/or sliding roof long enough to let hot air inside the car escape. This helps reduce the time the air conditioner must run before the car cools. Then, close windows and/or sliding roof and allow air conditioner to operate normally.

Examples of Air Flow Adjustments

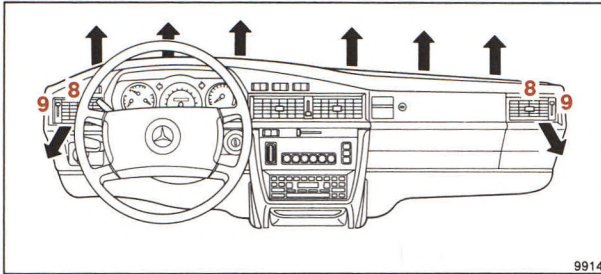

 Press to defrost or quickly defog windows.

Maximum heated air is directed to the windshield and side windows, independent of the temperature dial (1) setting, climate control switch (3) and lever (4) position. The air volume through outlets (8) may be adjusted with levers (9) as desired.

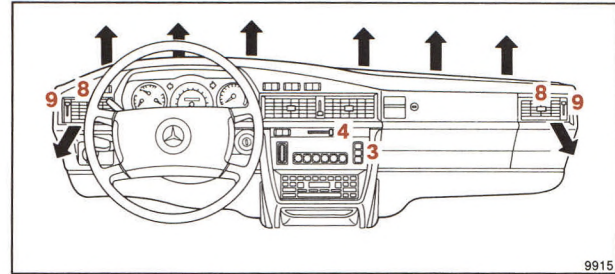

 Press to defog the windshield from inside

Air is directed to the windshield in the heating or cooling mode. Press button  of climate control switch (3) and increase fan speed for a short period with lever (4). Adjust levers (9) for the desired air flow through outlets (8).

It is possible for condensation to form on outside of the windshield in humid weather in this mode. If this happens, change the air flow or decrease the fan speed.

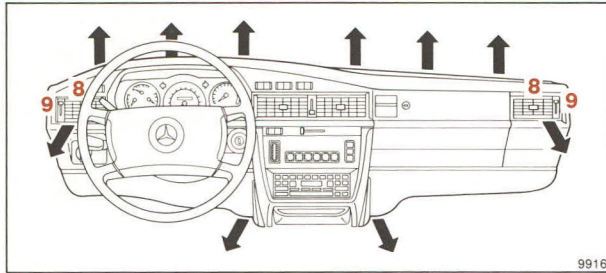

9916

 Press for heating with air conditioned air.

In this type of operation, air is directed to the windshield and the foot area. The air outlets (8) may be opened or closed with levers (9) as desired.

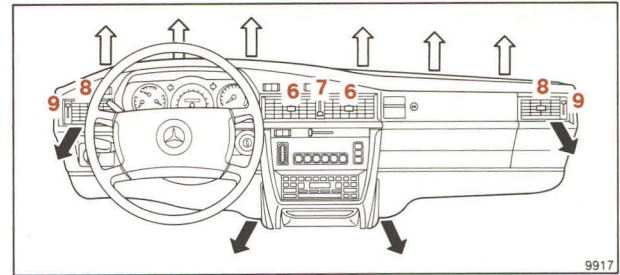

9917

 Press for normal heater operation.

Most of the air is directed to the foot area during heater operation. A small amount of air is directed to the windshield, just enough to keep it from fogging up during normal weather conditions. The air outlets (6) and (8) may be opened or closed with levers (7) and (9) respectively as desired. Only non-heated air is directed through outlets (6).

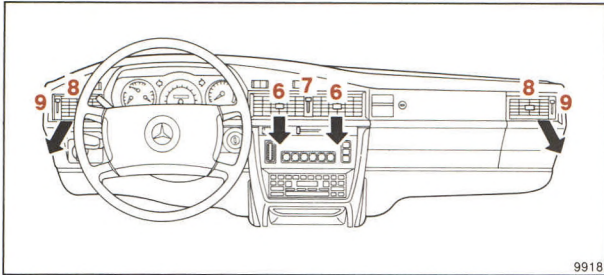

B Press for fresh air ventilation or air conditioning.

For taking in fresh air or during air conditioner operation, the air is directed to outlets (6) and (8). Adjust the air flow with levers (7) and (9) respectively as desired.

0 Press to shut off air entry.

Fresh air into the vehicle is shut off. Use this button to prevent outside odors, or water from car washes from entering the vehicle's interior, for example. Do not drive the vehicle with this setting for long periods with windows and sliding roof closed since the vehicle's normal interior airflow will be disrupted.

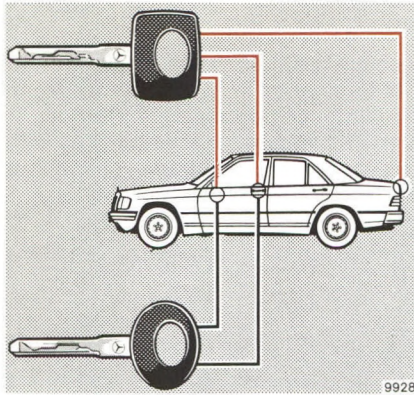

Master Key – square head – fits all locks on the car.

Supplementary Key – rounded head – fits only the door locks and the steering lock. This key is intended to be used whenever the car is left with an attendant. Be sure to lock glove compartment and trunk with the master key.



Flat Key

The flat key fits all vehicle locks. We recommend that you carry the flat key with you and keep it in a safe place so that it is always handy, if needed (e.g. in your wallet). Never leave the flat key in the vehicle.

Obtaining Replacement Keys

You are given 4 keys with your vehicle. Replacement keys can be obtained only via MERCEDES-BENZ service stations. For security reasons, obtaining replacement keys requires considerable time.

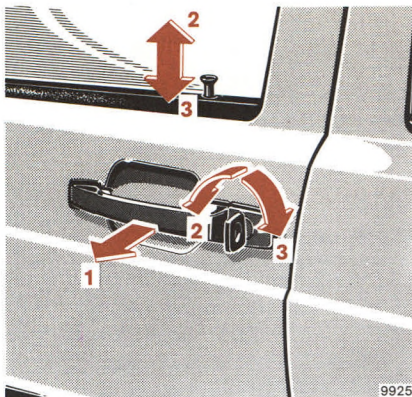

Opening the Doors

From outside: pull handle outwards (1).

From inside: pull handle in door trim panel (4).

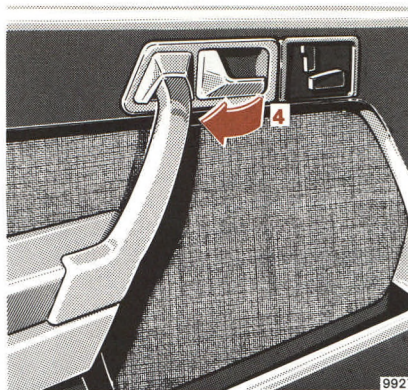

Locking and Unlocking of Doors

From the outside: turn key.

From the inside: actuate button.

2 Unlocking

3 Locking

When the rear door buttons are pushed down, the rear doors cannot be opened from the outside or the inside. They can be opened after pulling buttons up.

One cannot lock:

- the driver's door if it is open.
- any door if the door lock has not engaged fully. In this case open the door and close it again.



Central Lock System

The central lock system locks or unlocks the driver's door, the other vehicle doors, the fuel tank filler flap and the trunk lid simultaneously. The lock buttons of the other vehicle doors must then move together with the lock button of the driver's door. If this does not happen, the lock of the respective door is not properly engaged. Open the door again and shut it correctly.

The front passenger door and the rear doors can also be locked or unlocked individually from inside. The front passenger door can also be locked and unlocked with the key.

With the central lock system in the locked position, the trunk lid can also be unlocked individually: To do so, turn the master key to the left as far as it will go, then depress the trunk lid lock push button with the key and open the trunk. Turn the key to its initial position and withdraw it. To lock the trunk lid, close it firmly; the trunk lid will then be locked by the central lock system again.

The trunk lid can also be locked independently (for instance, to leave the vehicle in a workshop) without actuating the central lock system.

Turn the master key to the right as far as it will go and withdraw it. In this case the trunk lid can only be unlocked with the master key which must be inserted and turned back to the left.

Note:

If the fuel tank filler flap cannot be opened, refer to "Unlocking of Fuel Filler Flap" (page 69).



9710

Adjustment of Driver's Seat and Front Passenger's Seat

Manual:

Fore/aft adjustment: lift handle (1); slide seat to desired position and allow handle to re-engage.

Height of seat: raise lever (2); to raise seat, slide seat forward; to lower seat, slide seat backward; allow lever to re-engage.

Seat back position: turn handwheel (3). For full reclining of backrest, seat should be moved to one of the forward-most positions and head restraint removed. For driving, return backrest to upright position and push seat back. Replace head restraint.

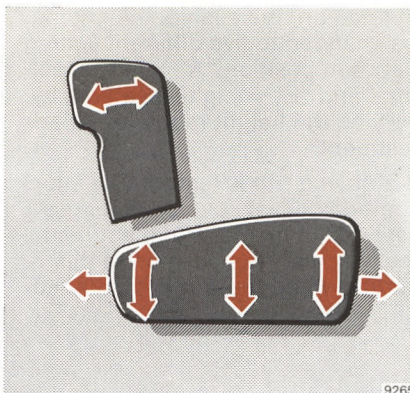

9265

Power:

Turn key in steering lock to position 2.

Seat and seat back can be adjusted individually by means of the switches. These are accommodated in the front doors.

When the key is withdrawn or turned to steering lock positions 1 or 0, seat and seat back can be adjusted only if the driver's door is open, to allow for easier entry to and exit from the vehicle.

Note:

Prior to operating the vehicle, the driver should adjust the seat height for proper vision as well as fore/aft placement and seat back angle to insure adequate control, reach, operation, and comfort. Be certain seat is "locked in" by sliding front/rear until full engagement is assured.

The head restraint should also be adjusted for proper height so that when the cushion is tipped completely forward, it should form a cradle behind the seat occupant's head. Both the inside and outside rear view mirrors should then be adjusted for adequate rearward vision. Fasten seat belts. Children under the age of six or under the weight of 23 kg/50 lb should be seated in the back seat with an approved restraint system properly secured.

All seat, head restraint, and rear view mirror adjustments as well as fastening of seat belts should be accomplished before the vehicle is put into motion.

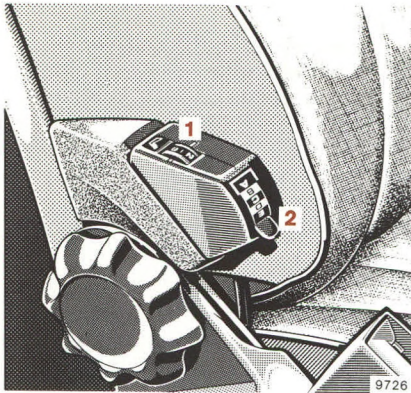

Orthopedic Seat Backrest

The seats have an inflatable air cushion built into the backrest to provide additional spinal cord support. The amount of cushion height and curvature may be adjusted after turning the ignition key to position 2.

The inflation pressure of the air cushion may be continuously varied between position “0” = without pressure, and position “4” = maximum pressure, by changing the pressure regulator (1) setting.

In addition, the cushion height may be changed to five different settings between position “A” = lowest setting, and “E” = highest setting, by varying the height regulator (2) adjustment.

If a driving trip is temporarily interrupted, the last cushion setting is retained in memory, and automatically adjusts the cushion to this setting when the trip is continued.

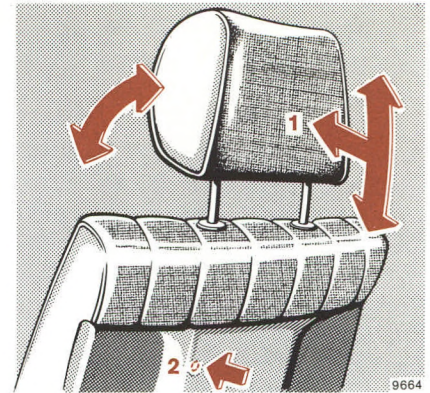

Safety Head Restraints

Adjust head restraint to support the back of the head approximately at ear level.

Safety head restraints, front
Height adjustment:

Press head restraint slightly forward (1) and slide upward or downward as required.

Removing head restraints:

Pull head restraint up to the stop. Depress release button (2) to be felt under the seat back covering material and pull head restraint up quickly, holding it by the LH head restraint post (viewed in driving direction). Then pull out head restraint completely with both hands.

Safety head restraints, rear

Height adjustment:

Raise or lower head restraint as required.

Removing head restraints:

Pull up head restraint until resistance can be felt. Then pull it out quickly using both hands.

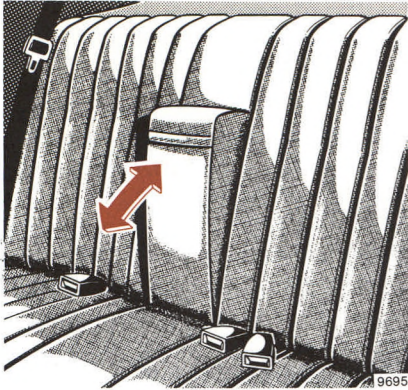

Arm Rest (Rear Seat)

The rear seat is equipped with an arm rest, which may be pulled out by the loop.

For removal of rear seat cushion, see "Practical Hints".

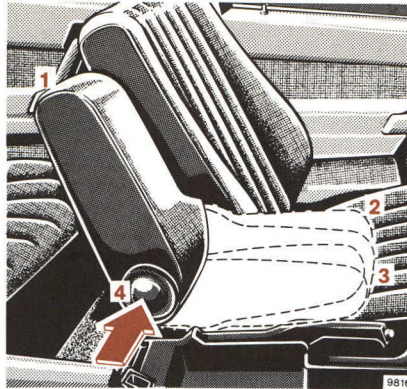

Arm Rest (Front Seats)

The arm rest engages in 3 positions.

Position 1 = arm rest folded up.

Position 2 = for normally inclined seat back.

Position 3 = for extremely inclined seat back.

For downward adjustment of the arm rest, depress release button (4).

Warning:

The arm rest does not suffice as a child restraint system. In case of a frontal collision a child can be catapulted forward over the locked arm rest.

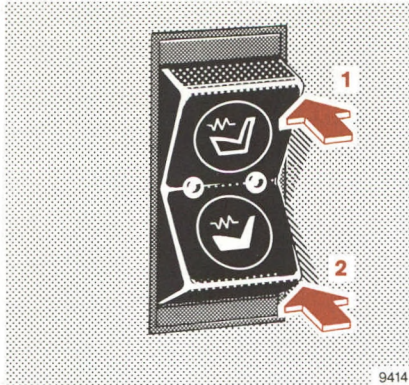

Heated Seats

The heaters can be turned on after first turning the ignition switch to position 2.

Heater operation:

Push in upper switch portion; position 1 = normal heater operation, one indicator lamp lights up.

Push in lower switch portion; position 2 = rapid heating, both indicator lamps light up.

After approximately 5 minutes in the rapid heating mode, the heater automatically switches to normal operation and only one control lamp will stay on.

Turning off heater:

If one control lamp is on, press in upper part of switch, position 1.

If both control lamps are on, press in lower part of switch, position 2.

The heater automatically turns off after approximately 30 minutes of operation.

Note:

When in operation, the seat heater consumes a large amount of power. It is advisable not to use the seat heater longer than necessary.

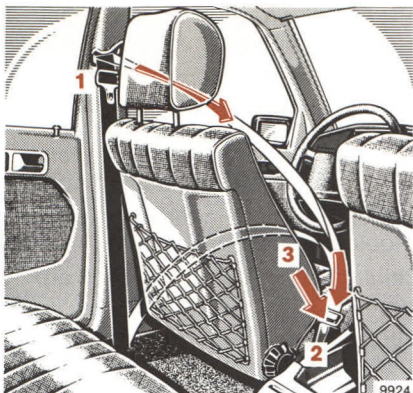

Seat Belts

Warning system:

The indicator is illuminated for 4–8 seconds after turning the steering lock key to position 2. If the seat belt of the driver's seat is not fastened a warning buzzer sounds simultaneously.

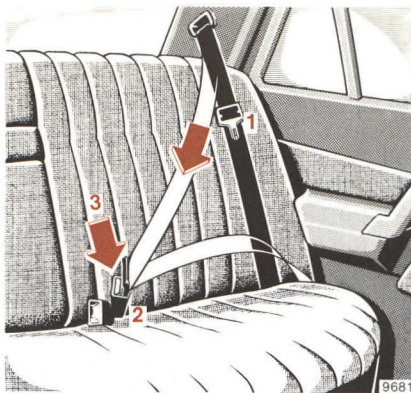

Fastening:

- Pull belt with latch plate (1) over shoulder and lap. The belt must not be twisted.
- Press latch plate (1) into buckle (2) and allow to engage audibly.
- The belt must be tight and must be checked for tightness immediately after fastening and regularly during the trip. If required, tighten lap belt by pulling up on the upper belt section.

Unfastening:

- Depress red button (3) in buckle.
- Return latch plate (1) to initial position.

Operation:

The seat belt inertia reel stops the belt from unwinding further in case of vehicle deceleration in any direction or if the belt is pulled out quickly.

Functional test:

The locking function of the inertia reel can be tested by pulling the belt out quickly.

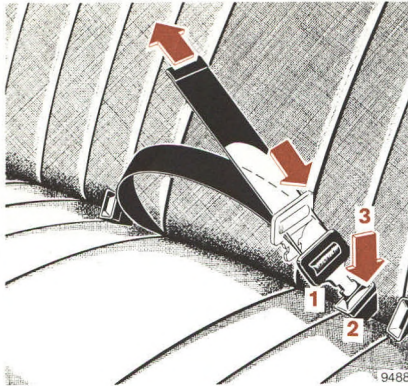

Lap belt in rear passenger compartment:

Pull belt with latch plate (1) across the lap, press latch plate in lock (2) and allow to engage audibly. The belt must not be twisted but must be tight.

To shorten the belt, pull belt end with the tongue engaged. To lengthen the belt, turn the latch plate so that it is at a little more than 90° to the belt and pull before fastening the belt.

To disengage the belt, push red button (3) in the lock.

Note:

No seat belt can be used for more than one person. Children under the age of six or under the weight of 23 kg/50 lb should be seated in the back seat with an approved restraint system properly secured.

After an accident, inspect the seat belts and replace them, if required.

Child restraint systems recommended by us can be fastened to the seat belts installed. Any MERCEDES-BENZ service station will gladly advise you accordingly.

The belt anchors in the vehicle should also be checked.

Belts must not be routed via sharp edges.

Replace damaged seat belts immediately.

No modifications which may affect the efficiency of the belts must be made.

For cleaning and care of belt webbing, refer to page 73.

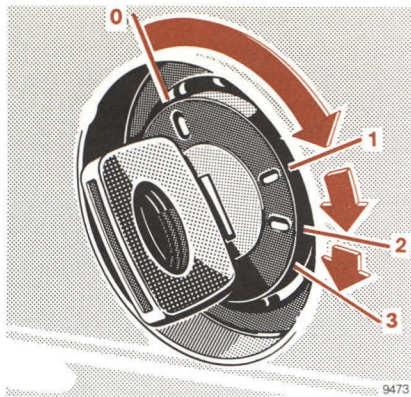

Steering Lock

- 0 Steering is locked when the key is withdrawn and the steering lock is engaged. The key can be withdrawn only in zero position.

Note:

Do not remove key from steering lock while the vehicle is in motion as this will cause the engagement of the steering lock thus rendering the vehicle inoperable.

- 1 Steering is unlocked.
(If necessary, move steering wheel slightly to turn the key clockwise to position 1.)
- 2 Preglowing and driving position.
- 3 Starting position.

For starting and turning off the engine, refer to page 12.

Notes:

The following items can be operated with the key in steering lock position 1:

Wiper, windshield washer, head-lamp flasher, electric lighter, glove compartment lamp, radio, electric sliding roof drive, rear window defroster, power windows.

A warning buzzer sounds when the key has been left in steering lock positions 1 or 0 and the driver's door is opened.

With the engine at idle speed, the charging rate of the alternator (output) is limited.

It is therefore recommended to turn off unnecessary electrical consumers while driving in stop and go traffic. This precaution helps to avoid draining of the battery.

Unnecessary strain on the battery and charging system may be minimized by turning off the following power consumers, for example: Heater in heated seats, rear window defroster.

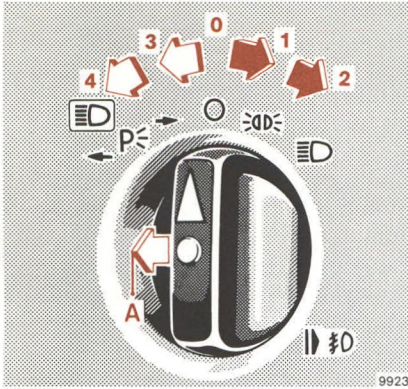

Lighting Switch

- 0 Off-position
- 1 Parking lamps (includes side marker lamps, tail lamps, license plate lamps, instrument panel lamps)
- 2 Same as pos. 1 plus headlamps
- 3 Standing lamps, right
- 4 Standing lamps, left
- A Turn to position 2 and pull out to first detent = same as position 2 plus fog lamps

Note:

With the steering lock key removed and the driver's door open a warning buzzer sounds if the vehicle's exterior lamps are not switched off (standing lamps excepted).

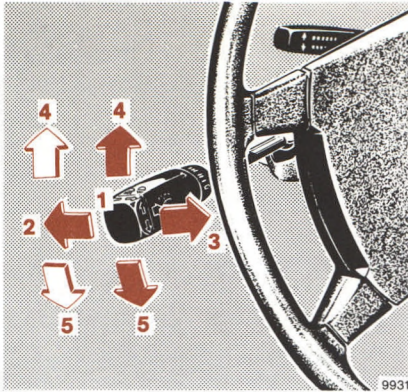

Combination Switch

- 1 Low beam (turn lighting switch clockwise two notches)
- 2 High beam (turn lighting switch clockwise two notches)
- 3 High beam flasher (high beam available independent of lighting switch position)
- 4 Turn signals, right
- 5 Turn signals, left

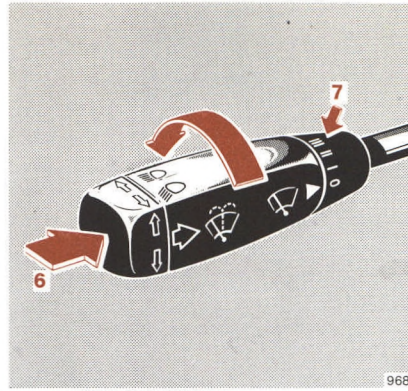

- 6 Control for windshield washer system

When the washer system is switched on, the wipers also operate.

- 7 Windshield wiper control
 - 0 Windshield wiper switched off
 - I Intermittent wiping
 - II Normal wiper speed
 - III High wiper speed

Hints:

If one of the turn signals fails, the turn signal indicator system flashes and sounds at a faster sequence than under normal operating conditions.

Fog lamps will only operate together with low beam headlamps. Fog lamps are turned off automatically when lighting switch is returned to off-position.

To operate the turn signals, move the combination switch past the point of resistance (up or down). The switch is automatically canceled when the steering wheel is turned by a large enough angle.

To signal minor directional changes of the vehicle, such as changing lanes on a highway, move combination switch to the point of resistance only and hold it there.

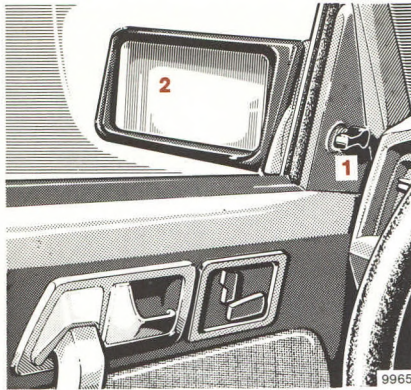

Exterior Mirrors

Driver's side:

The exterior mirror (2) can be adjusted from inside the vehicle by moving adjusting lever (1) in the desired direction.

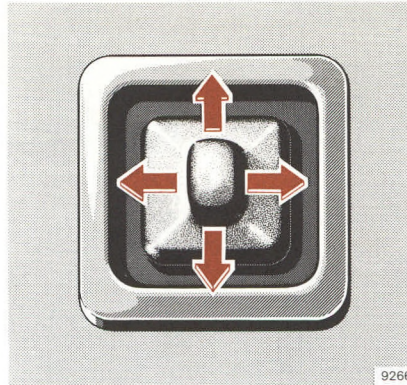

Passenger side:

Turn key in steering lock to position 2. The exterior mirror can be adjusted by means of the switch.

Note:

If the mirror housing has been forcibly moved from its normal position, it must be repositioned by applying firm pressure.

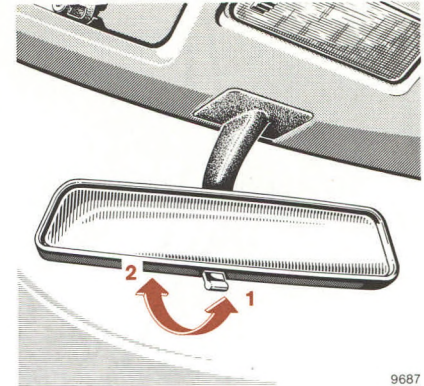

Inside Rear View Mirror

The mirror can be tilted to the anti-glare night position by means of the lever at its lower edge.

1 = Normal position

2 = Anti-glare night position

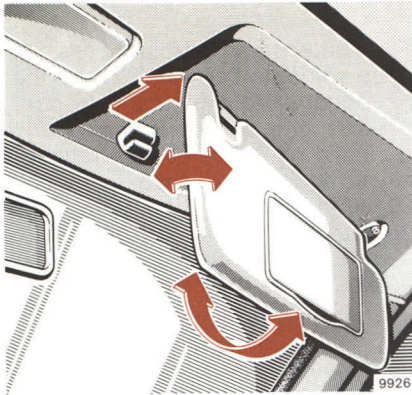

Sun Visors

Swing sun visors down to protect against sun glare.

If sunlight enters through the side window, disengage visor from inner mounting and swing to the side.

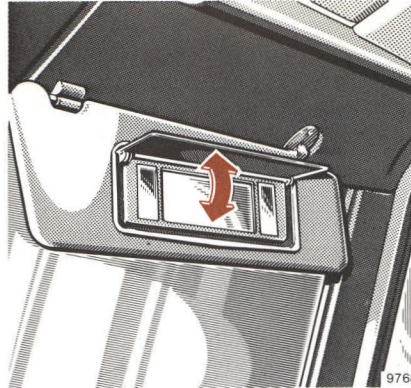

Vanity mirror:

Swing down sun visor. The lamps are switched on when the cover is opened. For this purpose the visor must be engaged in its inner mounting.

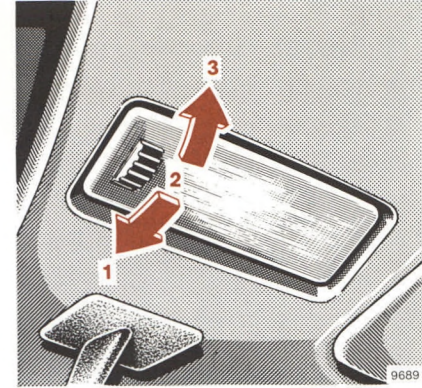

Interior Lamps

The switch for the front lamp has 3 positions.

Position 1: the lamp is switched on and off (delayed) by the front door contact switches.

Position 2: lamp switched off permanently.

Position 3: lamp switched on permanently.

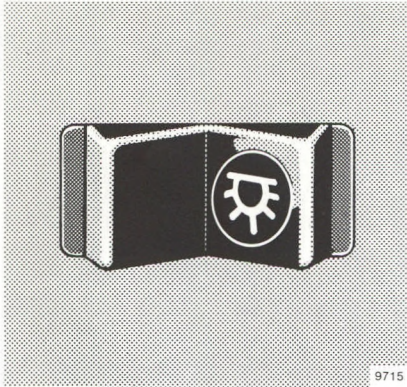

The rear courtesy lamp is switched on and off by the rear door contact switches or by the rocker switch on the instrument panel.

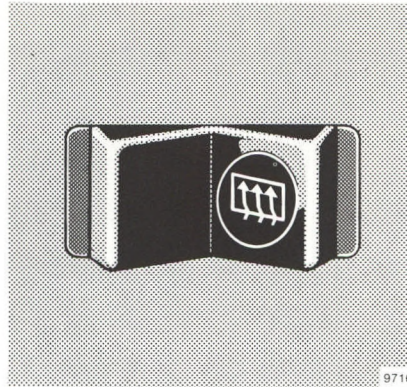

Rear Window Defroster

With engine running, press rocker switch to right to turn on, to left to turn off.

When activating the rear window defroster, the indicator lamp inside the switch will come on.

Note:

The rear window defroster uses a large amount of power. To keep the battery drain to a minimum, turn off the defroster as soon as the window is clear. The defroster is automatically turned off after a maximum of 20 minutes of operation. Heavy accumulation of snow and ice should be brushed and cleaned off before activating the defroster.

If several power consumers are turned on simultaneously, or the battery is only partially charged, it is possible that the defroster automatically turns itself off. When this happens, the indicator lamp inside the switch starts blinking. As soon as the battery has sufficient voltage, the defroster automatically turns itself back on.

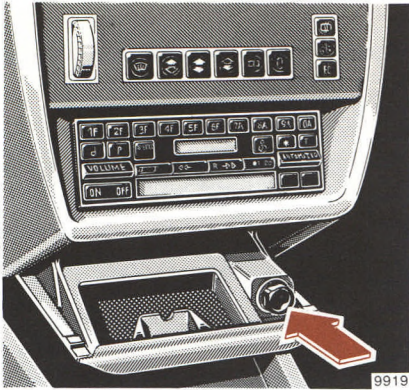

Lighter

Turn key in steering lock to position 1 or 2.

Press in lighter; it will pop out automatically when hot.

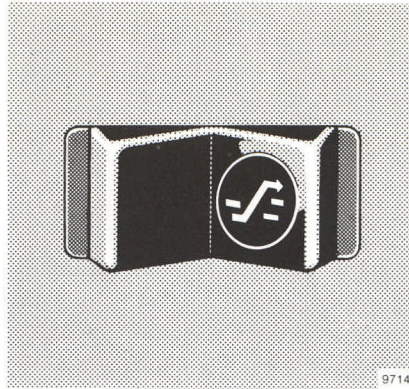

Sliding Roof

Turn key in steering lock to position 1 or 2.

Press symbol-side of rocker switch to open roof. Press left side to close roof.

If the electric drive fails, the sliding roof can also be moved by hand. Refer to "Emergency Operation of Sliding Roof" (page 69).

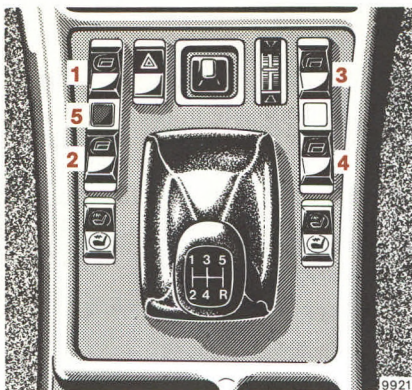

Power Windows

Switch group for power windows:

- 1 front, left
- 2 rear, left
- 3 front, right
- 4 rear, right
- 5 Safety switch

The power windows can only be operated with the steering lock in position 1 or 2.



Shelf below Rear Window

The shelf below the rear window should not be used to carry objects. This will prevent such objects from being thrown about and injuring vehicle occupants during an accident or sudden maneuver.

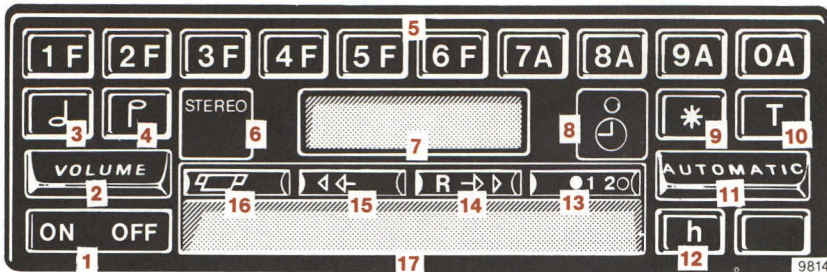

Electronic Radio

- 1 On/Off switch **ON OFF**
- 2 Volume control **VOLUME**
- 3 Bass control **J**
- 4 Treble control **P**
- 5 Push buttons for AM/FM band selection, station frequency selection, station presetting **1 F** through **0 A** and clock setting.
- 6 Stereo indicator lamp **STEREO**
- 7 Digital display panel for station frequency, station push button number, AM/FM band and time display **101.5 MHz 2**
- 8 Recessed button for setting time **⓪**
- 9 Function control button *****
- 10 Timer button **T** to control switch-on time of radio
- 11 Automatic or manual search station seeker bar **AUTOMATIC**
- 12 Time display call button **h**
- 13 Cassette track switch and track indicator **1 2 ⓪**
- 14 Fast tape rewind locking button **R → ⓪**

15 Fast tape forward locking button **← ⓪**

16 Cassette eject button **⓪**

17 Cassette door **|||||**

To turn the radio on or off, the ignition switch must be in position 1 or 2.

To turn the radio ON

Press “ON” side of **ON OFF** switch.

The radio will begin operating on the last station tuned to and the last volume and tone setting stored before last turn off.

The radio can also be turned on by inserting a tape cassette through the cassette door.

To turn the radio OFF

Press the “OFF” side of the **ON OFF** switch.

Volume adjustment

To reduce volume, press volume switch **VOLUME** downward; to increase volume, press switch **VOLUME** upward.



An additional fader control, installed in the center console of the car, allows for distribution of the audio power between the front and rear speakers.

To adjust the tone characteristic

To set the radio to a “flat” frequency response, briefly press both tone controls **J** **P** simultaneously.

To produce more bass, press the bass control only **J**. To produce more treble, press the treble control only **P**.

Note:

Repeated pressing of either the bass or treble control will cause the respective tone control to alternate between an increasing and decreasing setting.

To select AM or FM

Press any of the buttons marked **1F** through **6F** to tune the radio to the FM band.

Press any of the buttons marked **7A** through **0A** to tune the radio to the AM band.

To tune to a station

Stations can be tuned in by using automatic search, direct frequency dialing, manual tuning, or by preset push buttons. The frequency of the station selected is displayed digitally on the display panel.

Automatic station search

Switch to the wave band desired by pressing any of the following buttons:

for FM, buttons **1F** through **6F**,
for AM, buttons **7A** through **0A**.

By pressing the automatic station seeker bar **AUTOMATIC** upward the radio will search for stations in ascending frequencies, by pressing down in descending frequencies. The direction of automatic searching can be reversed by pressing the bar **AUTOMATIC** in the respective direction. In order to arrive at a desired station faster, the bar has to be held down in the desired direction.

The radio is programmed to automatically search the entire band in three sensitivity modes. During its first sweep, only the most powerful stations received will be selected

and locked in. During the next sweep, the less powerful and during the third cycle, also the weak stations will be locked in.

If the station seeker bar is activated within 8 seconds, after the radio is tuned to a station, then the search operation will be continued at the same sensitivity level. If 8 seconds are exceeded, the radio will revert to searching only the most powerful stations.

Direct frequency dialing

In order to select a station with a known frequency, select the wave band, press the function button ***** and then enter the frequency by pressing the corresponding push buttons.

Example:

Press any button marked
Press the function button
Enter frequency by pressing

FM 98.5 MHz	AM 1050 KHz
1 F through 6 F	7 A through 0 A
*	*
9 A , 8 A , 5 F	1 F , 0 A , 5 F , 0 A

When dialing a frequency directly, the number of the push buttons is not displayed on the panel. The wave band is indicated by showing “MHz” for FM or “KHz” for AM.

Note:

All AM stations have allocated frequencies ending with a “0”.
All FM stations have allocated frequencies ending with an odd (uneven) digit after the decimal point.

Broadcasters sometimes may not give their exact frequency but the next closest even number.

US radio frequency ranges: Am 540–1600 KHz
FM 88.1–107.9 MHz

Manual tuning (used to fine tune a station or for manual scanning)

After selecting the desired AM or FM wave band, press the function control button *****.

Press automatic station seeker bar **AUTOMATIC** (up or down) and hold down. The frequency will increase or decrease respectively in increments of 0.1 MHz for FM or 1.0 KHz for AM. Release the button when the desired station is tuned in.

Unless the automatic station seeker bar **AUTOMATIC** is activated within 8 seconds after pressing the function control button *****, the manual tuning will automatically be deactivated.

Safety Note

To avoid distraction of attention from the vehicle’s operation and the road, it is recommended NOT to perform any manual tuning operations by the driver while the vehicle is in motion. Use the automatic station search operation or preset stations instead.

Push button tuning

Six FM stations and four AM stations can be stored in memory and recalled by pressing the appropriate buttons marked **1 F** through **6 F** for FM or **7 A** through **0 A** for AM stations.

To store stations in memory

Any FM station frequency displayed on the panel can be stored on any button marked **1 F** through **6 F** by depressing the button desired and holding it until the display has changed from the “old” setting to a “blank” and then to the new frequency to be stored.

Showing the “old” setting first allows for reconsideration of the decision to store. If it is desirable to leave the “old” frequency in memory rather than exchanging it with the “new” one, quickly release the button. The “old” frequency will remain in memory.

Any AM station can be stored similarly on any button marked **7A** through **0A**.

Stereo reception

The stereo indicator symbol **STEREO** lights up if a stereo program is received.

The radio is equipped with an automatic stereo/mono switch that electronically switches to mono for clear reception if a weak signal is received. A special circuit provides for a smooth change-over rather than a hard sudden switching, thereby reducing noise and interference.

The stereo indicator will remain lit even if the receiver has changed to the mono mode and will turn off at an antenna signal considered insufficient to provide acceptable reception quality.

Tape Cassette playback

It is recommended to use only good quality cassettes with a playback time of not more than 60 to 90 minutes (C 60) or (C 90).

To start playback, insert a cassette through the cassette door. Push the cassette in until it is locked in its playing position.

When the end of one playing side is reached, the unit switches automatically to reverse for playing the second track.

Manual reverse can be activated by depressing the cassette track switch button **1 2 0**. The built-in indicators show the track of the cassette the unit is playing back.

To stop playback, press the eject button **EJECT**. The unit will automatically eject the cassette and switch to radio reception.

For fast tape rewind press the fast rewind button **R →**. The button will lock into position until the end of the tape is reached or until the eject **EJECT** or fast forward **←** button is activated.

Accordingly, for fast forward transport of the tape, press the fast forward button **→**.

When the radio is turned off by pressing the “OFF” side of the **ON OFF** switch or by turning the ignition key off, the cassette will automatically be ejected.

Care and maintenance

To avoid a deterioration of the tone quality, occasionally clean the tape head with the special cleaner supplied in your glove compartment or available through your dealer.

To set clock

Turn ignition key to position 1 or 2. Briefly press recessed time set button **⊖** by using a pencil or ballpoint pen.

Enter the time at which you want to start the clock by sequentially pressing four of the top row push buttons **1 F** through **0 A**. The time entered will be displayed.

Note:

This is a 24 hour clock and time must be entered in all four digits. A 24 hour clock counts time from midnight to midnight, that is 24 hours. A time of 4:28 PM therefore is counted by this clock as 16:28 hours (12 plus 4:28 hours).

Example 1: To enter 7:30 AM, press buttons **0A**, **7A**, **3F**, **0A**

Example 2: To enter 4:28 PM, press buttons **1F**, **6F**, **2F**, **8A**

The time entered is now stored. To start the clock in accordance with a time signal or other time reference, again briefly press the recessed time set button **Ⓢ**.

A colon sign will appear between the second and third digits **07:30**, to indicate that the clock is activated.

Normally, the display panel will show the frequency the radio is tuned to.

To display time

Briefly press the call button **h**. The time will be displayed for a few seconds.

To use the timer **T**

By using the timer **T**, the radio can be automatically turned on at a preset time. In order to set the timer **T**, the ignition key must be in position 1 or 2. The timer **T** can only turn the radio on with the ignition switch in position 1 or 2.

Setting the timer

Press button **T** and key the desired turn-on time into the timer as explained under "setting of the clock". In order to start the timer, for instance, to turn the radio on at a preset time, press button *****. The fact that the timer has been started is shown by displaying a colon between the second and third digits of the time.

Whenever you wish to verify the time at which the timer is set, press button **T**. The time will be displayed in the panel. After a few seconds, the display will switch back to the station frequency. In order to change the timer to a new setting, refer to the above information.

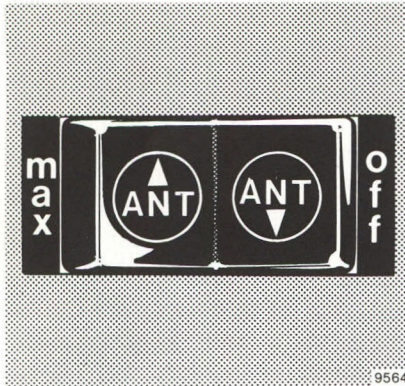

Automatic Antenna

The antenna switch can be actuated with the radio switched on and the key in steering lock positions 1 or 2.

- If the antenna switch is in the center position, the antenna extends automatically to medium height,
- if the antenna switch is engaged in the "max." position, the antenna extends fully,
- if the antenna switch is engaged in the "off" position, the antenna will not extend or will retract completely.

The height of the antenna can be adjusted to any intermediate by actuating the antenna switch:

- If the antenna switch is in center position, the antenna will extend to medium height. The antenna can be further extended or retracted to any height by rocking the switch (not engaging it).
- If the antenna is to be retracted, e.g. for playing cassettes, engage switch in "off" position.

When the key is turned to steering lock position 0 or the radio is turned off, the antenna will retract completely.

Driving

Parking Brake	48
Starting and Shifting Gears	48
Manual Transmission	48
Recommended Shift Points for Manual Transmission	48
Automatic Transmission	49
Cruise Control	51
Brake Pad Wear Indicator Lamp	52
Brake Fluid	52
Charge Indicator Lamp	52
Fuel Reserve Warning Lamp	52
Oil Pressure Gauge	52
Coolant Temperature Gauge	52
Emission Control	53
Engine Oil Consumption	53
High Altitude Correction Device	53
Traveling Abroad	53
Winter Driving	54
Tire Chains	54

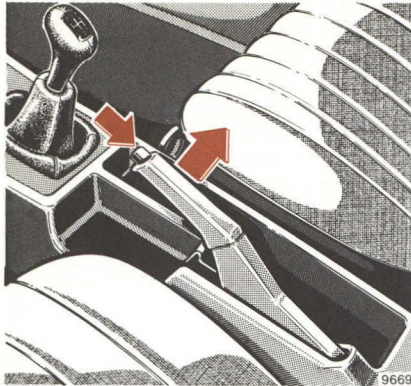

Parking Brake

Pull up parking brake lever. The brake indicator on the instrument cluster will come on when the ignition key is in position 2.

To release the parking brake, slightly pull up lever, push in lock button at the grip then lower it completely. The indicator lamp on the instrument cluster must go out, when lever is down.

Starting and Shifting Gears

Warning:

Keep driver's foot area clear at all times. Objects stored in this area may cause impairment of pedal movement.

Test the service brake before driving off.

Warm up the engine smoothly. Do not place full load on the engine until the operating temperature has been reached.

When taking off on a slippery surface, do not allow one driving wheel to spin for an extended period.

Manual Transmission

See figure for gearshift lever positions corresponding to the individual gears.

Shift into reverse gear only with the vehicle at a standstill; for this purpose press shift lever down and engage reverse gear shortly after de-clutching.

Do not exceed the maximum speed in the individual gears. See line markings on the speedometer.

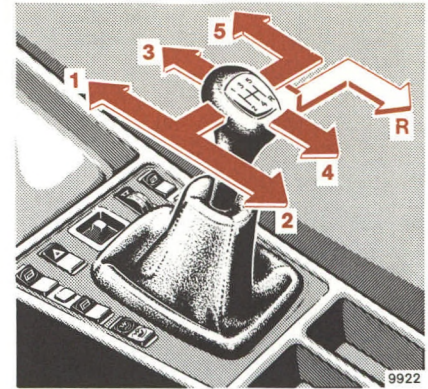

Note:

When vehicle is parked, be sure to engage first or reverse gear and set parking brake.

Recommended Shift Points for Manual Transmission

To obtain good results regarding fuel economy, the following shift points are recommended:

Shift

from 1st to 2nd at 21 km/h/13 mph
from 2nd to 3rd at 39 km/h/24 mph
from 3rd to 4th at 53 km/h/33 mph
from 4th to 5th at 79 km/h/49 mph.

Automatic Transmission

The automatic transmission simplifies the handling of the vehicle. The individual gears are shifted automatically dependent upon selector lever position, vehicle speed and accelerator position.

Hint:

When vehicle is parked or being worked on with engine running, be sure to set parking brake and that selector lever is in position "P".

Driving:

Shift selector lever to the desired driving position only when the engine is idling and the service brake is applied. Do not release the brake until ready to drive. The vehicle may otherwise start creeping when the selector lever is in a driving position.

Accelerator position

Partial throttle = early upshifting = normal acceleration

Full throttle = later upshifting = maximum acceleration

Depressing the accelerator beyond full throttle to kickdown position means downshifting to the next lower gear and thus maximum acceleration. If you ease up on the accelerator after having attained the desired speed, the transmission will shift up again.

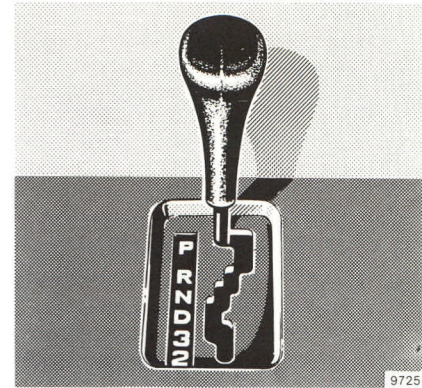

Selector lever positions

The automatic gear shifting process can be adapted to specific operating conditions by means of the selector lever.

"P" Parking lock.

The parking lock is an additional safeguard when parking the vehicle. Engage only with the car stopped.

"R" Reverse gear.

Shift reverse gear only with the car stopped.

“N” Neutral.

No power is transmitted from the engine to the rear axle. When the brakes are released, the vehicle can be moved freely (pushed, towed or tow-started). Do not engage “N” when driving except when the vehicle is in danger of skidding (e.g. on icy roads, see page 14).

“D” Drive.

Automatic upshifting to top gear. Position “D” affords optimum driving characteristics under all normal operating conditions.

“3” Slope.

Upshift to 3rd gear only. Suitable for medium range up or downgrades.

“2” Low.

Upshift to 2nd gear only. For driving in mountainous regions: Since transmission will not shift up further, this gear selection will make use of the engine’s braking power.

Important!

Do not exceed the speed limits for individual gear selections, which are correspondingly indicated by marks on the speedometer.

Do not attempt downshifting to a lower gear (braking effect) unless the speedometer needle is below the speed-limit-mark of that particular gear range. Over-revving could otherwise result in damage to the engine.

On slippery road surfaces, it is not recommended to downshift in order to obtain braking action.

Trailer operation

Do not allow the engine speed to drop too low at uphill gradients to prevent the engine from laboring at low RPMs. Depending on the degree of the incline, shift selector lever to positions “3” or “2” early enough to maintain engine RPMs within best torque range.

Stopping

For brief stops, e.g. at traffic lights, leave the transmission engaged and control vehicle with the service brake.

For longer stops with the engine idling, shift into “N” or “P”.

When stopping the car on a slope, do not hold it by means of the accelerator but use the brake. This avoids unnecessary heat-up of the transmission.

Maneuvering

To maneuver in a tight areas, e.g. when pulling into a parking space, control the car speed by gradually releasing the service brake.

Accelerate gently and do not pump the accelerator. To rock a car out of soft ground (mud or snow), alternately shift from forward to reverse, apply only partial throttle.

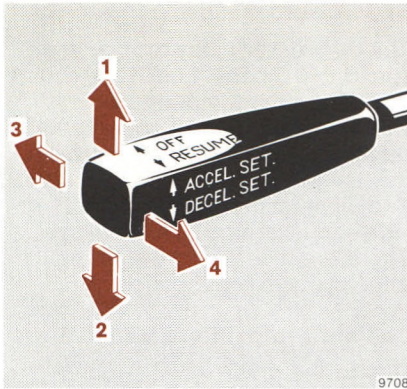

Cruise Control

Any given speed above approximately 40 km/h/25 mph can be maintained with the cruise control by operating the switch.

- 1 Setting (touch switch)
Accelerating (hold switch)
- 2 Setting (touch switch)
Decelerating (hold switch)

Normally the vehicle is accelerated to the desired speed with the accelerator. Speed is set by briefly pushing the switch to position 1 or 2, and the accelerator can be released.

The speed can be increased (e.g. for passing) by using the accelerator. As soon as the accelerator is released, the previously set speed will be resumed automatically.

If a set speed is to be increased or decreased slightly, e.g. to adapt to the traffic flow, retain switch in position 1 or 2 until the desired speed is reached. When the switch is released, the newly set speed remains.

- 3 Cancelling
To cancel the cruise control, briefly push lever to position 3. The cruise control will also be cancelled if the brake or clutch pedal is actuated or if the vehicle speed drops below 40 km/h/25 mph.

- 4 Resume
If the lever is briefly pushed to position 4 when driving at a speed exceeding approximately 40 km/h/25 mph, that speed is resumed which was set prior to the cancellation of the cruise control. The last memorized speed is cancelled when the key in the steering lock is turned to position 1 or 0.

Important:

Only use the cruise control if the traffic conditions make it advisable to travel at a steady speed.

Position "Resume" should be engaged only if the driver is fully aware of the previously set speed and wishes to resume this particular preset speed.

In the case of manual transmissions the vehicle maximum speed in the individual gears should not be exceeded. See line markings on the speedometer. In the case of automatic transmissions the selector lever must not be shifted to position "N" when driving with the cruise control engaged as otherwise the engine will overrev.

Brake Pad Wear Indicator Lamp

The brake pad wear indicator lamp in the instrument cluster stays on when the key in the steering lock is turned to driving position 2 and it must go out when the engine is running. If the indicator lamp lights up during braking, this shows that the front wheel brake pads are worn down.

Have brake system checked in a MERCEDES-BENZ service station as soon as possible.

Brake Fluid

Brake fluid should be changed once a year, preferably in spring.

Only use brake fluid recommended by us. For further information, refer to "Fuels, Coolants, Lubricants, etc."

When the minimum mark on the reservoir is reached, have the system checked (brake lining thickness, leaks).

Charge Indicator Lamp

Should the charge indicator lamp fail to come on prior to starting when the ignition key is in position 2 or should it fail to go out after starting or during operation, this indicates a fault which must be repaired at a MERCEDES-BENZ service station as soon as possible.

When the charging indicator lamp glows while the engine is running, the V-belt may have been torn off which makes the water pump also inoperative. This may cause overheating and damage to the engine. In this case the V-belt must be renewed before driving on.

Fuel Reserve Warning Lamp

The fuel reserve warning lamp will come on when the ignition key is turned to position 2, and will go out after the engine is running.

If the warning lamp stays on after the engine starts, or comes on while driving, it indicates that the fuel level is down to the reserve quantity.

Oil Pressure Gauge

The oil pressure may drop at idle speed to 0.3 bar/4.4 psi if the engine is at operating temperature. This will not jeopardize its operational reliability. Pressure must, however, rise immediately upon acceleration. The oil pressure gauge will not provide early warning of low oil level. Therefore, check oil level at regular intervals with the dipstick.

Coolant Temperature Gauge

Due to the pressurized cooling system, the coolant only starts boiling at a temperature of approx. 125° C/257° F with an anti-corrosion/antifreeze blended coolant fill protecting down to -30° C/-22° F (see also "Fuels, Coolants, Lubricants, etc.").

During severe operating conditions and stop-and-go city traffic the coolant temperature must not rise above the red marking.

Emission Control

Certain systems of the engine serve to keep the toxic components of the exhaust gases within permissible limits required by law. (Nevertheless, we urgently advise you not to let the engine run in a closed garage.) These systems, of course, will function properly only when maintained strictly according to factory specifications. Any adjustments on the engine should, therefore, be carried out only by qualified MERCEDES-BENZ technicians. The adjustments of the engine should not be altered in any way. Moreover, the specified service and maintenance jobs must be carried out regularly according to MERCEDES-BENZ servicing requirements. For details refer to the Maintenance Booklet.

Engine Oil Consumption

Engine oil consumption can only be determined after a certain mileage has been covered. During the break-in period, higher oil consumption may be noticed and is normal.

High Altitude Correction Device

The engine is equipped with an automatic high altitude correction device.

Traveling Abroad

Abroad, there is a widely-spread MERCEDES-BENZ service network at your disposal. If you travel into areas which are not listed in the index of your service station booklet, you should request pertinent information from your dealer.



Winter Driving

Have your car winterized in a MERCEDES-BENZ service station before the onset of winter.

- Engine oil change: If no “all-year-round” engine oil is used, fill with recommended winter oil. For viscosity and capacity, refer to “Fuels, Coolants, Lubricants, etc.” and last page.
- For diesel fuels, refer to page 86 and last page.
- Anti-corrosion/antifreeze in the coolant: Check anti-corrosion/antifreeze protection periodically. For capacity refer to “Fuels, Coolants, Lubricants, etc.”.

- Additive in the windshield washer system: Add windshield washer solvent to the water in the windshield washer system.
- Test battery: Battery capacity drops with decreasing ambient temperature. A well charged battery ensures that the engine can always be started, even at low ambient temperatures.
- Tires: We recommend M+S radial tires on all wheels for the winter season. Observe permissible maximum speed for M+S radial tires and the legal speed limit.

Tire Chains

Use only tire chains that are tested and recommended by us. Any MERCEDES-BENZ service station will be glad to advise you on this subject.

Chains should only be used on the rear wheels. Adhere to the manufacturer’s mounting instructions.

After driving a short distance re-tighten the mounted chains.

Tire chains should only be driven on snow at speeds not to exceed 50 km/h/30 mph. Remove chains as soon as possible when driving on roads without snow.

For tips on driving on slippery winter roads refer to page 14.

Practical Hints

Hood	56
Checking Coolant Level	57
Adding Coolant	57
Engine Oil Level Check	58
Fluid Level – Automatic Transmission	59
Turning off Engine Manually	60
Bleeding of Fuel System	60
First Aid Kit	61
Spare Wheel, Jack, Vehicle Tool Kit	61
Wheels, Tires	62
Changing Wheels	63
Tire Inflation Pressure	64
Fuses	65
Battery	65
Headlamp Adjustment	66
Replacing Bulbs	66
Emergency Operation of Sliding Roof	69
Unlocking of Fuel Filler Flap	69
Tow-starting and Towing the Vehicle	70
Jump starting	71
Cleaning and Care of the Vehicle	72
Rear Seat Cushion	75
Ash tray	75
Roof Rack	76
Spare Parts Service	76

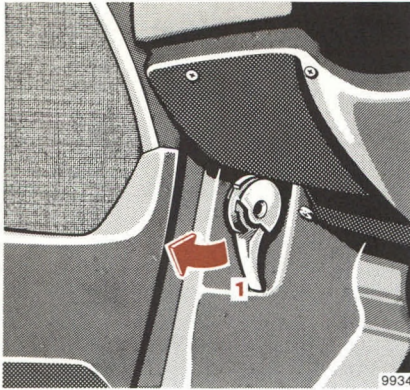

Hood

To open:

Pull hood release lever (1) under the LH side of instrument panel to unlock the hood. This will cause handle (2) to come out of radiator grill (it may be necessary to lift hood up slightly).

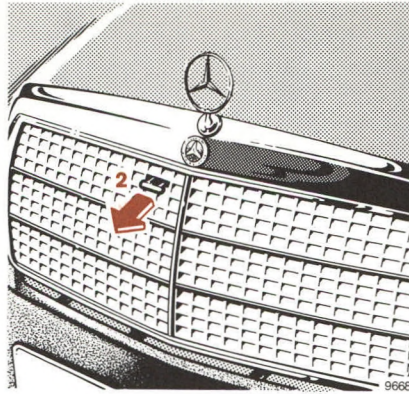

Pull handle (2) completely out of radiator grill and open hood to approximately 45° (windshield wiper arm must not be folded out).

To close:

Push hood down on left side (viewed in driving direction). Make sure that hood is securely locked.

Note:

If the hood is raised to the vertical position, a locking pawl will engage at the left hinge (viewed in driving direction).

To lower or close the hood, press down release lever on left hinge.

Warning:

Stay clear of moving parts when the hood is open and the engine is running.

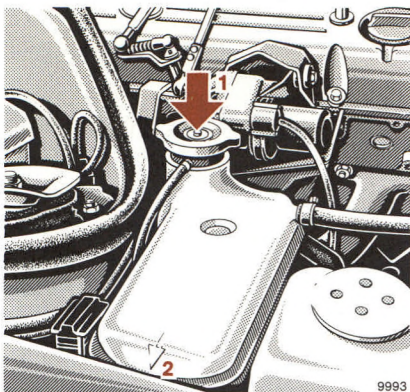

- 1 Coolant Filler
- 2 Marking for coolant level

Checking Coolant Level

The coolant level can be checked visually at the transparent coolant reservoir.

To check the coolant level, the vehicle must be parked on level ground.

The coolant level must reach:

The marking (2, arrow) on the reservoir when the engine is cold.

Approx. 1 cm/0.4 in higher when the engine is at operating temperature.

Adding Coolant

If a small amount of coolant has to be added (due to evaporation of water), plain water can be used.

If a larger quantity of coolant has to be added, a 50/50 mixture of water and anti-corrosion/antifreeze should be used.

Warning:

Do not remove pressure cap on coolant reservoir if engine temperature is above 90° C/194° F. Allow engine to cool down before removing cap. The coolant reservoir contains hot water and is under pressure.

Using a rag, turn cap to first notch to relieve excess pressure. If opened immediately, hot scalding fluid and steam will be blown out under pressure.

The drain plugs for the cooling system are located on the right-hand side of the engine block and the bottom of the radiator.

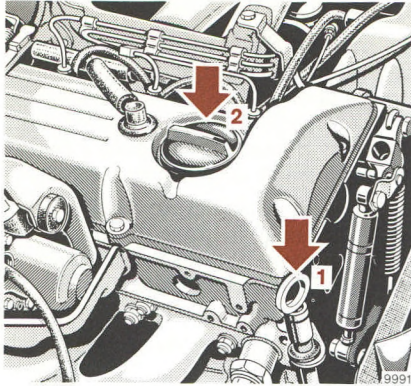

- 1 Dipstick
- 2 Oil filler cap

Engine Oil Level Check

Check engine oil level at regular intervals, after refueling, with the engine at operating temperature and shut off.

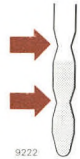

The vehicle should be parked on level ground and the oil level must be somewhere between the lower and the upper mark on dipstick (1); do not add in excess of the upper mark.

Wipe dipstick before any oil level measurement. To determine the oil level, check both sides of the dipstick. Always determine the oil level by means of the straight horizontal marking formed by the oil on one side of the dipstick.

For viscosity and capacity, see "Fuels, Coolants, Lubricants, etc." and last page.

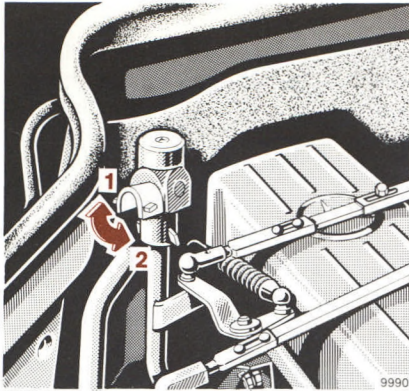

Fluid Level – Automatic Transmission

At regular intervals and prior to a long trip, check automatic transmission fluid level and engine oil level.

Check transmission fluid level with the engine idling, parking brake engaged and selector lever in position “P”. The vehicle must be parked on level ground. Prior to the check, allow engine to idle for approx. 1 to 2 minutes.

Measure fluid level with the dipstick completely inserted and the locking lever released (1).

Extreme cleanliness must be observed!

To wipe the dipstick, use a clean, lintfree cloth.

To fill the transmission with fluid, only pour it through a fine-mesh filter into the dipstick opening. Even the slightest impurity may cause operational troubles.

The fluid level in the transmission is dependent upon its temperature.

The maximum and minimum oil level marks on the dipstick are applicable references only if the transmission fluid has reached its normal operating temperature of 80° C/ 176° F.

If transmission fluid cools down to 20–30° C/68–86° F, which is the normal shop temperature range, then the maximum fluid level will be approximately 12 mm/0.5 in below the minimum mark on the dipstick. We stress this point because a fluid change is normally performed when the transmission fluid has cooled down to shop temperature.

The fluid level must not exceed the dipstick maximum mark with the fluid at operating temperature. Drain or siphon off excess fluid, if required.

Then push dipstick all the way in and swing locking lever downwards (2).

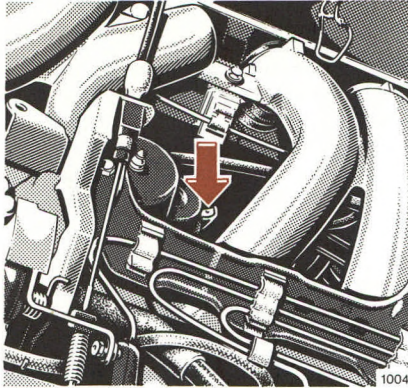

Turning off Engine Manually

If the engine continues operating in steering lock position 0, open hood and press lever marked "STOP" until the engine stops.

Bleeding of Fuel System

The fuel system is a self bleeding system. Turn the key in steering lock fully to the right and crank engine (for up to one minute maximum). Push accelerator pedal to the floor while cranking engine. Only release key after engine fires evenly.

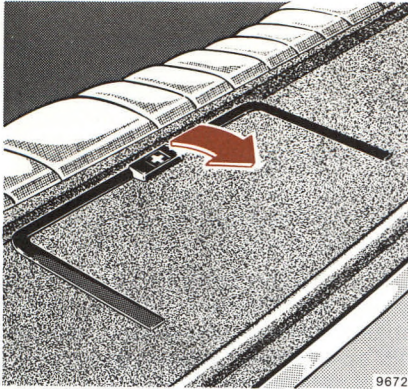

First Aid Kit

The first aid kit is stored in the hat shelf at the rear.

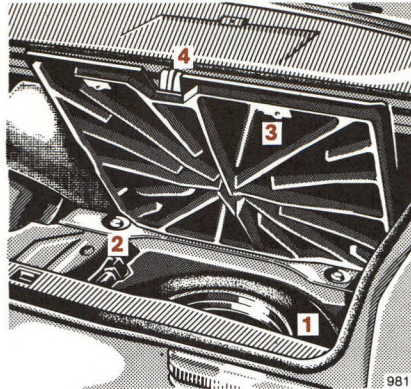

Spare Wheel, Jack, Vehicle Tool Kit

The spare wheel (1), jack (2) and tool kit are stored in a compartment below a hinged door (3) in the trunk floor.

To raise the door, roll back the floor mat and engage holding strap (4) in the trunk lid.

The hinged door can also be removed completely by raising the door to approximately 45°, lifting it slightly at the hinged side and pulling it out to the rear.

Warning:

Use the jack only to lift the vehicle during a wheel change. Never get beneath the vehicle while it is supported only by the jack. Use jack stands to work under the car.

Wheels, Tires

In case of replacement we recommend you use tires and rims of identical design, version and brand.

See any MERCEDES-BENZ service station for information on tested and recommended wheels and tires for summer and winter operation. They will also offer more advice concerning tire service and purchase

Front tires should be replaced in sets. If possible, the spare tire should be used on the rear wheels. We recommend that you break in new tires for approximately 100 km/60 miles at moderate speed.

After a wheel change, it is imperative that the wheel mounting bolts be retightened after approx. 800 km/500 miles. On new vehicles retightening is carried out in the

course of the 1st inspection. Retightening is also necessary when new wheels are fitted at a later date, e.g. when the spare wheel is used for the first time or when a new set of wheels with M + S tires is fitted.

For tire specifications, refer to "Technical Data".

Rotating wheels:

The wheels can be rotated according to the degree of tire wear while retaining the same sense of rotation. Rotating, however, should be carried out before the characteristic tire wear pattern (shoulder wear on front wheels and tread center wear on rear wheels) becomes visible at a mileage of 5000–10000 km/3000–6000 miles as otherwise the driving properties deteriorate.

Slowly leaking air (e.g. due to a nail in the tire) may cause damage to the tire such as tread separation. Regular tire pressure checks at intervals of no more than 14 days are therefore essential. For the tire pressure checks, keep in mind that hot tires show higher pressure than cold tires. See tire pressure chart on last page.

Should the tire pressure decrease constantly, check whether foreign objects have penetrated the tire or if rim or valve allow the air to leak.

Thoroughly clean the inner side of the wheels any time you rotate the wheels or wash vehicle underside.

Dented or bent rims cause tire pressure loss and damage to the tire beads. For this reason, check rims for damage at regular intervals. The rim flanges must be checked for wear before a tire is mounted. Remove burrs, if there are any.

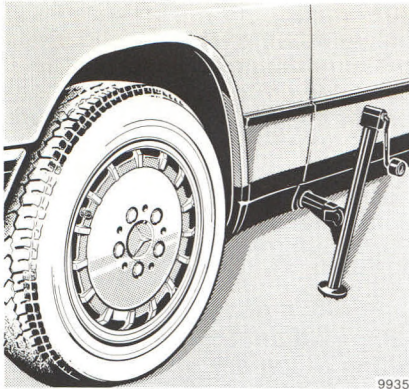

Changing Wheels

1. Set parking brake.
2. With manual transmission, shift gear shift lever to 1st or reverse gears respectively, with automatic transmission, move selector lever to position "P".
3. Prevent vehicle from rolling away by blocking wheels with wheel chocks: When changing a wheel on a hill, place chocks behind each wheel of the axle opposite to the axle to be worked on; on a level road, place one chock in front and one behind of the wheel that is diagonally opposite to the wheel being changed.
4. Using the combination wrench, loosen but do not yet remove the wheel bolts.
5. Remove protective cap from the jack support tube. (The tube openings are located directly behind the front wheel housings and in front of the rear wheel housings.)
6. Insert jack arm fully into the tube hole up to the stop. Position the jack so that it will always be vertical as seen from the side, even on inclines. Jack up the vehicle until the wheel is clear off the ground.
7. Then unscrew wheel bolts completely. Keep bolt threads protected from dirt and sand. While removing last bolt, hold wheel against axle to avoid paint damage on rim.
8. Remove wheel.
9. Screw the alignment stud, which comes with the spare tire, into the upper threaded hole of the hub prior to installing wheel.
10. Adjust the jack to allow the wheel to be slipped on without being lifted.
11. Install spare wheel (valve in bottom position) on wheel hub. Insert wheel bolts and tighten them slightly. To avoid paint damage, place wheel flat against hub and hold it there while installing first wheel bolt. Unscrew the alignment stud to install the last wheel bolt.
12. Lower car, remove jack and place cap into the jack support tube. Tighten the five bolts evenly, always skipping one, until all bolts are tight. Observe a tightening torque of 110 Nm/ 80 lb-ft.
13. Correct tire pressure.

Tire Inflation Pressure

A table (see fuel filler flap or last page) lists the tire inflation pressures specified for summer and winter tires as well as for the varying operating conditions.

Important!

Tire pressure differs by approx. 0.1 bar/1.5 psi per 10° C/18° F of air temperature change. Keep this in mind when checking tire pressure inside a garage – especially in the winter.

Example:

Room temperature = approx.
+ 20° C/+ 68° F

Ambient temperature = approx.
0° C/+ 32° F

Adjusted air pressure = specified
air pressure + 0.2 bar/3 psi.

Tire pressures listed for light loads are minimum values offering high driving comfort. Increased inflation pressures for heavy loads produce favorable handling characteristics with lighter loads and are perfectly permissible. The ride of the vehicle, however, will become somewhat harder.

Tire temperature and pressure increase with the vehicle speed. Tire pressure should therefore only be corrected on cold tires. Correct tire pressure in hot tires only if pressure has dropped below the data listed in the table and the respective operating conditions are taken into consideration.

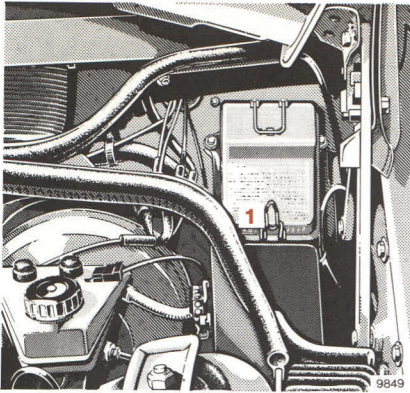

Fuses

The fuse box is located in the engine compartment.

All electrical circuits are numbered and protected by a fuse. The numbers of the circuits and all power consumers in each circuit are listed inside the fuse box cover.

To exchange a fuse, remove clamp (1) and remove fuse box cover.

Before replacing a blown fuse, determine the cause of the short circuit.

Spare fuses are furnished inside the fuse box. Observe amperage and color of fuse.

Always use a new fuse for replacement. Never attempt to fix or bridge a blown fuse.

After replacing a fuse, replace fuse box cover and secure with clamp (1).

Battery

Check fluid level in each cell approximately every 4 weeks, and more frequently during the summer and in hot climates.

Refill battery only with distilled water. Do not use metal funnels nor push through the overfill-protection diaphragms in filler holes.

The battery is completely filled when the water stops draining through the overfill-protection diaphragm.

To check the battery charge with a hydrometer, push its tip through the overfill-protection diaphragm and take the electrolyte sample.

Coat battery terminal clamps with acidproof grease. Keep battery clean and dry.

Only tow vehicle with the battery connected.

Only charge battery with a battery charger when it is disconnected from the vehicle electrical circuit.

Caution:

While the engine is running the battery terminal clamps must not be loosened or detached as otherwise the alternator and other electronic units would be damaged.

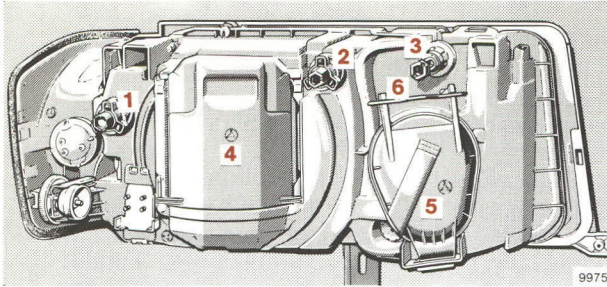

9975

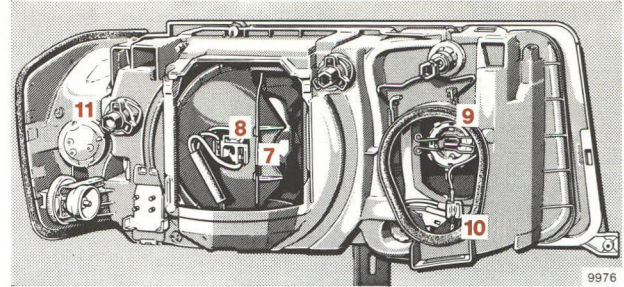

9976

Headlamp Adjustment

Correct headlamp adjustment is extremely important. Check and readjust headlamps at regular intervals and when a lamp has been replaced.

Replacing Bulbs

Only handle new bulbs for headlamps and tail lamps with tissue paper or similar.

Install only 12 volt bulb with the specified watt rating.

Headlamp Assembly

- 1 Headlamp horizontal adjusting screw
- 2 Headlamp vertical adjusting screw
- 3 Fog lamp adjusting screw
- 4 Headlamp cover
- 5 Fog lamp cover

- 6 Fog lamp cover clamp
- 7 Headlamp cover clamp
- 8 Headlamp electrical connector
- 9 Fog lamp
- 10 Fog lamp electrical connector
- 11 Turn signal, parking, side marker and standing lamp bulb

Replacing bulbs:

Bulb for turn signal, parking, side marker and standing lamp (21/5 W/32/3 cp):

Turn bulb socket (11) with lamp bulb to the left and pull out socket.

Push lamp bulb into socket and turn to the left and pull out bulb.

Sealed Beam/Halogen headlamp:

Pull cover (4) up to release it from bracket.

Disconnect plug (8) and disengage clamp (7).

Take out sealed beam together with retaining frame towards the front. Press off frame from sealed beam.

Fog lamp bulb (H 3):

Disengage clamp (6) and remove cover (5). Disconnect plug (10), disengage retaining clip and remove bulb (9).

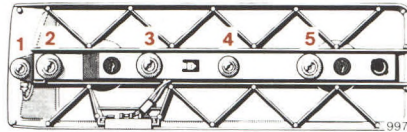
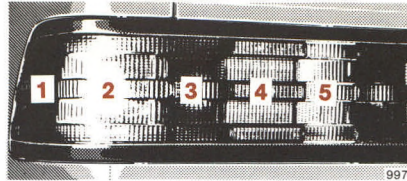

Tail Lamp Assemblies

- 1 Side marker lamp (10 W/6 cp)
- 2 Turn signal lamp (21 W/32 cp)
- 3 Stop lamp (21 W/32 cp)
- 4 Tail, parking and standing lamp (10 W/6 cp)
- 5 Backup lamp (21 W/32 cp)

Turn both locks in the trunk to the left as far as the stop and detach lamp bracket. To replace the bulbs, depress, turn to the left and remove.

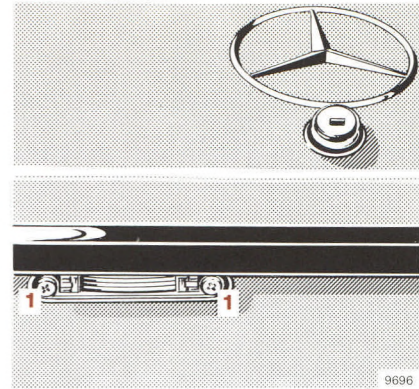

License Plate Lamps

(5 W festoon lamp)

Loosen both the securing screws (1) and take out lamp.

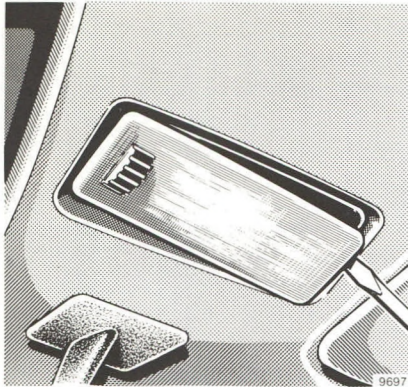

Interior Lamps
(10 W festoon lamp)

To replace the bulb, lift off front lamp at RH side, pull it out and open reflector.

The same applies to the removal of the rear lamp.

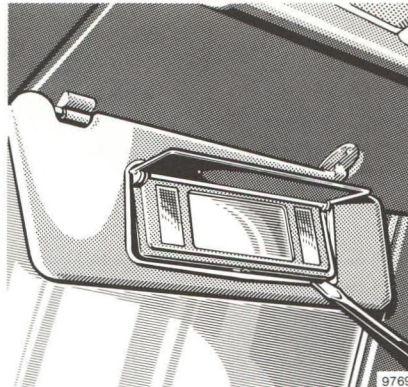

Sun Visor Lamps
(5 W festoon lamp)

To replace a bulb, pry off the cover by inserting a screwdriver in the left and right slots located on the lower edge.

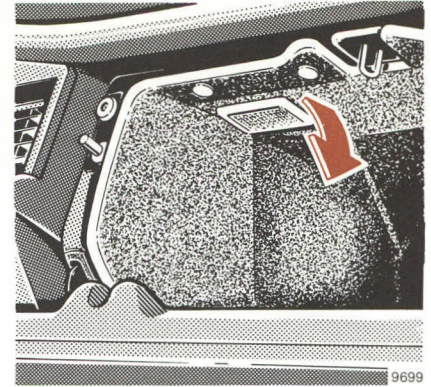

Glove Compartment Lamp
(5 W festoon lamp)

To replace the bulb, pull out lamp.

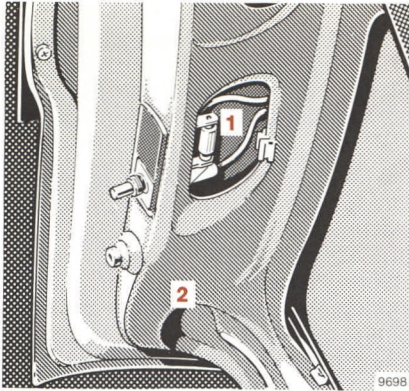

Trunk Lamp (10 W festoon lamp)

The bulb (1) is easily accessible when the trunk lid (2) is opened.

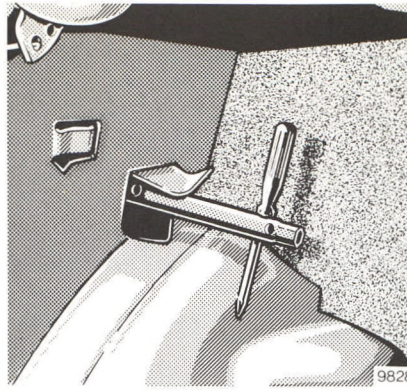

Emergency Operation of Sliding Roof

The sliding roof can be opened or closed manually should an electrical malfunction occur.

Remove small access plug in left side-panel of trunk. Insert socket wrench (from tool kit) through opening in panel and place on the hex-drive on the electric motor. Turn socket wrench as desired to open or close roof.

Turning socket clockwise, closes roof.

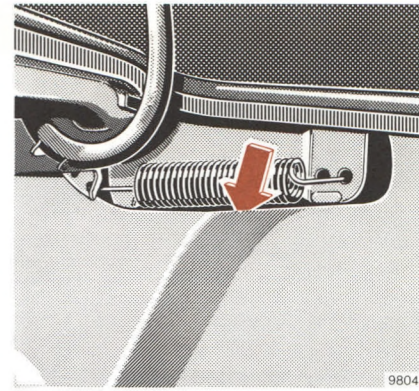

Unlocking of Fuel Filler Flap

If the central locking system does not release the fuel filler flap automatically, pull down right trunk panel slightly and pull back the connecting rod between the vacuum element and door tab.

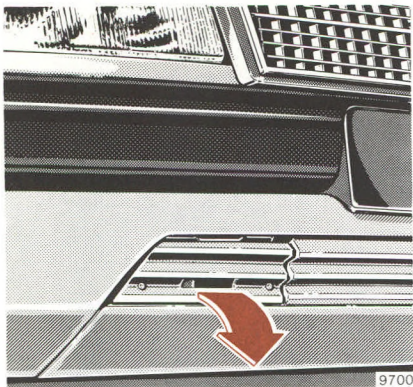

Tow-starting and Towing the Vehicle

The rear towing eye is welded from below to the right side of the spare tire compartment. The front towing eye is located behind the flap in the front bumper panel (arrow).

Flap removal: Insert finger in the opening of the flap, pull the flap out slightly and downward to remove.

To install the flap, engage the flap at the top and press in the bottom securely.

Engage hook of towing bar from the right side of the towing eye. This will ensure adequate clearance between the towing bar and the bumper panel opening during turns.

Only tow-start vehicle with the battery connected and the key in steering lock position 2.

Warning:

When the engine is not running, both the service brake and the steering are without power assistance. Under these circumstances, a much greater effort is necessary to steer or stop the vehicle.

Tow-starting a Vehicle with Automatic Transmission

Shift selector lever to position "N". Turn key in steering lock to position 2 and have vehicle towed.

To crank the engine, shift selector lever to "2". Touch the accelerator only when the engine starts firing. As soon as the engine has started, immediately return selector lever to "N".

It is important to allow the engine to idle for at least 1 minute before starting off because the preglowing process starts when the key is in steering lock position 2 and is not immediately disrupted after the engine has been tow-started. During this time the preglowing process is cut out automatically.

If the engine has not fired after a few seconds, shift the selector lever to "N" to protect the transmission from damage.

For a new starting attempt, tow-start the vehicle for some time again with the selector lever in position "N" and repeat the starting procedure.

The same method can be used to start the engine in emergencies when rolling downhill.

Towing a Vehicle with Automatic Transmission

The vehicle may be towed with all of the wheels on the ground and the selector lever in position "N" for distances up to 120 km/75 miles and at a speed not to exceed 50 km/h/30 mph.

To positively avoid a possibility of damage to the transmission, however, we recommend to disconnect the drive shaft at the rear axle drive flange on any towing beyond a short tow to a nearby garage.

Jump Starting

If the battery is discharged the engine can be started with jumper cables (minimum cable cross section is 35 mm²) and the (12 V) battery of another vehicle. Proceed as follows:

1. Turn key to steering lock position 0.
2. First connect jumper cables to the positive battery terminals and then to the negative terminals.
3. Start and run engine of jumper vehicle at high idle.
4. Start engine of the disabled vehicle in the usual manner.
5. After the engine has started, first remove jumper cables from the negative battery terminals and then from the positive terminals.

Instructions:

A discharged battery can freeze at approx. - 10° C/+14° F. In all cases it must be thawed out before jumper cables are used.

Never lean over batteries while jump starting.

Warning

Battery fluid contains sulfuric acid. Do not allow this fluid to come in contact with eyes, skin, or clothing. In case it does, immediately flush affected area with water.

A battery will also produce hydrogen gas, which is flammable and explosive. Keep flames or sparks away from battery, i. e. improper connection of jumper cables, cigarette smoking, etc..

Cleaning and Care of the Vehicle

In operation, your vehicle is subjected to a great amount of varying external influences which, if gone unchecked, can attack the paintwork as well as the underbody and cause lasting damage.

Such damage is caused not only by extreme and varying climatic conditions, but also by air pollution, road salt, tar, gravel and stone chipping. Grease and oil, fuel, coolant, brake fluid, bird droppings, tree resins, etc. should immediately be removed to avoid paint damage. Frequent washing, however, reduces and/or eliminates the aggressiveness and potency of the above adverse influences.

More frequent washings are necessary to deal with unfavorable conditions; for example, near the ocean, in industrial areas (smoke, exhaust emissions), or during winter operation.

You should check your vehicle from time to time for stone chipping or other damage. Any damage should be repaired as soon as possible to prevent the start of corrosion.

In doing so, do not neglect the underside of the car. A prerequisite for a thorough check is a washing of the underbody followed by a thorough inspection. Damaged areas need to be re-undercoated.

Your vehicle has been treated at the factory with a wax-base rustproofing in the body cavities which will last for the lifetime of the vehicle. Post-production treatment is neither necessary nor recommended by MERCEDES-BENZ because of the possibility of incompatibility between materials used in the production process and others applied later.

After every engine cleaning you should have the engine compartment re-rustproofed. Before rustproofing, all control linkage bush-

ings have to be lubricated with hydraulic oil (check with your local MERCEDES-BENZ dealership for recommended brands).

We have selected car-care products and compiled recommendations which are specially matched to our vehicles and which always reflect the newest in technological standing. You can obtain MB car-care products at every MERCEDES-BENZ service station.

Scratches, corrosive deposits, corrosion or damage due to negligent or incorrect care cannot always be removed with the car-care products recommended here. In such cases it is best to seek aid at your MERCEDES-BENZ service station.

The following topics deal with the cleaning and care of your vehicle and give important "how-to" information as well as references to recommended MB car-care products.

Car Washing

Before washing your vehicle, remove insect residues. The car should not be washed in the sun.

Use only a mild car wash detergent, such as MB auto shampoo.

Thoroughly spray the car with a diffused jet of water. Direct only a very weak spray towards the ventilation intake. Use plenty of water and rinse the sponge and chamois frequently. Rinse with clear water and thoroughly wipe dry with a chamois.

If the vehicle has been run through an automatic car wash – in particular one of the older installations – rewipe the recessed sections provided in the tail lamps (for improved prevention of soiling) if necessary. No solvents (fuels, thinners etc.) must be used.

In the winter, thoroughly remove all traces of road salt as soon as possible.

When washing the underbody, do not forget to clean the inner sides of the wheels.

Tar Stains

Quickly remove tar stains before they dry and become more difficult to remove.

Window Cleaning

Use a window cleaning solution on very dirty or oil-stained windows. Clean windshield wiper blades with a clean cloth and detergent solution. Replace blades at least once or twice a year.

Plastic Parts, Headliner, Rubber Parts and MB-Tex Upholstery Covers

Do not use oil or wax on these parts.

Seat Belts

The webbing must not be treated with chemical cleaning agents. Use only clear, lukewarm water and soap. Do not dry the webbing at temperatures above 80° C/176° F or in direct sunlight. Never bleach or redye the webbing.

Steering Wheel, Gear Shift Lever and Instrument Cluster

Use a gentle dish-washing detergent or mild detergent for delicate fabrics as a washing solution. Wipe with a cloth moistened in lukewarm solution. Do not use scouring agents.

Upholstery

Leather: Wipe leather upholstery with a damp cloth and dry thoroughly. Exercise particular care when cleaning perforated leather as its underside should not become wet.

Velours: Pressure marks resulting from dampness and heat may appear to be stains. Such marks can be removed by wiping with a moistened brush, ironing with a wet cloth or by treating with a dry shampoo. Do not sit on damp upholstery. Quick drying is achieved by applying hot air – for example, by using a hair dryer. If in doubt, please consult your MERCEDES-BENZ service station.

Paintwork

Do not apply wax if your car is parked in the sun or if the hood is still hot.

For maximum protection, the paintwork should be waxed approximately once every three months. Use the appropriate MERCEDES-BENZ Touch-Up Stick for quick and provisional repairs of minor paint damage.

Light Alloy Wheels

If possible, clean wheels once a week with lukewarm water and autoshampoo. Use an ample supply of water.

To remove stubborn marks, use polish or paint cleaner and apply with buffing cloth or a soft cloth.

Ornamental Moldings

For regular cleaning and care of very dirty chrome-plated parts, use a chrome cleaner.

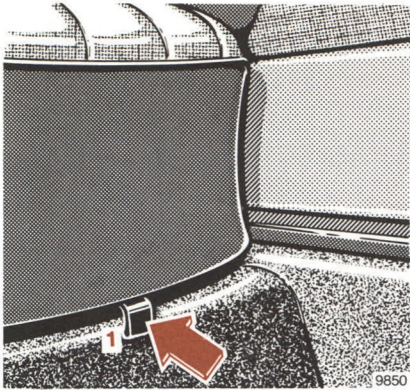

Rear Seat Cushion

Removal: Push in locking tabs (1) (on left and right side) and carefully pull up seat at the front (do this carefully to prevent injury!).

Installation: Push rear edge of seat cushion under the backrest and push front edge of seat cushion down until it locks in.

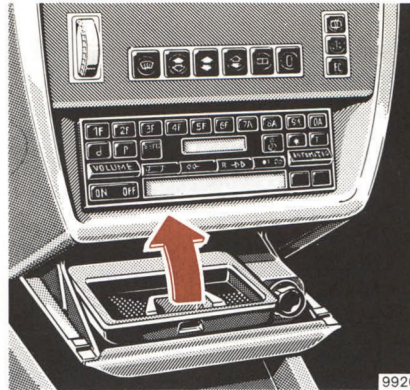

Ash tray

Removal, front:

Open ash tray against stop. Place hand under tray. Pull frame up and out.

Removal, rear:

Open ash tray against stop. Press down center spring and remove ash tray.

Installation:

Engage ash tray bottom into frame, push down release spring and close ash tray.



Roof Rack

We recommend the use of drip rail mounted ski and roof racks. These racks do not require additional supports (suction cups or legs).

Use only our approved roof rack in order to avoid damage to the vehicle.

Mount supports only between markings on border of roof which are visible when doors are opened.

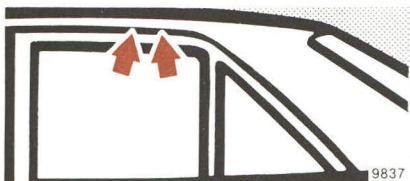

Spare Parts Service

All MERCEDES-BENZ service stations maintain a stock of original spare parts required for maintenance and repair work. In addition, strategically located parts distribution centers provide quick and reliable parts service.

More than 200 000 different spare parts, even for rather old vehicle models, are available.

MERCEDES-BENZ original spare parts are subjected to most severe quality inspections. Each part has been specifically developed, manufactured or selected for and adapted to MERCEDES-BENZ vehicles. Therefore, MERCEDES-BENZ original spare parts should be installed.

Technical Data Fuels, Coolants, Lubricants etc.

Identification Plates	78
Vehicle Data Cards	79
Warranty Coverage	79
Technical Data	80
Fuels, Coolants, Lubricants, etc.	82
Capacities	82
Engine Oils	85
Brake Fluid	85
Diesel Fuels	86
Coolants	87
Consumer Information	88

Identification Plates

When ordering spare parts, please quote chassis and engine numbers.

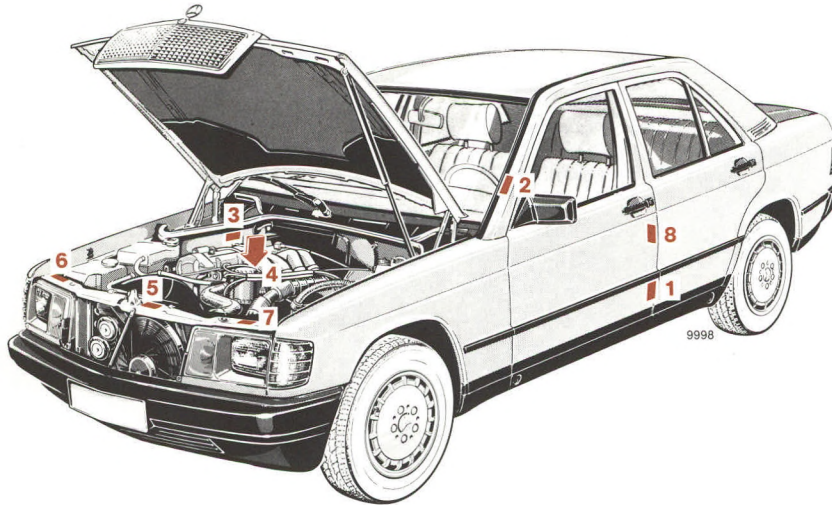

- 1 Certification Tag
(left door pillar)
- 2 Identification Tag
(left window post)
- 3 Chassis No.
- 4 Engine No.
- 5 Body No. and Paintwork No.
- 6 Information Tag
California version
Vacuum line routing
for emission control system
- 7 Emission Control Tag
- 8 Emission Control Tag
Catalyst Information

Vehicle Data Cards

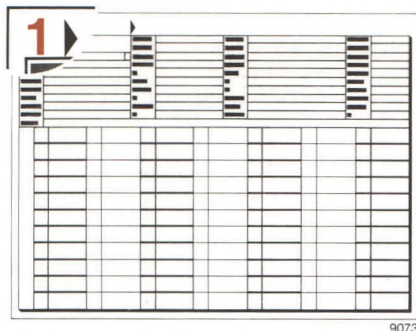

The vehicle data cards bear all the important data relating to your vehicle.

Data card No. 1 bears the key number and should never be left in the vehicle. Submit this card to your MERCEDES-BENZ service station to request a replacement key in case of loss.

Data card No. 2 bears no key data and is kept in the Maintenance Booklet. Presenting this card to the service station will facilitate the processing of the order.

Warranty Coverage

Your car is covered under the terms of the “warranties” printed in the Owner’s Service and Warranty Policy Booklet and your dealer will exchange or repair any defective parts in accordance with the terms of the following warranties:

1. New vehicle limited warranty
2. Emission systems warranty
3. Emission performance warranty
4. California emission control systems warranty (state of California only unless purchased optionally for diesel models)

Loss of Owner’s Service and Warranty Policy

Should you lose your Owner’s Service and Warranty Policy Booklet, have your local MB dealer arrange for a replacement. It will be mailed to you.

Technical Data

Type	190 D 2.2 (201 122) ¹
------	----------------------------------

Engine

Engine type	601
Work cycle	Diesel four stroke
No. of cylinders	4
Bore	87.0 mm/3.43 in
Stroke	92.4 mm/3.64 in
Total piston displacement	2197 cm ³ /134.1 in ³
Compression ratio	22
Output acc. to SAE	54 kW/4200 rpm/ 72 net-bhp/4200 rpm
Injection order	1-3-4-2
Flat Drive Belts	2120 mm

¹ The quoted data apply only to the standard vehicle. See a MERCEDES-BENZ service station for the corresponding data of all special bodies and special equipment.

Transmission

Design	Manual five-speed transmission
Optional extra	Automatic four-speed torque-converter transmission

Steering System

Design	Power steering
--------	----------------

Rims-Tires

Rims (forged light alloy rims)	5 J × 14 H 2
Summer tires: Radial-ply tires	175/70 R 14 82 S 175/70 R 14 84 S
Winter tires: Radial-ply tires	175/70 R 14 82 T M + S 175/70 R 14 84 T M + S

Technical Data

Electrical System

Alternator	14 V/55 A
Starter motor	12 V/2.2 kW
Battery	12 V/72 Ah

Weights	See certification tag
----------------	-----------------------

Main Dimensions

Overall vehicle length	4445 mm/175.0 in
Overall vehicle width	1678 mm/ 66.1 in
Overall height	1383 mm/ 54.4 in
Wheel base	2665 mm/104.9 in
Track, front	1428 mm/ 56.2 in
Track, rear	1415 mm/ 55.7 in

Fuels Coolants Lubricants etc. Capacities

Vehicle components and their respective lubricants must match. Therefore use only brands tested and recommended by us. Enquire at your MERCEDES-BENZ service station.

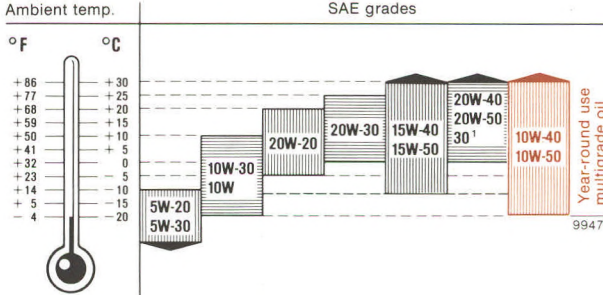
	Capacity	Fuels, coolants, lubricants, etc.
Engine with oil filter	6.0 l/6.3 US qt	<p data-bbox="843 449 1151 471">Recommended engine oils</p>  <p data-bbox="843 837 1290 874">¹ SAE 40 may be used if ambient temperatures constantly exceed + 30° C/+ 86° F.</p>

	Capacity	Fuels, coolants, lubricants, etc.
Manual transmission	1.5 l/1.6 US qt	Automatic transmission fluid for manual transmission ¹
Automatic transmission	Initial fill: 6.6 l/7.0 US qt Fluid change: 5.5 l/5.8 US qt	Automatic transmission fluid for automatic transmission ¹
Rear axle	0.7l/0.7 US qt	Hypoid gear oil SAE 90, 85 W 90 ¹
Power steering	0.6 l/0.6 US qt	Automatic transmission fluid for power steering ¹
Accelerator control linkage		Hydraulic fluid ¹
Front wheel hubs	50 g each, approx. 1.8 oz. each approx.	High temperature roller bearing grease

¹ For recommendations on recommended brands, see your nearest MERCEDES-BENZ service station.

	Capacity	Fuels, coolants, lubricants, etc.
Battery terminals		Bosch special grease
Brake and (with manual transmission) clutch reservoir	approx. 0.5 l/0.5 US pt	Brake fluid ¹
Windshield washer system	approx. 3.0 l/3.2 US qt	Windshield washer solvent
Fuel tank including a reserve of	approx. 55 l/14.5 US gal approx. 7.5 l/2.0 US gal	Diesel fuels acc. to ASTM D 975 grades 1 and 2 as well as VV-F-800 a grades 1 and 2
Cooling system	approx. 8.5 l/9.0 US qt	Coolant ¹

¹ For recommendations on recommended brands, see your nearest MERCEDES-BENZ service station.

Engine Oils

Engine oils are specifically tested for their suitability in our engines. Therefore, use only engine oils recommended by us. Information on recommended brands is available at any MERCEDES-BENZ service station.

On a new vehicle, the engine is filled with an initial operation oil in the factory. This oil is specially developed for the specific operating conditions during the first 1300–1600 km/800–1000 miles.

A recommended engine oil may be used for topping up if the oil level drops below the dipstick minimum mark prior to the first service 1300–1600 km/800–1000 miles.

Brake Fluid

During the course of the operation of the vehicle, the boiling point of the brake fluid is continuously being reduced through the absorption of moisture from the atmosphere. Under extremely hard operating conditions, this moisture content can lead to the formation of vapor in the system, thus reducing the system's efficiency. The brake fluid must therefore be replaced annually, preferably in the spring. It is recommended to use only brake fluid approved by MERCEDES-BENZ.

Your MERCEDES-BENZ dealer will provide you with additional information.

Diesel Fuels

Use only commercially available vehicular diesel fuels No. 2 or No. 1 (ASTM D 975 No. 2-D or No. 1-D).

Change engine oil in compliance with section "Engine Oil Change and Oil Filter Service" if diesel fuels are used whose sulphur content exceeds 0.5% by weight. Marine diesel fuel, heating oil or the like must not be used.

At very low temperatures the fluidity of No. 2-D diesel fuel may become insufficient due to paraffin separation.

To avoid malfunctions, No. 2-D diesel fuel of a lowered cloud point is marketed during the cold season.

At temperatures below 0° C/ + 32° F use winterized or No. 1 diesel fuel only. If not available, a certain quantity of kerosene may be added. Mixing only to be done within the cars' fuel tank. Kerosene has to be filled in before the diesel fuel.

Engine power may drop according to the proportion of kerosene. For this reason, keep percentage of kerosene added to the minimum necessitated by the ambient temperature.

The following table can be used as a reference, if adding of kerosene becomes necessary. The mixing ratios shown refer to the total mixture.

Even in extreme climatic conditions, the maximum mixture ratio should not exceed 50%.

Adding of kerosene to No. 1-D diesel fuel is not recommended even at low temperatures.

Warning

Always follow basic safety rules when working with any combustible material. Do not fill the fuel tank or mix diesel fuel and kerosene when smoking, near an open flame or while the vehicle's engine is running. An explosion or fire can result.

Ambient temperature	No. 2 Diesel Fuel %	Kerosene %
0° C to -10° C/ +32° F to +14° F	70	30
below -10° C/ +14° F	50	50

Coolants

The coolant is a mixture of water and anti-corrosion/antifreeze. In production, the cooling system is filled with an anti-corrosion/antifreeze-water mixture offering protection to approx. $-30^{\circ}\text{C}/-22^{\circ}\text{F}$. The red mark on the temperature gauge in the instrument cluster is matched to this anti-corrosion/antifreeze-water mixture (approx. boiling point $125^{\circ}\text{C}/257^{\circ}\text{F}$). The protection against corrosion is also ensured by this mixture making it unnecessary to add a corrosion inhibitor.

The coolant remains in the cooling system all year long and must be renewed after 3 years at the latest.

If coolant is lost, replace missing quantity with water (potable water quality) plus anti-corrosion/antifreeze of a recommended brand.

For reasons of corrosion inhibition the minimum proportion of anti-corrosion/antifreeze must be 34%, which gives anti-corrosion/antifreeze protection down to $-20^{\circ}\text{C}/-4^{\circ}\text{F}$.

If anti-corrosion/antifreeze is temporarily not available, add a corro-

sion inhibitor to the cooling water to ensure proper protection against corrosion. To treat the cooling water, do not use more than 1% ($10\text{ cm}^3/\text{l}$) of a recommended corrosion inhibitor.

Without anti-corrosion/antifreeze in the cooling system, the water already starts boiling at approx. $118^{\circ}\text{C}/224^{\circ}\text{F}$, which means that the pointer of the temperature gauge in the instrument cluster may still be below the red mark.

Driving the vehicle without anti-corrosion/antifreeze should be done only in an emergency situation. Add anti-corrosion/antifreeze as soon as possible.

Anti-corrosion/antifreeze

Your vehicle contains a number of aluminium parts. The use of aluminium components in motor vehicle engines necessitates that anti-corrosion/antifreeze/coolant used in such engines be specifically formulated to protect the aluminium parts. (Failure to use such anti-corrosion/antifreeze/coolant may result in a significantly shortened service life.)

While there may be a number of anti-corrosion/antifreeze/coolants available which will provide the requisite protection, all such products have not been tested for MERCEDES-BENZ vehicles. The following product, however, is recommended for use in your car: MERCEDES-BENZ Anti-Freeze and Summer Coolant.

Prior to the onset of the cold season, check the coolant for sufficient protection to prevent freezing. Repeat this check during the cold spell. Regular testing of the anti-corrosion/antifreeze concentration is carried out only at each MERCEDES-BENZ maintenance service.

Protection up to	Anti-corrosion/antifreeze
-20°C -4°F }	3.00 l/3.2 US qt
-30°C -22°F }	3.75l/4.0 US qt
-40°C -40°F }	4.50 l/4.8 US qt

Consumer Information

This has been prepared as required of all manufacturers of passenger cars under Title 49, Code of U. S. Federal Regulations, Part 575 pursuant to the "National Traffic and Motor Vehicle Safety Act of 1966".

Uniform Tire Quality Grading

Relevant tire grade information on tire flanks.

All passenger car tires must conform to federal safety requirements in addition to these grades.

Traction "A", "B", "C"

The traction grades, from highest to lowest, are "A", "B" and "C" and they represent the tire's ability to stop on wet pavement as measured under controlled conditions on specified government test surfaces of asphalt and concrete. A tire marked "C" may have poor traction performance.

Warning: The traction grade assigned to this tire is based on braking (straightahead) traction tests and does not include cornering (turning) traction.

Temperature "A", "B", "C"
The temperature grades of "A" (the

highest). "B" and "C" representing the tire's resistance to the generation of heat and its ability to dissipate heat when tested under controlled conditions on a specified indoor laboratory test wheel. Sustained high temperature can cause the material of the tire to degenerate and reduce tire life, and excessive temperature can lead to sudden tire failure. The grade "C" corresponds to a level of performance which all passenger car tires must meet under the Federal Motor Vehicle Safety Standard No. 109. Grades "B" and "A" represent higher levels of performance on the laboratory test wheel than the minimum required by law. Warning: The temperature grade for this tire is established for a tire that is properly inflated and not overloaded. Excessive speed, underinflation, or excessive loading, either separately or in combination, can cause heat build-up and possible tire failure.

Vehicle Stopping Distance

This figure indicates braking performance that can be met or exceeded by the vehicles to which it applies, under different conditions of loading and with partial failures of the braking system. The information presented represents results obtainable by skilled drivers under controlled road and vehicle conditions, and the information may not be correct under other conditions.

Description of the vehicles to which this table applies: **190 D 2.2**

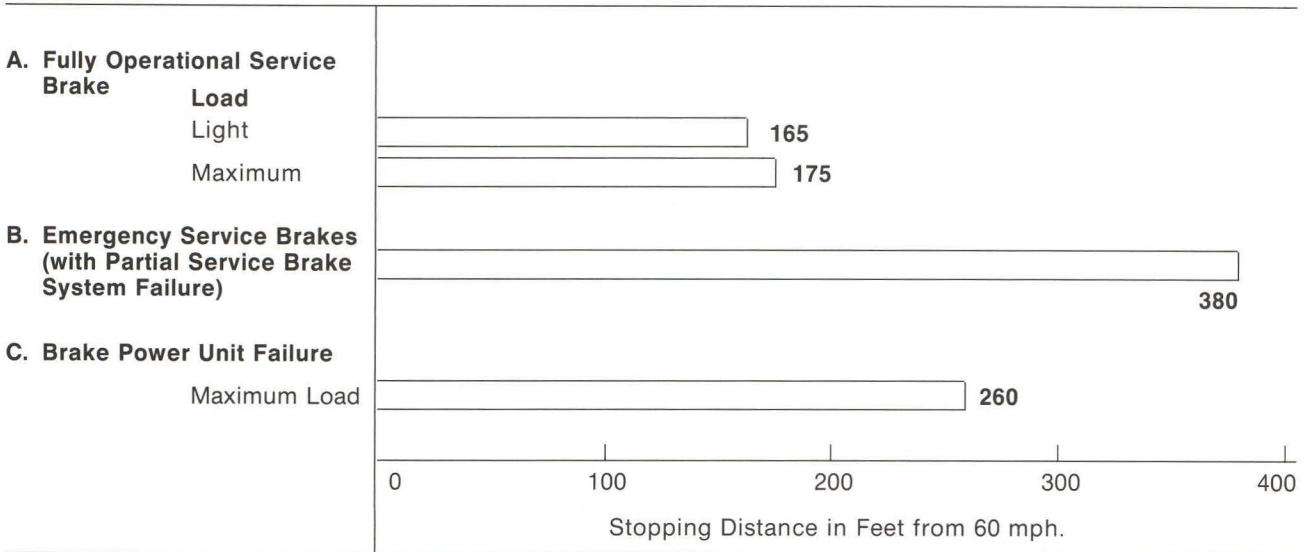



Adding coolant 57
Adjustment of driver's seat and front passenger's seat 27
Anti-corrosion/antifreeze 87
Arm rest 29
Ash tray 75
Automatic antenna 46

Battery 65
Bleeding of fuel system 60
Body No. 78
Brake fluid 52, 85
Brake pad wear indicator lamp 52

Capacities 82
Central lock system 26
Certification tag 78
Changing wheels 63

Charge indicator lamp 52
Chassis No. 78
Checking coolant level 57
Cleaning and care of the vehicle 72
Combination switch 35
Consumer information 88
Coolants 87
Coolant temperature gauge 52
Cruise control 51

Diesel fuels 86

Emergency operation of sliding roof 69
Emission control 53
Emission control tag 78
Engine No. 78

Engine oils 85
Engine oil and filter change 15
Engine oil consumption 53
Engine oil level check 58
Exterior mirrors 36

First aid kit 61
Flat key 24
Fluid level – automatic transmission 59
Fuels, coolants, lubricants, etc. 82
Fuel reserve warning lamp 52
Fuses 65

Headlamp adjustment 66
Heated seats 30
High altitude corrector device 53
Hints for driving 13
Hood 56

Identification plates 78	Paintwork No. 78	Technical data 80
Information tag	Parking brake 48	Tempmatic climate control system 18
California version 78	Power windows 40	The first 1500 km/1000 miles 6
Inside rear view mirror 36	Radio 41	Tires 62
Instruments and controls 8	Rear seat cushion 75	Tire chains 54
Instrument cluster 10	Rear window defroster 38	Tire inflation pressure 64
Interior lamps 37	Replacing bulbs 66	Tow-starting and towing the vehicle 70
Jack 61	Roof rack 76	Traveling abroad 53
Jump starting 71	Safety head restraints 28	Turning off engine manually 60
Lighter 39	Seat belts 31	Unlocking of fuel filler flap 69
Lighting switch 34	Service literature 94	Vehicle data cards 79
Locking and unlocking of doors 25	Shelf below rear window 40	Vehicle tool kit 61
Maintenance system 15	Sliding roof 39	Warranty coverage 79
Master key 24	Spare parts service 76	Wheels 62
Obtaining replacement keys 24	Spare wheel 61	Winter driving 54
Oil pressure gauge 52	Starting and shifting gears 48	
Opening the doors 25	Starting and turning off the engine 12	
Orthopedic seat backrest 28	Steering lock 33	
	Sun visors 37	
	Supplementary key 24	

Service Literature

Customers who are interested in ordering service literature for their vehicles are advised to contact our subsidiaries in the U.S. or Canada at the following addresses, respectively

for U.S.A: Mercedes-Benz of N.A. Inc.
One Mercedes Drive
P.O. Box 350
Montvale, New Jersey 07645
Att: Technical Publications
Tel.: (201) 573-0600

for Canada: Mercedes-Benz of Canada
849 Eglinton Ave., East
Toronto 17, Ont., Canada
Att: Service Department
Tel.: 416-425-3550

The above companies will be happy to handle any such requests from customers.

We consider this to be the best way in obtaining accurate information for your vehicle.



Check Regularly and Before a Long Trip

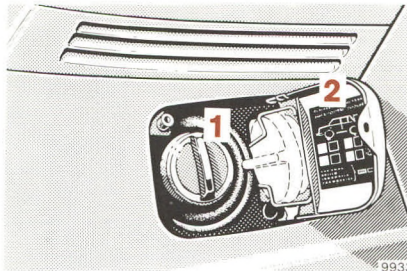
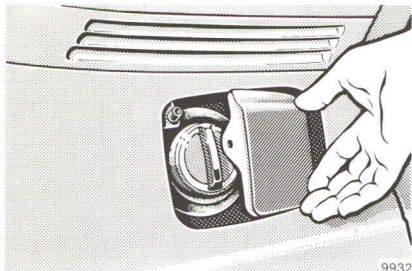

1 Fuel Supply: Turn fuel filler cap to the left and hold on to it until possible pressure in tank has been released.

2 Tire Pressure: Check at least every two weeks. For details see page 64.

3 Battery: Add only distilled water, see page 65.

4 Fluid Level in Automatic Transmission

5 Coolant level: See page 57.

6 Windshield Washer System: See page 84.

7 Engine Oil Level

8 Brake Fluid: See pages 52, 84 and 85.

Vehicle Lighting: Check function and cleanliness. For replacement of light bulbs, see pages 66 and 67.

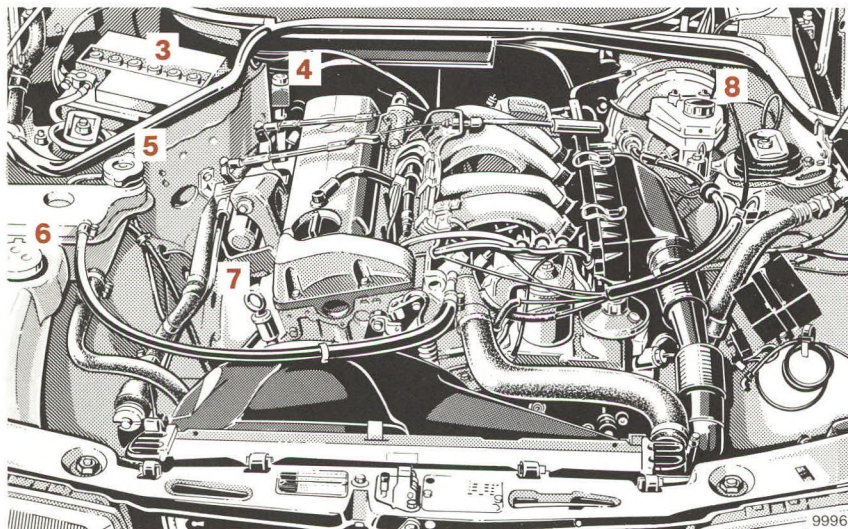

What You Should Know at the Gas Station

- **Fuel:** Diesel fuels acc. to ASTM D 975, grades 1 and 2 as well as VV-F-800 a grades .1 and 2. Fuel tank capacity approx. 55 l/14.5 US gal. This includes approx. 7.5 l/2.0 US gal reserve. Only fill fuel until the discharge nozzle unit cuts out – do not overfill.
- **Engine Oil:** Engine oil level check see page 58. Quantily differential between upper and lower dipstick marking level: 1.5 l/1.6 US qt. Year-round multigrade oils 10 W-40, 10 W-50. For further information, refer to page 82.
- **Automatic Transmission:** Automatic transmission fluid for automatic transmission. For level checks and replenishment, refer to page 59.
- **Coolant:** For normal replenishment, use water (potable water quality). For further information (e.g. anti-corrosion/anti-freeze), refer to page 87.
- **Bulbs:** High and low beams: Sealed beam/ Halogen, tail, parking and standing lamps 10 W/ 6 cp, turn signal, standing, side marker and parking lamps, front 21/5 W/32/3 cp, turn signal lamps, rear 21 W/32 cp, stop lamps 21 W/32 cp, license plate lamps 5 W festoon lamp.

- **Tire Pressure:** Cold tires:

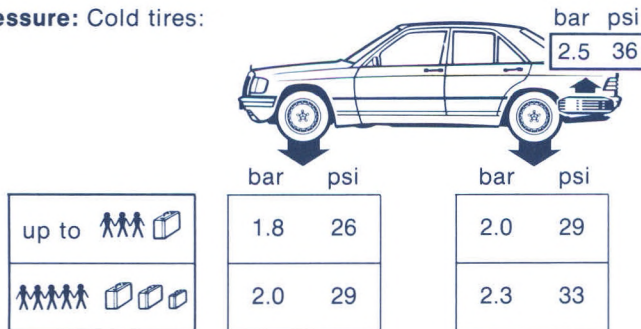

Warm tires:

Pressure may rise by up to +0.3 bar/+4 psi.

Never release any air from a warm tire to off-set this pressure increase.

Daimler-Benz AG
Stuttgart-Untertuerkheim
Zentralkundendienst



Mercedes-Benz
service

1-100-100

