

Owner's
Manual

300 TD-
TURBO DIESEL

Mercedes-Benz



1982

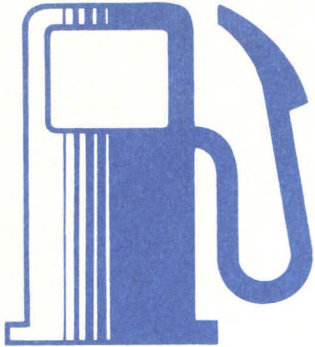

Drive Sensibly-Save Fuel

Fuel consumption depends to a great extent on driving habits and operating conditions.

In order to save fuel you should:

- ensure that tire pressures are correct
- not carry unnecessary loads
- remove ski racks or roof-mounted luggage racks when not in use
- not warm up your engine at idle and with the vehicle at standstill
- avoid frequent acceleration and deceleration
- avoid frequent braking
- avoid unnecessarily high speeds
- have all the maintenance jobs specified by us carried out at regular intervals by a MERCEDES-BENZ service station.

Driving in low temperature weather, in stop-and-go city traffic and on short hops, and in hilly country as well, increases fuel consumption.

Owner's
Manual

300 TD-
TURBO DIESEL

Mercedes-Benz



1982

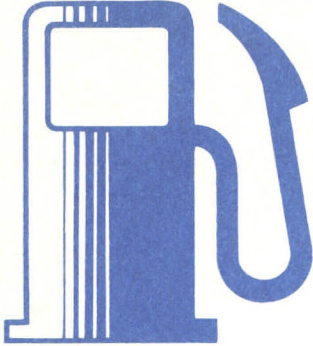

Drive Sensibly-Save Fuel

Fuel consumption depends to a great extent on driving habits and operating conditions.

In order to save fuel you should:

- ensure that tire pressures are correct
- not carry unnecessary loads
- remove ski racks or roof-mounted luggage racks when not in use
- not warm up your engine at idle and with the vehicle at standstill
- avoid frequent acceleration and deceleration
- avoid frequent braking
- avoid unnecessarily high speeds
- have all the maintenance jobs specified by us carried out at regular intervals by a MERCEDES-BENZ service station.

Driving in low temperature weather, in stop-and-go city traffic and on short hops, and in hilly country as well, increases fuel consumption.

Owner's
Manual

300 TD-
TURBO DIESEL

Mercedes-Benz



1982

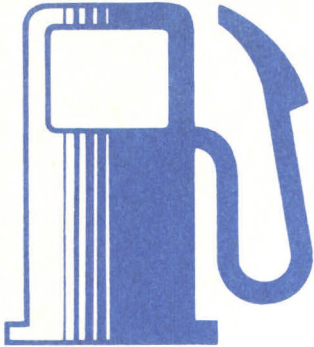

Drive Sensibly-Save Fuel

Fuel consumption depends to a great extent on driving habits and operating conditions.

In order to save fuel you should:

- ensure that tire pressures are correct
- not carry unnecessary loads
- remove ski racks or roof-mounted luggage racks when not in use
- not warm up your engine at idle and with the vehicle at standstill
- avoid frequent acceleration and deceleration
- avoid frequent braking
- avoid unnecessarily high speeds
- have all the maintenance jobs specified by us carried out at regular intervals by a MERCEDES-BENZ service station.

Driving in low temperature weather, in stop-and-go city traffic and on short hops, and in hilly country as well, increases fuel consumption.

300 TD- TURBO DIESEL



9388

Type 123 T
982

You have chosen to drive a MERCEDES-BENZ, a car in whose construction and production we have taken great pains because we believe that quality is not a matter of chance.

Perhaps you have already had experience with a MERCEDES, maybe this is your first car from the DAIMLER-BENZ company.

In both cases — for your own benefit — please read this owner's manual before putting it away. Even though you have been driving a car for years, some things in this car may be new to you, and this manual certainly contains a few hints which will help you to make the most of your new car.

We wish you safe and pleasant motoring.

DAIMLER-BENZ Aktiengesellschaft

Contents

This Owner's Manual also describes optional extras as far as an introduction on their handling is required. As these extras need to be ordered separately, the equipment of your vehicle may deviate from the descriptions and illustrations to some extent.

The last page

What you should know at the gas station

Vehicle Operation

Instruments and Controls	8
Instrument Cluster	10
Keys, Doors	12
Master and Supplementary Keys	12
Opening, Locking and Unlocking of Doors	12
Tailgate	13
Master Lock System	14
Seats	15
Adjustment of Driver's Seat and Front Passenger Seat	15
Safety Headrests	16
Seat Belts	16
Seat Heater	18
Rear Seat Bench	19
Folding Seat Bench	20
Controls	21
Steering Lock	21
Lighting Switch	22
Combination Switch	23
Rear Window Wiper	24
Cruise Control	24
Automatic Climate Control	26
Various Equipment	31
Interior Lamps	31
Sliding Roof	31
Outside Rear View Mirror	32
Inside Rear View Mirror	32
Sun Visor	32
Electric Lighter	33

Heated Rear Window	33
Electric Window Lifters	34
Storage Space below Cargo Space Floor	35
Retractable partition net and Luggage Cover	35
Radio	36

Driving

Hood	46
Regular Inspections	47
Parking Brake	48
Starting and Turning off the Engine	48
Starting and Shifting Gears	50
Safe Driving	52
Brake Pad Wear Indicator Lamp	54
Brake Fluid	54
Charge Indicator Lamp	54
Oil Pressure Gauge	54
Coolant Temperature Gauge	54
Emission Control	55
Engine Oil Consumption	55
The First 1500 km/1000 Miles	55
Special Operating Conditions	56
Winter Driving	56
Hints for Driving	56
Tire Chains	57
High Altitude Correction Device	57
Traveling Abroad	57

Vehicle Care

MERCEDES-BENZ
 Maintenance System 60
 Severe Operating
 Conditions 60
 Engine Oil Change and
 Filter Change 61
 Automatic Transmission —
 Fluid and Filter Change 61
 Spare Parts Service 61
 Cleaning and Care of the
 Vehicle 62
 Jobs related to Care 63

Practical Hints

Ash trays 66
 Bleeding the Fuel System 67
 Turning off Engine Manually 67
 Jack, Vehicle Tools, First Aid Kit
 Spare Wheel 68
 Spare Wheel 68
 Wheels, Tires, Changing
 Wheels 69
 Wheels, Tires 69
 Changing Wheels 70
 Tire Pressure 71
 Checking Fuels, Coolants,
 Lubricants, etc. 72
 Engine Oil Level Check 72
 Checking Coolant Level 73
 Replenishing Coolant 73

Fluid Level — Automatic
 Transmission 74
 Reservoirs for Window
 Washing Systems 75
 Electrical System 76
 Replacing Bulbs 76
 Fuses 79
 Battery 79
 Tow-starting and Towing
 the Vehicle 80
 Jump Starting 81
 Unlocking of the Filler Flap 81

**Technical Data — Fuels,
 Coolants, Lubricants, etc.**

Identification Plates 84
 Vehicle Data Cards 85
 Warranty Coverage 85
 Technical Data 86
 Fuels, Coolants, Lubricants, etc.
 Capacities 88
 Engine Oils 90
 Brake Fluid 90
 Diesel Fuels 91
 Coolants 92
 Service Literature 93

Vehicle Operation ▶

Driving ▶

Vehicle Care ▶

Practical Hints ▶

**Technical Data — Fuels,
 Coolants, Lubricants, etc.** ▶

Vehicle Operation



For more detailed descriptions see quoted pages.

- 1** Speaker grilles
- 2** Swivelling side ventilation outlets (page 26)
- 3** Parking brake release knob (page 48)
- 4** Hood lock release handle (page 46)
- 5** Parking brake pedal (page 48)
- 6** Combination switch (page 23)
- 7** Lighting switch (page 22)
- 8** Cruise control (page 24)
- 9** Instrument cluster (page 10)
- 10** Horn control
- 11** Steering lock (page 21)
Steering lock with preglow/starter switch
- 12** Swivelling outlets for cooled air (page 26)
- 13** Switch for rear passenger compartment lamp (page 31) and switch for rear window wiper (page 24)
- 14** Switches for rear window wiper (page 24)
- 15** Switch for automatic antenna (page 38)
- 16** Switch for heated rear window (page 33)
- 17** Automatic climate control (page 26)
- 18** Radio (page 36)
- 19** Ash tray with electric lighter (page 33, 66)
- 20** Switch for left front seat heater (page 18)
- 21** Switch for hazard warning flasher system
- 22** Switch for right front seat heater (page 18)
- 23** Switch group for window lifters (page 34)
- 24** Loudspeaker — fader control
- 25** Glove compartment, illuminated (only if steering lock is in position “1” or “2”)
To open, move handle sideways

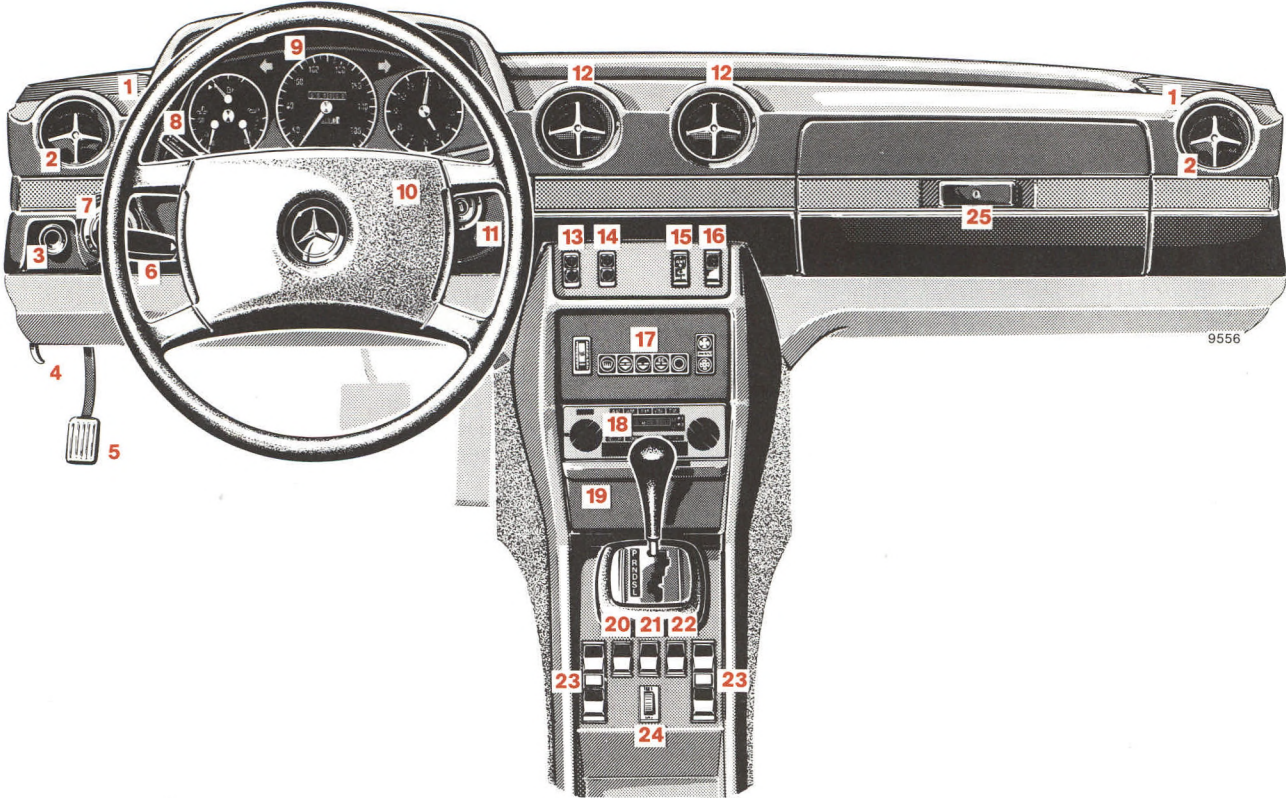

- 
- 1** Coolant temperature gauge ($^{\circ}$ C)
Up to red marking: Maximum permissible temperature for an antifreeze-blended fill protecting down to -30° C / -22° F. See page 54
 - 2** Fuel gauge with reserve warning lamp (yellow)
Fuel reserve and capacity, refer to page 89 and last page
 - 3** Oil pressure gauge (bar). See page 54
 - 4** Turn signal indicator lamp, left (green)
 - 5** Main odometer
 - 6** Trip odometer
 - 7** Turn signal indicator lamp, right (green)
 - 8** Tachometer
 - 9** Electric clock
 - 10** Preglowing indicator lamp (yellow)
 - 11** Seat belt warning lamp (red)
 - 12** Knob for clock adjustment
(press in for adjustments)
 - 13** Knob for instrument lamps and trip odometer
Rotate knob: instrument lamps intensity are infinitely variable
Depress knob: trip odometer is turned back
 - 14** Brake warning lamp (red) comes on if
 - the parking brake is engaged
 - too little brake fluid is in the reservoir
 - 15** Brake pad wear indicator lamp (yellow):
Lights up during braking if the front wheel brake pads are worn down. See page 54
 - 16** Charge indicator lamp (red):
Comes on when the steering lock key is moved to driving position "2" and must go out when the engine is idling. See page 54
 - 17** High beam indicator lamp (blue)

Note

A stop is provided on the speedometer at the 138 km/h/85 mph reading. Speeds in excess of 138 km/h/85 mph will no longer be recorded.

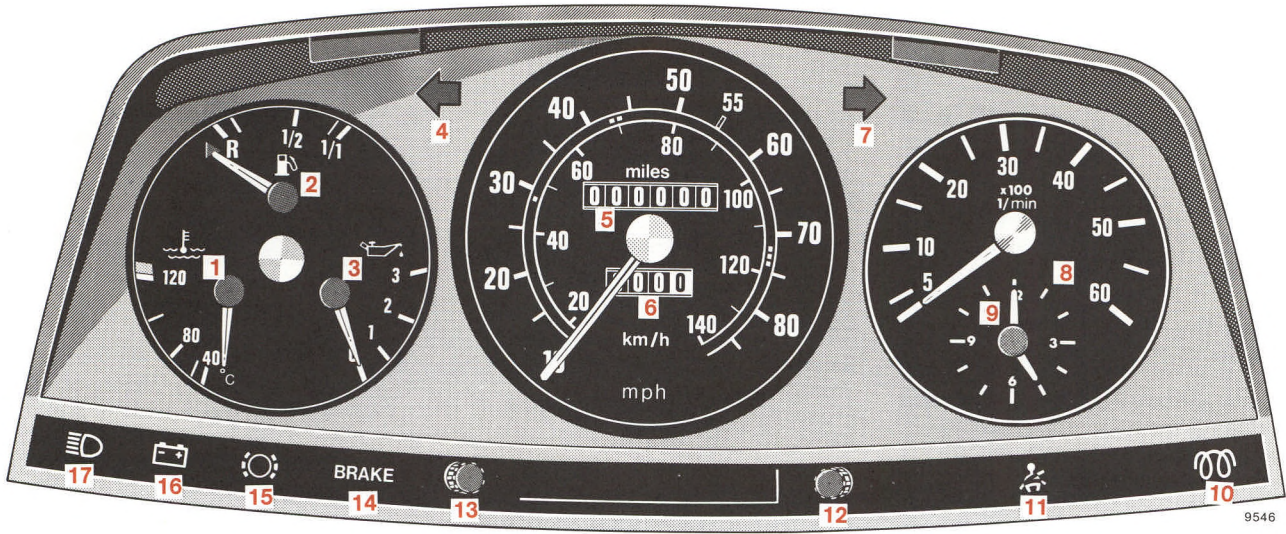

9546

Keys Doors

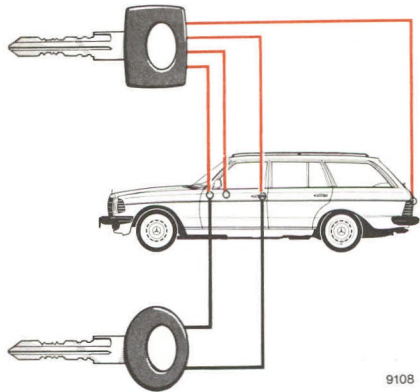

9108

Master Key — square-headed — fits all locks on the car.

Supplementary Key — rounded head — fits only the door locks and the steering lock. This key is intended to be used whenever the car is left with an attendant. Be sure to lock glove compartment and tailgate with the master key.

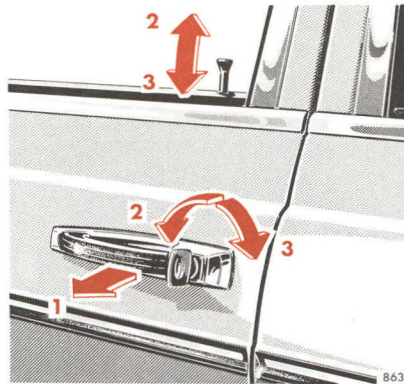

8637

Opening the Doors

Side door

From outside: pull handle (1).

From inside: pull handle in door trim panel.

Tailgate

From outside: push button (1).

From inside: pull handle in door trim panel.

Locking and Unlocking of Doors

From the outside: turn key.

From the inside: actuate safety plunger.

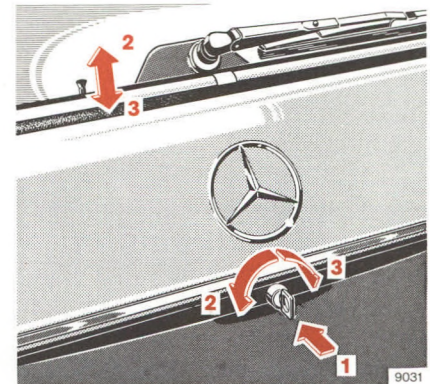

9031

2 Unlocking

3 Locking

The rear doors and the tailgate cannot be opened from the outside or the inside when the plungers are pushed down. They can be opened after pulling plungers up.

One cannot lock:

- the driver's door if it is open
- any door if the door lock has not engaged fully. In this case open the door and close it again.

Tailgate

Only drive with the tailgate closed as otherwise exhaust fumes may enter the vehicle interior.

The rear license plate can be seen correctly only when the tailgate is closed.

To close the tailgate, take hold of grabstrip and press down.

The rear compartment lamp will be switched off by the contact switch only if the tailgate is fully closed.

Note:

Lock tailgate prior to washing the vehicle in an automatic car wash. The washing brush could otherwise cause it to open.

Master Lock System

The master lock system will lock or unlock the vehicle doors and the tank filler flap whenever the driver's door is locked or unlocked.

As the driver's door plunger is moved, the plungers of all other doors must move at the same time. If this is not the case, the lock of the corresponding door has not engaged fully. Open the door once more and close it correctly.

With the master lock system engaged the safety plungers of the front passenger door, the rear doors and the tailgate can also be actuated manually. The front passenger door and the tailgate can in addition be locked and unlocked with the key.

The master lock system can only be applied by depressing the plunger of the driver's door. Lock plungers of the other doors cannot be depressed individually.

The tailgate can also be locked independently of the master lock system. Turn the main key clockwise as far as it will go and withdraw. Every time the driver's door is unlocked, however, the tailgate lock will unlock and can be locked again with the main key if needed.

The master lock system operates on vacuum generated by the engine. A reservoir allows the master lock system to be actuated about five times after the engine is turned off. If the system can then no longer be engaged, idle engine for a short period.

If no vacuum is available, doors and tailgate have to be locked individually in the normal manner. The fuel tank filler flap, however, remains unlocked.

Note:

If the filler flap cannot be opened when the master lock system is unlocked, refer to "Unlocking of the Filler Flap" (page 81).

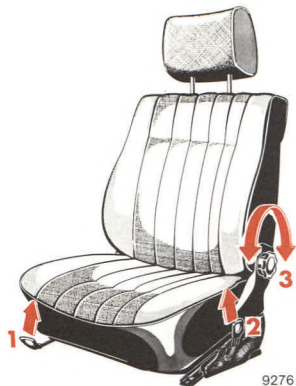

Adjustment of Driver's Seat and Front Passenger Seat

Forward and backward adjustment: lift handle (1); slide seat to desired position and allow handle to reengage.

Height of seat: raise lever (2); to raise seat, move seat forward; to lower seat, move seat backward; allow lever to reengage.

Seat back position: turn handwheel (3) forward or backward. For full reclining of backrest, seat should be moved to one of the forward-most positions and headrest removed. For

driving, return backrest to upright position and push seat back. Replace headrest.

Note:

Prior to operating the vehicle, the driver should adjust the seat height for proper vision as well as fore-aft placement and seat back angle to insure adequate control, reach, operation, and comfort. The headrest should also be adjusted for proper height so that when the cushion is tipped completely forward, it should form a cradle behind the seat occupant's head. Both the inside and

outside rear view mirrors should then be adjusted for adequate rearward vision. Fasten seat belts. Children under the age of six or under the weight of 23 kg/50 lb should be seated in the back seat with an approved restraint system properly secured. All seat, headrest, and rear view mirror adjustments as well as fastening of seat belts should be accomplished before the vehicle is put into motion.

Seats

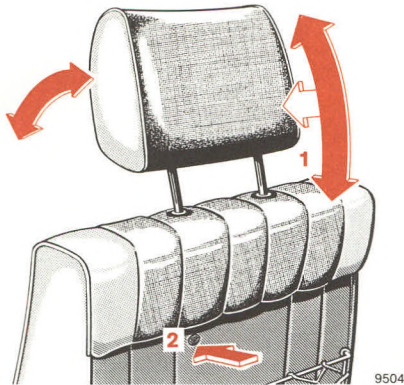

Safety Headrests

Adjust headrest to support the back of the head approximately at ear level. Rear seat headrests can only be adjusted in height.

Height adjustment:

Press headrest slightly forward (1) and reset upward or downward.

Detaching front seat headrests:

Pull headrests up to the stop. Release arrester by depressing locking knob (2) to be felt under the backrest covering material below the LH headrest post and pull up headrest holding it by the LH headrest post (viewed in driving direction). Finally pull out headrest with both hands.

Detaching rear seat headrests:

Pull out headrest to the stop. Release lock by pressing the visible locking button below the LH headrest prong and pull up headrest by LH headrest prong (as seen in driving direction). Then pull out headrest with both hands.

Hint:

Do not confuse the head restraints for front and rear seats.

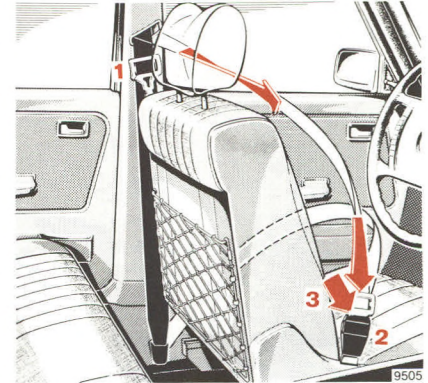

Seat Belts

Warning system:

The indicator is illuminated for 4–8 seconds after turning the steering lock key to position "2". If the seat belt of the driver's seat is not fastened a warning buzzer sounds simultaneously.

Fastening:

- Pull belt with latch plate (1) over shoulder and lap. The belt must not be twisted.

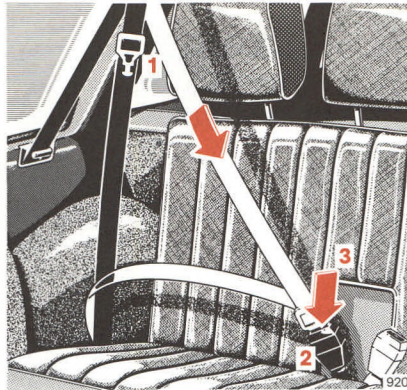
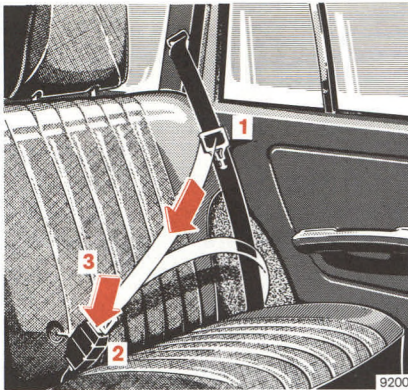

- Press latch plate (1) into buckle (2) and allow to engage audibly.
- The belt must be tight and must be checked for tightness immediately after fastening and regularly during the trip. If required, tighten lap belt by pulling up on the upper belt section.

Unfastening:

- Depress red button (3) in buckle.
- Return latch plate (1) to initial position.

Operation:

The seat belt inertia reel stops the belt from unwinding further in case of vehicle deceleration in any direction or if the belt is pulled out quickly.

Functional test:

The locking function of the inertia reel can be tested by braking, driving around a bend or by pulling the belt out quickly.

Lap belt in the rear:

To fasten the lap belt, pull belt end across your lap and insert the latch plate in the buckle. The belt must not be twisted and must be tight.

To shorten the belt, pull the loose belt end. To lengthen the belt, turn latch plate so that it is at right angles to the belt webbing and pull the belt.

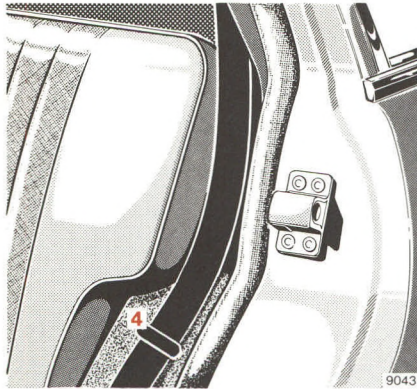

Before folding down the rear seat backrest, slip belt webbing into belt retainers (4) and return latch plate of buckle upward to belt webbing outlet. If the folding seats are not being used, engage belt webbing into brackets (5).

Note:

No seat belt can be used for more than one person. Belts are not intended for children.

After an accident, inspect the seat belts and replace them, if required. The belt anchors in the vehicle should also be checked.

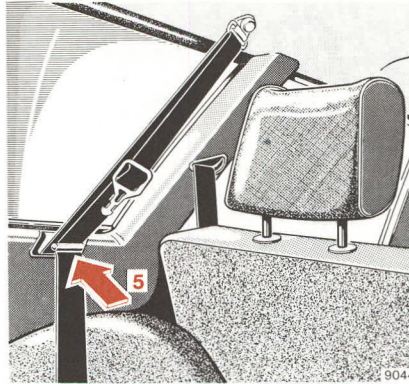

Belt webbing must not be routed via sharp edges. No modifications which may affect the efficiency of the belts must be made. For cleaning and care of belt webbing, refer to page 63.

Seat Heater

The seat heater can be switched on with the steering lock in positions "1" or "2".

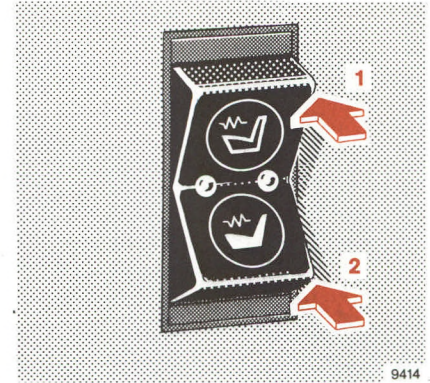

Push switch to position 1 = continuous operation. The indicator lamp in the switch comes on. Push switch to position 2 = rapid heating. Both indicator lamps in the switch come on. Switch in center position = seat heater off.

Due to the relatively high power consumption of the seat heater a heavy load is placed on the battery. For this reason the switch should not be left in position 2 any longer than is absolutely necessary while the engine is switched off.

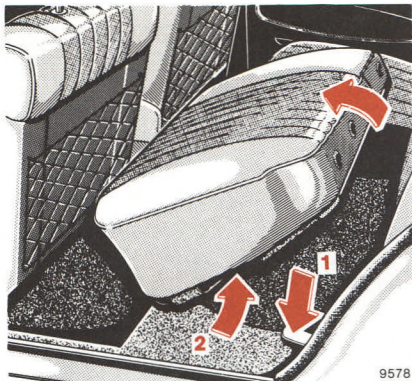

9578

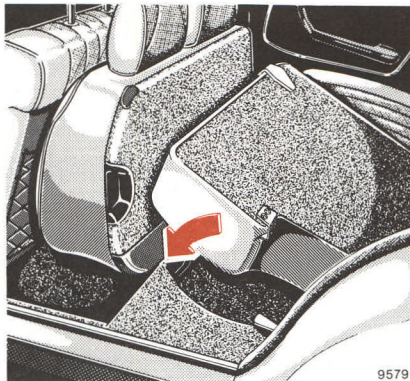

9579

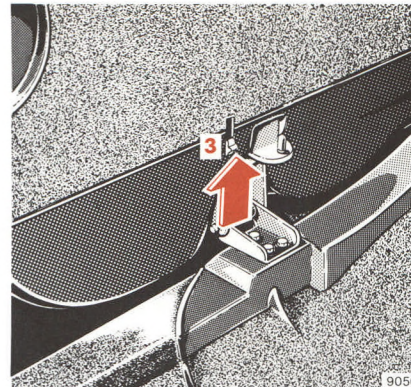

9050

Rear Seat Bench

For the enlargement of the cargo space the left or right section, or both sections, of the rear seat bench can be folded down as desired.

To fold down left or right rear seat bench section, proceed as follows:

Slip seat belt into belt retainer on the wheelhouse and return belt buckle tongue to the belt outlet opening.

Detach headrests.

Push button (1), slip your fingers into recess (2) and position seat cushion vertically (push front seat forward a little, if necessary).

Slide headrest into openings provided (in the seat cushions).

Push button (1) once more and fold backrest forward.

When folding back the backrest and the seat cushion, ensure that they engage in their locks.

Further enlargement of the cargo space:

Remove folded up seat cushion. To do this, push buttons (3) on LH and RH sides and pull seat cushions out of the hinges.

With the backrest folded down the hinge pins must rest in the brackets at the backrest.

When installing the seat cushion, be sure both hinges are engaged.

In addition, when transporting extremely long items, push forward front passenger seat, remove headrest and lower backrest to the rear.

Notes:

It must be ensured that

- the cargo cannot endanger driver and front passenger under hard braking or in the case of a head-on collision.
- the heating filaments of the rear window heater will not be damaged by pieces of luggage rubbing against them.

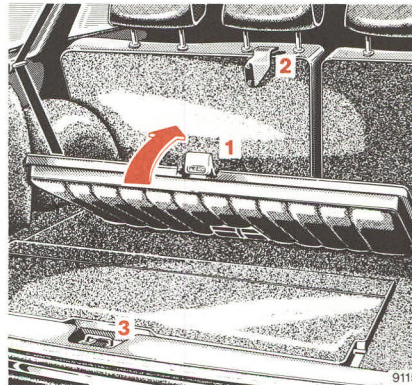

Folding Seat Bench

To enlarge the seating area the folding seat bench can be unfolded. For this purpose, engage the safety belts into the brackets provided. Swing up handle (1) and lift up backrest. The handle must engage above bracket (2).

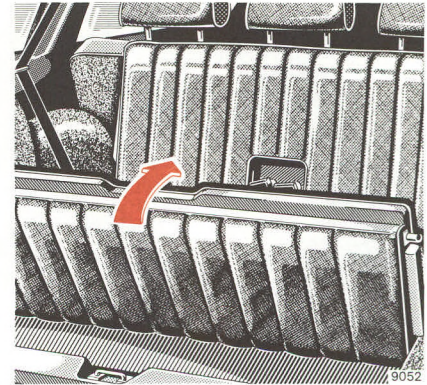

Slip fingers into recess (3) and fold over seat cushion.

Prior to folding back the backrest, lift handle (1) over bracket (2).

Note:

If the folding seat bench is occupied, the rear seat bench must be equipped with headrests.

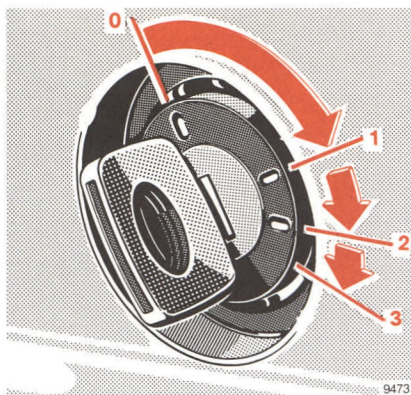

Steering Lock

- 0 Steering is locked when the key is withdrawn and the steering lock is engaged. The key can be withdrawn only in zero position.

Note:

Do not remove key from steering lock while the vehicle is in motion as this will cause the engagement of the steering lock thus rendering the vehicle inoperable.

- 1 Steering is unlocked.
(If necessary, move steering wheel slightly to turn the key clockwise to position "1".)
- 2 Preglowing and driving position.
- 3 Starting position.

For starting and turning off the engine, refer to page 48.

Notes:

The following items can be operated with the key in steering lock position "1".

Wiper, windshield washers, headlamp flasher, electric lighter, glove compartment lamp, radio, electric seat heater.

The power supply to the standing lamps is disrupted if the key in the steering lock is in position "2".

A warning buzzer sounds when the key has been left in steering lock positions "1" or "0" and the driver's door is opened.

With the engine at idle speed, the charging rate of the alternator (output) is limited.

It is therefore recommended to turn off unnecessary electrical consumers while driving in stop and go traffic. This precaution helps to avoid draining of the battery.

An effective measure to preserve battery power is to turn off the following consumers:

Seat heater, heated rear window and fog lamps.

Controls

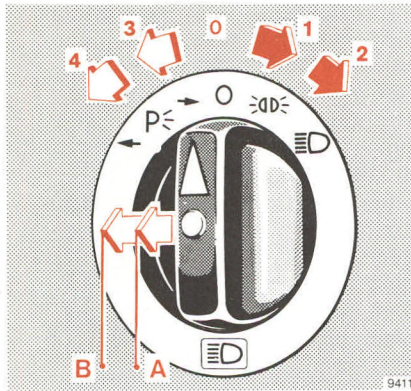

Lighting Switch

- 0 Off-position
- 1 Parking lamps (includes side marker lamps, tail lamps, license plate lamps, instrument panel lamps)
- 2 Same as pos. 1 plus headlamps
- 3 Standing lamps, right
- 4 Standing lamps, left
- A Turn to position 2 and pull out to first detent = same as position 2 plus fog lamps
- B Available for an option

Note:

With the steering lock key removed and the driver's door open a signal sounds if the vehicle's exterior lamps are not switched off (standing lamps excepted).

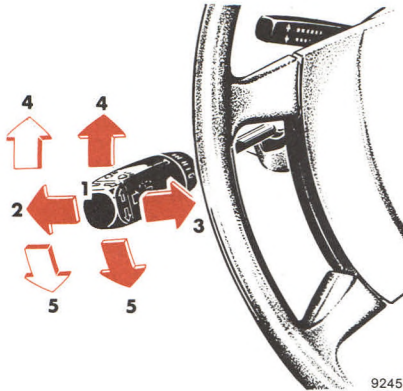

9245

Combination Switch

- 1 Low beam (turn lighting switch clockwise two notches)
- 2 High beam (turn lighting switch clockwise two notches)
- 3 Headlamp flasher (high beam available independent of lighting switch position)
- 4 Turn signals, right
- 5 Turn signals, left



9346

- 6 Control for windshield washer system

When the washer system is switched on, the wipers also operate.

- 7 Windshield wiper control
 - 0 Windshield wiper switched off
 - I Intermittent wiping
 - II Normal wiper speed
 - III High wiper speed

Hints:

If one of the turn signals fails, the turn signal indicator system flashes and sounds at a faster sequence than under normal operating conditions.

Fog lamps will only operate together with low beam headlamps. Fog lamps are turned off automatically when lighting switch is returned to off-position.

To operate the turn signals, move the combination switch past the point of resistance (up or down). The switch is automatically cancelled when the steering wheel is turned by a large enough angle.

To signal minor directional changes of the vehicle, such as changing lanes on a highway, move combination switch to the point of resistance only and hold it there.

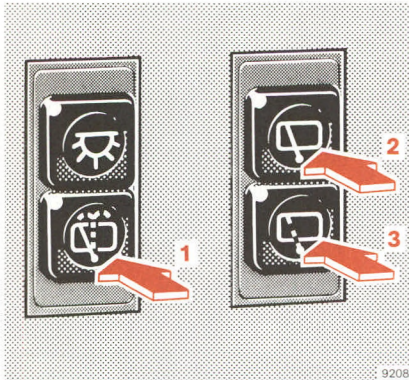

Rear Window Wiper

Push button 1 (will not engage) = operation of window washing system. The wiper is actuated with the washing system.

Push button 2 (engages) = wiper switched on.

Push button 2 once more = wiper switched off.

Push button 3 (engages) = intermittent wiping.

Push button 3 once more = wiper switched off.

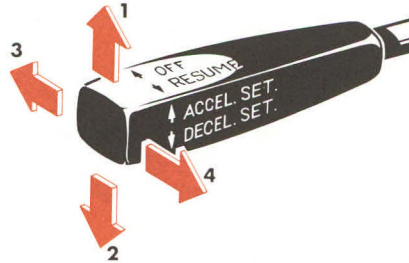

8623

Cruise Control

Any given speed above approximately 40 km/h/25 mph can be maintained with the cruise control by operating the switch.

1 = Setting (touch switch)
Accelerating (hold switch)

2 = Setting (touch switch)
Decelerating (hold switch)

Normally the vehicle is accelerated to the desired speed with

the accelerator. Speed is set by briefly pushing the switch to position "1" or "2", and the accelerator can be released. The speed can be increased (e.g. for passing) by using the accelerator. As soon as the accelerator is released, the previously set speed will be resumed automatically.

If a set speed is to be increased or decreased slightly, e.g. to adapt to the traffic flow, retain switch in position "1" or "2" until the desired speed is reached. When the switch is released, the newly set speed remains.

3 = Cancelling
To cancel the cruise control, briefly push lever to position 3. The cruise control will also be cancelled if the brake pedal is actuated or if the vehicle speed drops below 40 km/h/25 mph.

4 = Resume

If the lever is briefly pushed to position "4" when driving at a speed exceeding approximately 40 km/h/25 mph, that speed is resumed which was set prior to the cancellation of the cruise control. The last memorized speed is cancelled when the key in the steering lock is turned to position "1" or "0".

Important:

Only use the cruise control if the traffic conditions make it advisable to travel at a steady speed.

Position "Resume" should be engaged only if the driver is fully aware of the previously set speed and wishes to resume this particular preset speed.

When driving with the cruise control, the selector lever must not be shifted to position "N" as otherwise the engine will overrev.

Automatic Climate Control

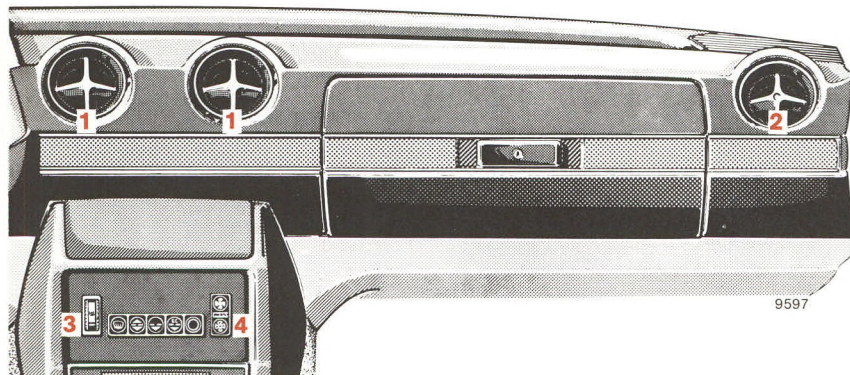

Effective operation of the climate control system can only be assured with all windows and the sliding roof kept closed.

The proper use of the automatic climate control system will add considerably to your comfort (well-being).



The ACC unit will work only with the engine running.

Heating, cooling and air distribution within the vehicle's interior (tri-level) is automatically controlled. Furthermore, settings are available for extreme weather conditions, enabling the defogging of the windshield or air ventilation to top and bottom. This is accomplished with the temperature selector 3, the push buttons, and the blower switch 4.

The movable nozzles (1) and (2) can be opened or closed as desired. Turn clockwise to open.

For good operation of the automatic climate control system, the movable nozzles (1) and (2) may not all be closed.

All push buttons and blower control buttons should only be operated individually. The indicator lamps in the individual buttons light up when pressed with the lighting switch in position (1) or (2).

We strongly recommend settings  and  only, in connection with the desired blower setting. The following instructions explain the remainder of settings for special purposes.

Temperature Selection (° C)

 The interior temperature can be adjusted infinitely by turning the temperature selector wheel. The selected temperature is reached as quickly as possible and maintained. A basic setting of 22° C/72° F is recommended. In order to avoid undesirable temperature fluctuations, a set temperature should be readjusted in small increments only.

To override the automatic climate control, turn the temperature selector wheel to either end position notches “Max” or “Min”.

“Min” (notched-in) = Peak cooling performance, whereby 80 % of the air is recirculated and 20 % of outside air is introduced. If the blower control is set to “AUTOM”, it will run continuously in speed No. 5.

“Max” (notched-in) = Maximum heating performance. If the blower control is set to “AUTOM”, it will run continuously in speed No. 5.

Blower Setting

 Selection for blower settings can be made as follows:

 Push upper button for maximum air supply (6th blower speed).

Push lower button for minimum air supply (1st blower speed).

Push middle button (spring loaded) for automatic control of air supply within 2nd through 5th blower speed range.

Setting  = Always maximum air supply.

Functions

 Off

In this setting, the air supply to the interior of the car is shut off, (in case of bad odor or automatic car wash). Use this setting only temporarily while driving.

Automatic Climate Control

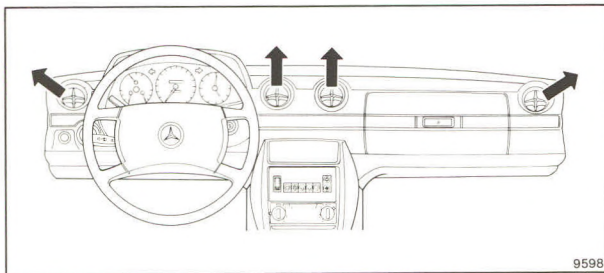

9598

 Economic setting — Ventilation

 Normal setting — Cooling

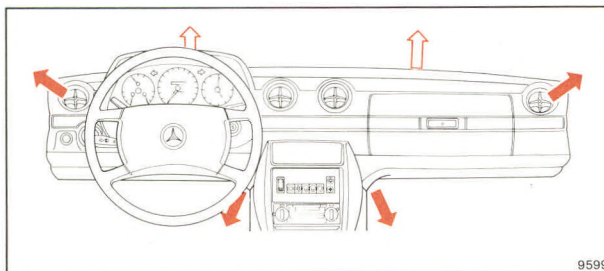

9599

 Economic setting — Heating

 Normal setting — Heating

 EC (ECONOMY) = Economical setting; the air conditioning compressor stays off.

In any other settings, the air conditioning compressor comes on with ambient temperatures above $+2^{\circ}\text{C}/+36^{\circ}\text{F}$.

We recommend this setting to be used with cool outside temperatures so that the air conditioning compressor stays off in order to save fuel.

In the ventilation mode, only air will be channeled to the movable nozzles (1) and (2).

In the heating mode, warm air will mainly be channeled to the leg room. Only an amount of air sufficient to prevent fog build-up under normal climatic conditions will be channeled to the windshield and the movable nozzles 2. At times, air will be emitted from the movable nozzles 1.

With cold outside temperatures, the fresh air supply and the blower remain turned off until the engine coolant has warmed up slightly.

 Normal Setting

We recommend this setting with humid and warm outside temperatures.

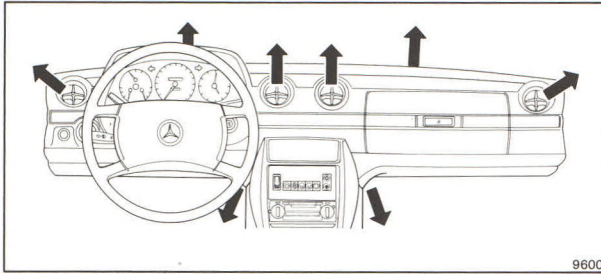

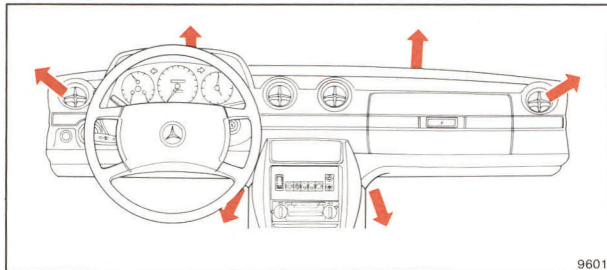

9600

 Bi-Level ventilation — Cooling





9601

 Bi-Level ventilation — Heating

The setting  corresponds with setting  but, in addition, the air is being cooled or preheated as necessary.

Bi-Level

This setting is necessary for clearing a fogged windshield. As soon as possible, reset to  or . In the heating mode, air will be channeled to the windshield, the leg room and to the movable nozzles (2); in the cooling mode, additionally to the movable nozzles (1).

In the heating mode, air will be emitted from the movable nozzles (1) at times.

Automatic Climate Control

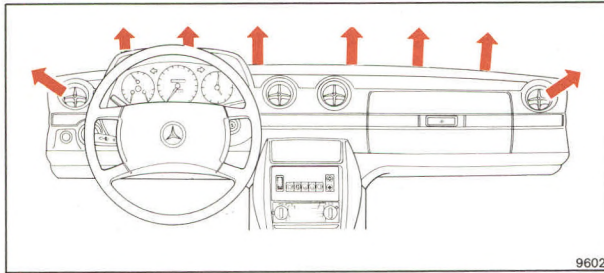



 Defrosting

Defrosting

Independent of the position of the temperature selector wheel and the blower speed setting, optimally heated air will be channeled to the windshield and the movable nozzles (2).

Important!

To ensure proper operation of the automatic climate control system, engage buttons  or  at least once a month for a short period when the outside temperature is above + 2° C/ + 36° F.

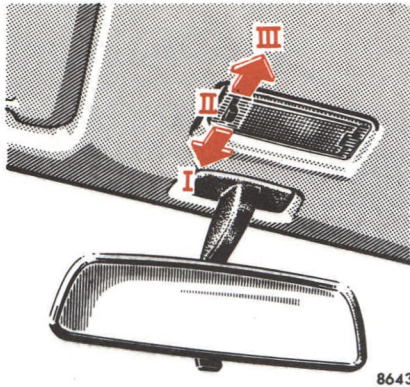

8643

Interior Lamps

The switch for the front lamp has 3 positions.

Position I: lamp is switched on and off by the front door contact switches.

Position II: lamp is continuously switched off.

Position III: lamp is continuously switched on.

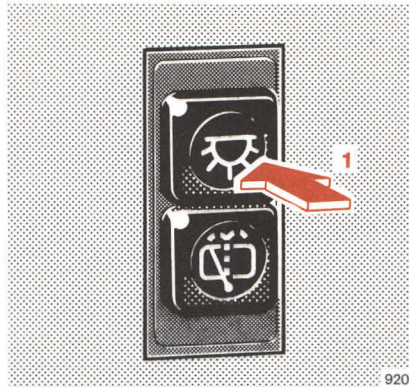

9209

Rear passenger compartment lamp:

Push button (1) to switch lamp on, push once more to switch off.

Depending on the position of the switch in the rear passenger compartment lamp, the lamp is switched on and off by the contact switches of the rear doors and the tailgate.

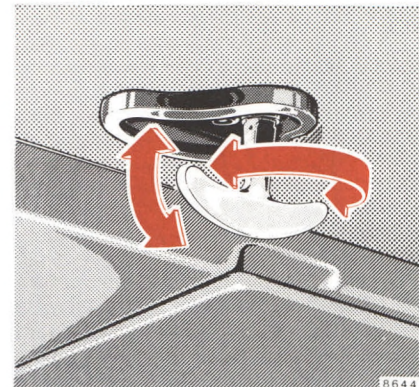

8644

Sliding Roof

To release, swing down locking lever and turn by half a revolution to the stop. Slide roof to the desired position. To secure, turn back the locking lever to the stop and swing up.

Note:

For safety reasons the locking lever must be swung up every time the sliding roof was moved.

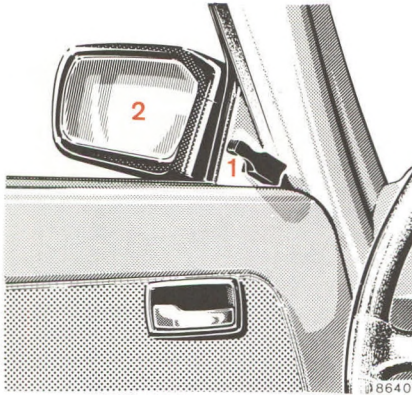

Outside Rear View Mirror

Outside rear view mirror (2) can be randomly adjusted from inside by means of lever (1).

If the mirror housing has been forcibly removed from its safety catch, it must be repositioned by applying firm pressure.

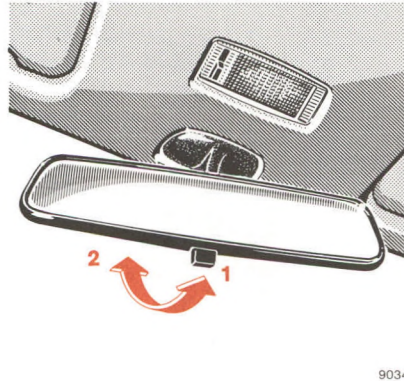

Inside Rear View Mirror

The mirror can be tilted to the anti-glare position by means of the lever at its lower edge.

- 1 = Normal position
- 2 = Anti-glare position

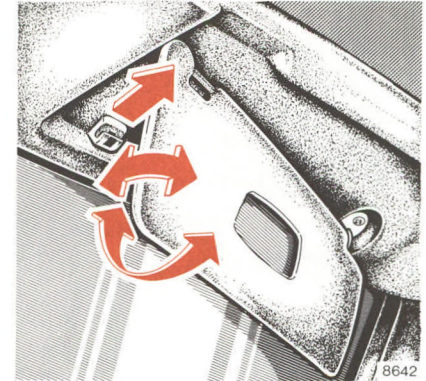

Sun Visor

To protect against sunlight from ahead, fold the sun visor downwards. In the event of strong sunlight through the side windows, remove the sun visor from its inner fixture and swing it sideways.

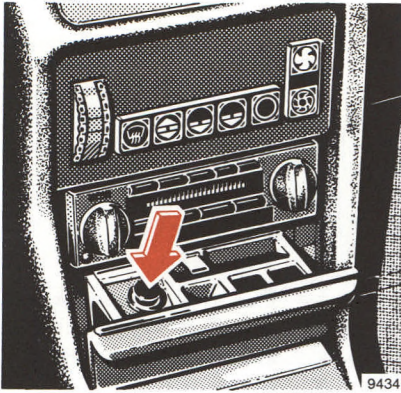

9434

Electric Lighter

Key in steering lock position "1" or "2".

Press in electric lighter; it will pop out automatically when hot.



9345

Heated Rear Window

Turn key in steering lock to position "2".

When the rear window heater is turned on, the white indicator lamp in the switch comes on.

A heavy load is imposed on the battery due to the high power requirement. For this reason, switch off the heated rear window as soon as it is demisted or defrosted. It is shut off automatically after a maximum of 30 minutes. Always remove heavy layers of ice and snow first.

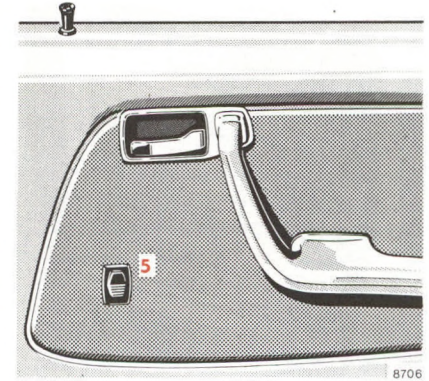
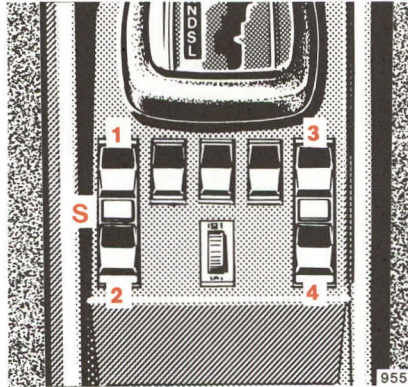

Electric Window Lifters

Switch group for window lifters:

- 1 front, left
- 2 rear, left
- 3 front, right
- 4 rear, right
- S Safety switch

The electric window lifters can only be operated with the steering lock in position "2". All four windows can then be operated using the switches in the center console. The rear door windows can also be operated using the switches (5) in each rear door

panel as long as the safety switch "S" in the safety switch is depressed. If the safety switch is not depressed, inadvertent operation of the rear door windows (for instance, by children) is prevented.

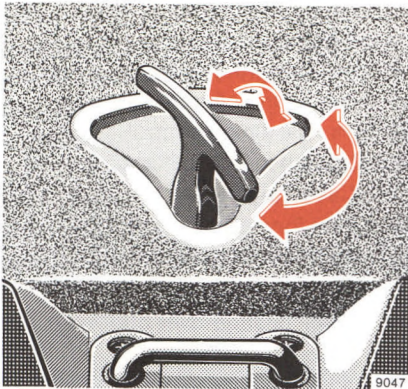

Retractable partition net and Luggage Cover

The twin-reel luggage cover is mounted on the backrest of the rear seat and can also be used with the backrest folded down.

Luggage cover:

Pull out lower blind, draw it over the luggage and engage into eyelets on the tailgate. When the tailgate is opened the blind is lifted up with it so that it need not be wound up for loading or unloading the vehicle.

Storage Space below Cargo Space Floor

Swing up locking lever, turn to the stop and lift up cover. Storage space is available only if the rear facing seat is not installed.

Passenger protection:

Pull out upper spring blind (safety net) and engage into eyelets on the roof. This is a particularly important safety factor when the vehicle is loaded higher than the top of the rear seat backrest.

Removal of double roller blind:

Push turning buttons in on both mounting points located on bottom of blind assembly. Turn buttons by 90° so marks are horizontal. Now lift blind assembly up and out.

Radio

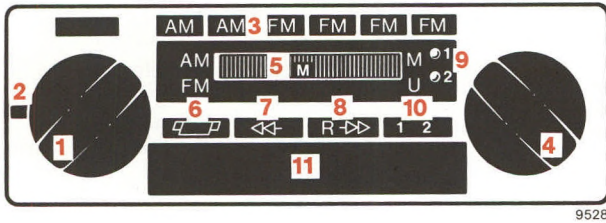

Europa Cassette
(Radio with Pushbutton Tuning and
built-in Cassette Player)

- 1 On-Off/Volume Control
- 2 Tone Control
- 3 Push buttons for band selection and tuning of preset stations
- 4 Manual tuning control
- 5 Wave band indicator
- 6 Cassette release
- 7 Fast forward
- 8 Fast rewind
- 9 Track indicator
- 10 Track change-over button
- 11 Cassette slot

The radio can only be operated with the ignition key in the number "1" or "2" position.

On-Off/Volume

Turn knob (1) clockwise to switch radio on and to increase volume. Green control lamp on the dial will light up.

Tone

Turn lever (2) clockwise to increase treble range and counterclockwise to increase bass range.

Front-Rear Speaker Balance

This control is installed in the center console. Turn rearward to increase volume of rear speakers and forward to increase volume of front speakers.

Station Tuning

Select desired wave band by pushing the respective button (3). The wave band selected is indicated by wave band indicator (5). The desired station is tuned in by turning the manual tuning knob (4). For good reception, accurate manual tuning is important.

To preset stations of various wave bands, pull out preset button (3) to the stop, tune in station with manual tuning knob (4) and push preset button in again to the stop.

FM Reception

FM signals travel in a "line-of-sight". Reflections or "dead spots" may cause cancellations or loss of the signal as well as strong signal overloading or capture.

Lowering the antenna height in strong signal areas may eliminate many of the resulting problems and restore normal reception. However, fringe area reception requires the full antenna length to capture weak incoming signals. The antenna can be operated by depressing the respective side of the rocker switch.

FM Stereo Reception

If an FM stereo station is tuned in, the red Stereo Indicator Lamp will come on. Good quality stereo reception, however, is possible only in areas of high field intensity.

Accurate tuning to the strongest available stereo stations is of particular importance for fringe area reception.

Your radio is fitted with a continuously operating Stereo Decoder which automatically switches the radio from stereo to mono reception if the signal becomes too weak. The Stereo Indicator Lamp remains lit. If the signals of the station tuned in become too weak, the Stereo Indicator Lamp goes out.

The radio will return to stereo mode automatically when signal strength permits.

Tape Playback

Insert cassette (side 1 pointing upwards) into cassette slot and push in to the stop. The radio will then switch over from radio reception to tape playback.

If one side of the tape is finished the player changes over to the other side of the tape automatically (continuous operation).

If tape sides are to be changed while playing, push track changeover button (10).

Track indicator (9) indicates the tape side being played.

To manually eject the cassette, push release bar (6). When the cassette is ejected, the unit will switch over to radio reception automatically.

Push button (7) or (8) for fast forward or rewind of the tape. Briefly touching the counteracting button will stop the winding process.

Care of the Tape Player

Use only good quality cassettes with a maximum playing time of 45 minutes per side (C 90). "Unwound" tapes can be fixed by rewinding either reel with a pencil inserted in its hub. The pick-up head and roller should be cleaned occasionally to maintain the original high quality sound reproduction.

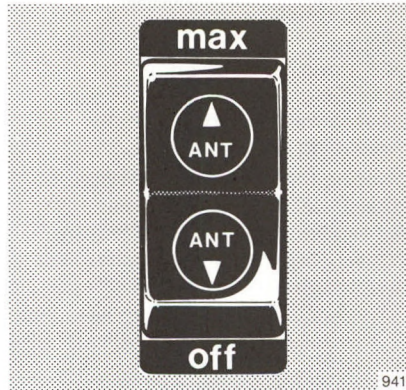

Automatic Antenna

The antenna switch can be actuated with the radio switched on and the key in steering lock positions "1" or "2".

- If the antenna switch is in center position, the antenna extends automatically to a specific height,

- if the antenna switch is engaged in the "max." position, the antenna extends fully,
- if the antenna switch is engaged in the "off" position, the antenna will not extend or will retract completely.

The height of the antenna can furthermore be adjusted continuously by actuating the antenna switch:

- If the antenna switch is in center position, the antenna will extend to a specific height. The antenna can be further extended or retracted to any height by rocking the switch (not engaging it).
- If the antenna is to be retracted e.g. for playing cassettes, engage switch in "off" position.

When the key is turned to steering lock position "0" or the radio is turned off, the antenna will retract completely.

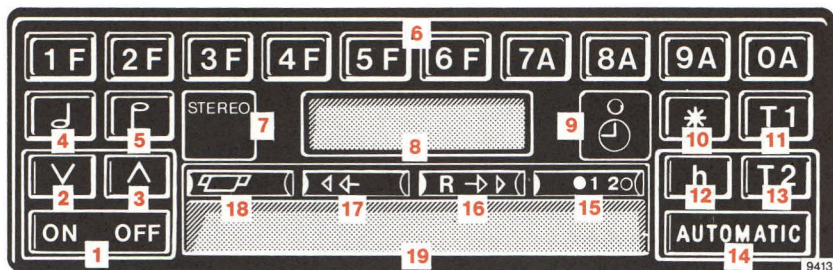

Electronic Radio

- 1 On/Off switch **ON OFF**
- 2 Volume decrease control **∇**
- 3 Volume increase control **∧**
- 4 Bass control **B**
- 5 Treble control **T**
- 6 Push buttons for AM/FM band selection, station frequency selection, station presetting **1 F** through **0 A** and clock setting.
- 7 Stereo indicator light **STEREO**
- 8 Digital display panel for station frequency, station push button number, AM/FM band and time display **101.5 MHz 2**
- 9 Recessed button for setting time **⊖**
- 10 Function control button *****
- 11 Timer button **T1** to control switch-on time of radio
- 12 Time display call button **h**
- 13 Timer button **T2** to control switch-on time of accessory.
- 14 Automatic or manual search station seeker bar **AUTOMATIC**
- 15 Cassette track switch and track indicator **● 1 2 0**
- 16 Fast tape rewind locking button **R → ∇**
- 17 Fast tape forward locking button **∇ ←**
- 18 Cassette eject button **EJECT**
- 19 Cassette door

- 17 Fast tape forward locking button **∇ ←**
- 18 Cassette eject button **EJECT**
- 19 Cassette door

To turn the radio on or off, the ignition switch must be in position "1" or "2".

To turn the radio ON

Press "ON" side of **ON OFF** switch.

The radio will begin operating on the last station tuned to and the last volume and tone setting stored before last turn off.

The radio can also be turned on by inserting a tape cassette through the cassette door.

To turn the radio OFF

Press the "OFF" side of the **ON OFF** switch.

To adjust the volume

To decrease the loudness, press the volume decrease control **∇** ; to increase the loudness, press the volume increase control **∧** .

An additional fader control, installed in the center console of the car, allows for distribution of the audio power between the front and rear speakers.

To adjust the tone characteristic

To set the radio to a "flat" frequency response, briefly press both tone controls **B** **F** simultaneously.

To produce more bass, press the bass control only **B**. To produce more treble, press the treble control only **F**.

Note:

Repeated pressing of either the bass or treble control will cause the respective tone control to alternate between an increasing and decreasing setting.

To select AM or FM

Press any of the buttons marked **1F** through **6F** to tune the radio to the FM band.

Press any of the buttons marked **7A** through **0A** to tune the radio to the AM band.

To tune to a station

Stations can be tuned in by using automatic search, direct frequency dialing, manual tuning, or by preset push buttons. The frequency of the station selected is displayed digitally on the display panel.

Automatic station search

Switch to the wave band desired by pressing any of the following buttons:

for FM, buttons **1F** through **6F**,
for AM, buttons **7A** through **0A**.

By pressing the right side of the station seeker bar **AUTOMATIC**, the radio searches stations in ascending transmitter frequency sequence, and by pressing the left side, in descending transmitter frequency sequence. The direction of the automatic search operation can be reversed by pressing either side of the seeker bar **AUTOMATIC**. For fast approach of a station sought, the seeker bar can be held down.

The radio is programmed to automatically search the entire band in three sensitivity modes. During its first

sweep, only the most powerful stations received will be selected and locked in. During the next sweep, the less powerful and during the third cycle, also the weak stations will be locked in.

If the station seeker bar is reactivated within eight seconds after the radio selects a station, the automatic search will resume in the sensitivity mode used last. If eight seconds are exceeded before reactivating the bar, the unit will again search for the most powerful stations first.

Direct frequency dialing

In order to select a station with a known frequency, select the wave band, press the function button ***** and then enter the frequency by pressing the corresponding push buttons.

Example:

	FM 98.5 MHz	AM 1050 KHz
Press any button marked	1 F through 6 F	7 A through 0 A
Press the function button	*	*
Enter frequency by pressing	9 A 8 A 5 F	1 F 0 A 5 F 0 A

When dialing a frequency directly, the number of the push buttons is not displayed on the panel. The wave band is indicated by showing "MHz" for FM or "KHz" for AM.

Note:

All AM stations have allocated frequencies ending with a "0".

All FM stations have allocated frequencies ending with an odd (uneven) digit after the decimal point.

Broadcasters sometimes may not give their exact frequency but the next closest even number.

US radio frequency ranges: AM 540 – 1600 KHz
FM 88.1 – 107.9 MHz

Manual tuning (used to fine tune a station or for manual scanning)

After selecting the desired AM or FM wave band, press the function control button *****.

Depress and hold the **AUTOMATIC** (left or right side) button. The frequency will increase or decrease respectively in increments of 0.1 MHz for FM or 1.0 KHz for AM. Release the button when the desired station is tuned in.

If, after pressing the function control *****, the station seeker bar **AUTOMATIC** is not activated within eight seconds, the manual tuning mode is ended automatically.

Safety Note

To avoid distraction of attention from the vehicle's operation and the road, it is recommended NOT to perform any manual tuning operations by the driver while the vehicle is in motion. Use the automatic station search operation or preset stations instead.

Push button tuning

Six FM stations and four AM stations can be stored in memory and recalled by pressing the appropriate buttons marked **1 F** through **6 F** for FM or **7 A** through **0 A** for AM stations.

To store stations in memory

Any FM station frequency displayed on the panel can be stored on any button marked **1 F** through **6 F** by depressing the button desired and holding it until the display has changed from the "old" setting to a "blank" and then to the new frequency to be stored.

Showing the “old” setting first allows for reconsideration of the decision to store. If it is desirable to leave the “old” frequency in memory rather than exchanging it with the “new” one, quickly release the button. The “old” frequency will remain in memory.

Any AM station can be stored similarly on any button marked **7A** through **0A**.

Stereo reception

The stereo indicator symbol **STEREO** lights up if a stereo program is received.

The radio is equipped with an automatic stereo/mono switch that electronically switches to mono for clear reception if a weak signal is received. A special circuit provides for a smooth change-over rather than a hard sudden switching, thereby reducing noise and interference.

The stereo indicator will remain lit even if the receiver has changed to the mono mode and will turn off at an antenna signal considered insufficient to provide acceptable reception quality.

Tape Cassette playback



It is recommended to use only good quality cassettes with a playback time of not more than 60 to 90 minutes (C 60) or (C 90).

To start playback, insert a cassette through the cassette door. Push the cassette in until it is locked in its playing position.

When the end of one playing side is reached, the unit switches automatically to reverse for playing the second track.

Manual reverse can be activated by depressing the cassette track switch button . The built-in indicators show the track of the cassette the unit is playing back.

To stop playback, press the eject button . The unit will automatically eject the cassette and switch to radio reception.

For fast tape rewind press the fast rewind button . The button will lock into position until the end of the tape is reached or until the eject  or fast forward  button is activated.

Accordingly, for fast forward transport of the tape, press the fast forward button .

When the radio is turned off by pressing the “OFF” side of the **ON OFF** switch or by turning the ignition key off, the cassette will automatically be ejected.

Care and maintenance

To avoid a deterioration of the tone quality, occasionally clean the tape head with the special cleaner supplied in your glove compartment or available through your dealer.

To set clock

Turn ignition key to position “1” or “2”.

Briefly press recessed time set button  by using a pencil or ballpoint pen.

Enter the time at which you want to start the clock by sequentially pressing four of the top row push buttons **1F** through **0A**. The time entered will be displayed.

Note:

This is a 24 hour clock and time must be entered in all four digits. A 24 hour clock counts time from midnight to midnight, that is 24 hours. A time of 4:28 PM therefore is counted by this clock as 16:28 hours (12 plus 4:28 hours).

Example 1: To enter 7:30 AM,
press buttons **0A**, **7A**, **3F**, **0A**

Example 2: to enter 4:28 PM,
press buttons **1F**, **6F**, **2F**, **8A**

The time entered is now stored. To start the clock in accordance with a time signal or other time reference, again briefly press the recessed time set button **⓪**.

A colon sign will appear between the second and third digits **07:30**, to indicate that the clock is activated.

Normally, the display panel will show the frequency the radio is tuned to.

To display time

Briefly press the call button **h**. The time will be displayed for a few seconds.

To use timers **T1 or **T2****

Timer **T1** can be used to automatically turn the radio on at a preset time. Timer **T2** can be used to turn an accessory (e.g. seat heating system) on at a preset time. To set either timer, the ignition key must be in position "1" or "2". Timer **T1** can only turn the radio on with the ignition key in position "1" or "2". Timer **T2** can turn an accessory on without the ignition key inserted in the lock.

To set timers

Press either **T1** or **T2** button, key desired turn-on time into timer as explained under "setting of the clock". To activate timer, e.g., to turn radio on at the preset time, press *****. A colon sign will appear between the second and third digits to confirm activation.

If, at any time, you would like to know the time either timer is set for, depress either button **T1** or **T2**. The time will be displayed on the panel along with a No. 1 or 2 for the respective timer. After a few seconds, the display will change again to the station frequency tuned to. To change the turn-on time, proceed as outlined under "to set timers".

Note concerning timer **T2**

To connect any accessory to this timer, a special relay is required which can be plugged into the receptacle provided on the radio. Separate instructions are required for this operation.

Driving



Hood

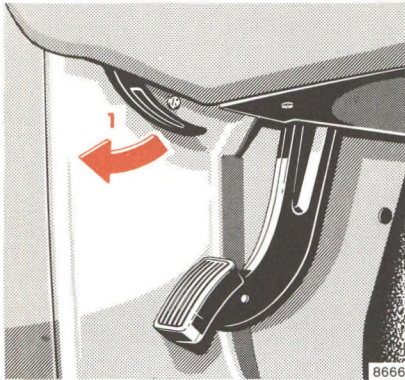

To open:
Pull lever (1) under the LH side of the instrument panel to unlock the hood. The hood opens to the safety catch stop. At the same time grip (2) will pop out of the radiator grille.

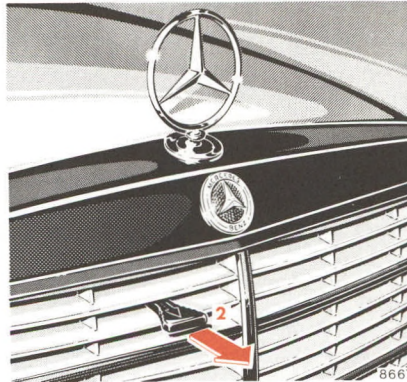

Pull grip (2) out of the radiator grille as far as the stop and lift up hood (windshield wiper arms must not be folded out).
Closing:
Close hood by depressing it firmly.

Note:
There is a risk of injury when the hood is open and the engine is running.

Have the following items checked regularly and prior to any long trip

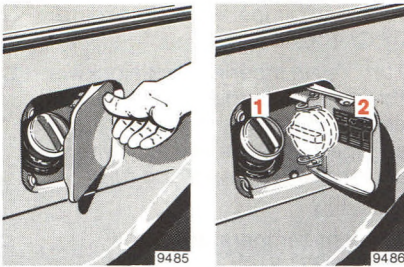

1 Fuel Supply

For winter and summer operation diesel fuels refer to "Fuels, Coolants, Lubricants, etc. and last page".

2 Tire Pressure

For tire pressure table refer to fuel filler flap or last page. Check at least every other week. For further information see "Wheels, Tires, Changing Wheels".

3 Oil/Fluid Level: Engine, Automatic Transmission

See "Checking Fuels, Coolants, Lubricants, etc.", "Fuels, Coolants, Lubricants, etc. and last page".

4 Coolant Level

See "Checking Fuels, Coolants, Lubricants, etc.", "Fuels, Coolants, Lubricants, etc. and last page".

5 Brake Fluid

When the minimum mark on the reservoir is reached, have the system checked (brake lining thickness, leaks).

6 Windshield Washers

Replenish with water mixed with windshield washer detergent (see "Checking Fuels, Coolants, Lubricants, etc.>").

7 Battery

Replenish with distilled water only. See "Electrical System".

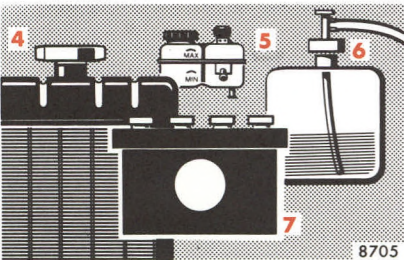
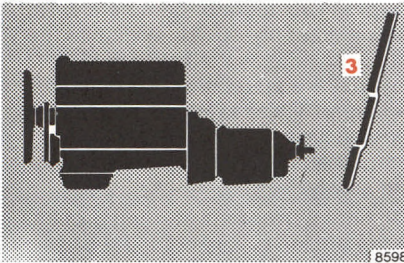

Vehicle Lighting

Check for function and cleanliness.

Parking Brake

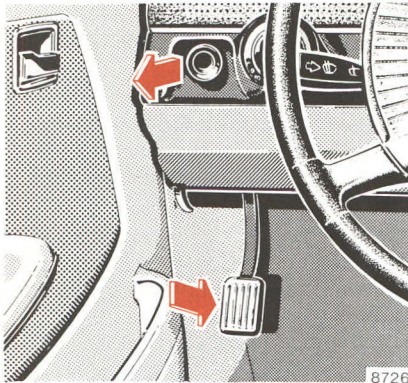

Depress parking brake pedal. When the steering lock key is in position "2", the brake warning lamp in the instrument cluster comes on.

To release, pull release button on the instrument panel. The parking brake releases in one rapid movement. The parking brake warning lamp in the instrument cluster must go out.

Starting and Turning off the Engine

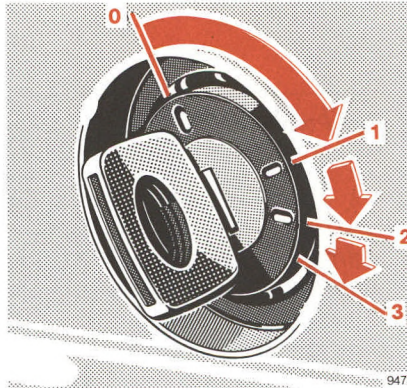

Engage parking brake before starting the engine.

Place the gear selector lever in either "N" or "P" position.

Cold Engine

Turn key in steering lock to position "2". Charge indicator and preglowing indicator lamps must come on. The preglow process starts.

When the preglowing indicator goes out, the engine is ready for starting.

Ambient Temperature exceeding $0^{\circ}\text{C}/+32^{\circ}\text{F}$:

Turn key in steering lock clockwise to the stop. As long as the key is held against the stop the starter remains engaged. Release key only when the engine fires regularly and runs smoothly.

Ambient Temperature below $0^{\circ}\text{C}/+32^{\circ}\text{F}$:

Depress accelerator completely. Turn key in steering lock clockwise to the stop. As long as the key is held against the stop the starter remains engaged. Release key only when the engine fires regularly and runs smoothly. Then release the accelerator slowly.

Do not interrupt the starting process. If the engine is very cold, it is possible that it will fail to start on subsequent attempts.

At ambient temperatures of less than $-18^{\circ}\text{C}/0^{\circ}\text{F}$, depress accelerator three times prior to starting.

Hot Engine

Turn key in steering lock clockwise to the stop and start engine immediately without depressing the accelerator. As long as the key is held against the stop the starter remains engaged. Release the key as soon as the engine has started firing.

Turning off

Turn key in steering lock to position "0" and remove only when the vehicle has stopped.

Should the engine continue to operate with the key in steering lock position "0", refer to page 67.

With very high coolant temperatures (e.g. after driving on mountain passes), do not shut down the engine immediately but allow to run at slightly increased idle speed it for another 1 – 2 minutes approximately.

Notes

Due to the installed starter non-repeat unit, the key in the steering lock must be returned to "0" position before making a new starting attempt.

Observe the oil pressure gauge immediately after starting. In a very cold engine the oil pressure will only rise slowly, some time after the

engine has started. Do not speed up the engine before pressure is registered on the pressure gauge.

The charge indicator lamp must go out as soon as the engine has started. If the preglowing indicator fails to light up, the preglowing system is defective and should be repaired at a MERCEDES-BENZ service station at the earliest possible date.

In areas where temperatures frequently drop below $-18^{\circ}\text{C}/0^{\circ}\text{F}$, we recommend to have a coolant preheater installed. Every MERCEDES-BENZ service station will readily advise you on this subject.

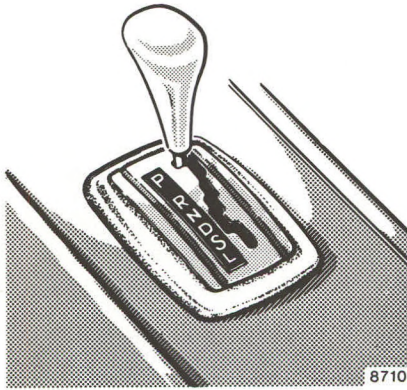

The automatic transmission facilitates and simplifies the handling of the vehicle. The individual gears are shifted automatically dependent upon selector lever position, vehicle speed and accelerator position.

Hint

When parking the vehicle or if working on the vehicle with the engine running, depress parking brake pedal and move selector lever to position "P".

Do not store any objects in the driver's footwell area because they could become lodged under the operator's pedals thus rendering these controls partially or totally inoperative.

Starting

Shift selector lever to the desired driving position only when the engine is idling and the service brake is applied. Do not release the brake before moving off. The vehicle may otherwise start creeping when the selector lever is in a driving position. Test the service brake shortly after driving off.

Warm up the engine smoothly. Do not place full load on the engine until the operating temperature has been reached.

Accelerator position.

Partial throttle = early upshifting = normal acceleration.

Full throttle = retarded upshifting = maximum acceleration.

Depressing the accelerator beyond full throttle to kickdown position means downshifting to the next lower gear and thus maximum acceleration. If you ease up on the accelerator after having attained the desired speed, the transmission will shift up again.

Gearshifting is controlled by the vehicle speed.

Selector lever positions

The automatic gear shifting process can be adapted to specific operating conditions by means of the selector lever.

“P” Parking lock.

The parking lock is an additional safeguard when parking the vehicle. Engage only when the car is stationary.

“R” Reverse gear.

Shift reverse gear only with the vehicle at halt.

“N” Neutral.

No power is transmitted from the engine to the rear axle.

When the brakes are released, the vehicle can be moved freely (pushed, towed or tow-started). Do not engage “N” when driving except when the vehicle is in danger of skidding (e.g. on icy roads). See page 56.

“D” Drive.

All gears are available. Position “D” affords optimum driving characteristics under all normal operating conditions.

“S” Slope.

Upshifting to 3rd gear only. Suitable for moderate ascents and descents. As the transmis-

sion shifts up to 3rd gear only, this position permits the utilization of the engine braking effect.

“L” Low.

Upshifting to 2nd gear only. For driving on steep mountain passes, for trailer operation in mountainous regions, for driving under severe operating conditions and as braking position on extremely steep declines.

Do not exceed top speeds in the individual selector lever positions. Refer to speedometer markings.

Starting and Shifting Gears

Maneuvering

To maneuver in restricted area, e.g. when pulling into a parking space, control the car speed by gradually releasing the service brake. Accelerate gently and do not pump the accelerator. To rock a car out of soft ground (mud or snow), alternately shift one forward gear range and the reverse gear at partial throttle.

Trailer operation

Do not allow the engine speed to drop too low at uphill gradients to prevent the engine from laboring at low RPMs. Depending on the degree of the incline, shift selector lever to

positions "S" or "L" early enough to maintain engine RPMs within best torque range.

Stopping

For brief halts, e.g. at traffic lights, leave the selector lever in a driving position and control vehicle with the service brake.

For longer stops with the engine idling, shift selector lever to position "N" or "P".

When stopping the car on a slope, do not hold it by means of the accelerator but use the service brake. This avoids unnecessary heat-up of the transmission.

Safe Driving

Power assistance:

Do not attempt to move or roll the vehicle with the engine not in operation, as engine-driven accessories such as the power steering system or power brakes are not "powered", therefore, requiring substantially more effort for their operation even though they always remain mechanically operative.

Tires:

Do not allow your tires to wear down too far. With less than appr. 3 mm/ 1/8 in of tread, the antiskid properties on a wet road fall off sharply.

Depending upon the weather and/or road pavement, the grip of the tires varies widely.

The retention of the specified tire pressure is essential. This applies particularly if the tires are subjected to high loads (e.g. high speeds, heavy loads, high or low ambient temperatures).

Aquaplaning:

Depending on the depth of the water layer on the road, aquaplaning may occur even with tires still showing the full tread depth, and even at low speeds. Avoid track grooves in the road and apply brakes cautiously in the rain.

Tire friction:

Dry road = 100 %

Wet road = from approx. 50 % to approx. 80 % (be particularly cautious on wet and dirty roads)

Icy road = approx. 15 %

A given speed at which a vehicle driven on dry roads can still be fully controlled must be reduced when the same vehicle is to be driven safely on a wet or icy road.

You should pay particular attention to the condition of the road as soon as the prevailing temperatures fall close to the freezing point.

If ice has formed on the road (e.g. due to fog), a thin film of water is then

quickly produced on the ice which substantially reduces the grip of the tires. Under such weather conditions, drive, steer, accelerate and brake particularly carefully.

We recommend M + S radial-ply tires for the cold season. On ice or packed snow, they can reduce your stopping distance as compared with summer tires. Stopping distance, however, is nevertheless considerably greater than when the road is wet or dry.

Brakes:

When driving down long and steep declines, relieve the brakes by engaging selector lever position "S" or "L". This prevents overheating of the brakes and reduces brake pad wear.

After hard braking it is advisable not to switch off the engine right away but to drive on for some time so the air stream will cool down the brakes faster.

When driving in heavy rain for some time without applying the brakes, the first braking action may be somewhat retarded and increased pedal pressure may be necessary. For this reason, stay further away from a vehicle in front.

The condition of the parking brake should be checked during every maintenance service. Furthermore it is recommended to exert once or twice between the regular maintenance services, a maximum pressure of 10 kp/22 lb on the parking brake pedal for 10 seconds while travelling at a speed around 50 km/h/30 mph on dry road. Pull release knob during this process! Repeat procedure once or twice. Exercise care, the brake lamps do not work.

Have all inspections of and work on the brake system carried out by a MERCEDES-BENZ service station.



If the parking brake is released and the brake warning lamp in the instrument cluster comes on, the brake fluid level in the reservoir is too low.

Brake pad wear or a leak in the system may be the reason for loss of brake fluid in the reservoir.

Have the brake system inspected at a MERCEDES-BENZ service station without delay.

Install only brake pads recommended by us. If other than recommended brake pads are installed, the braking properties of the vehicle can be affected to an extent that the safety is substantially impaired.

Brake Pad Wear Indicator Lamp

The brake pad wear indicator lamp in the instrument cluster comes on when the key in the steering lock is turned to driving position "2" and it must go out when the engine is running. If the indicator lamp lights up during braking, this shows that the front wheel brake pads are worn down.

Have brake system checked in a MERCEDES-BENZ service station as soon as possible.

Brake Fluid

During the course of the operation of the vehicle, the boiling point of the brake fluid is continuously being reduced through the absorption of moisture from the atmosphere. Under extremely hard operating conditions, this moisture content can lead to the formation of vapor in the system, thus reducing the system's efficiency. The brake fluid must therefore be replaced annually, preferably in the spring. It is recommended to use only brake fluid approved by MERCEDES-BENZ.

Your MERCEDES-BENZ dealer will provide you with additional information.

Charge Indicator Lamp

Should the charge indicator lamp fail to come on prior to starting when the ignition key is in position "2" or should it fail to go out after starting or during operation, this indicates a fault which must be repaired at a MERCEDES-BENZ service station as soon as possible.

Oil Pressure Gauge

The oil pressure may drop at idle speed to 0.5 bar/7.1 psi if the engine is at operating temperature. This will not jeopardize its operational reliability. Pressure must, however, rise immediately upon acceleration.

The oil pressure gauge does not provide any information concerning the oil level in the engine.

Coolant Temperature Gauge

Due to the pressurized cooling system, the coolant only starts boiling at a temperature of approx. 125° C/ 257° F with an antifreeze-blended coolant fill protecting down to -30° C/ -22° F (see also "Fuels, Coolants, Lubricants, etc.")

During severe operating conditions and stop-and-go city traffic the coolant temperature must not rise above the red marking.

Emission Control

Certain systems of the engine serve to keep the toxic components of the exhaust gases within permissible limits required by law. (Nevertheless, we urgently advise you not to let the engine run in a closed garage.) These systems, of course, will function properly only when maintained strictly according to factory specifications. Any adjustments on the engine should, therefore, be carried out only by qualified MERCEDES-BENZ technicians. The adjustments of the engine should not be altered in any way. Moreover, the specified service and maintenance jobs must be carried out regularly according to MERCEDES-BENZ servicing requirements. For details refer to Maintenance Booklet.

Engine Oil Consumption

Engine oil consumption can only be determined after a certain mileage has been covered. During the break-in period, higher oil consumption may be noticed and is normal.

Frequent high engine speed operation will also cause increased oil consumption.

The more cautiously you treat your engine during the break-in period, the more satisfied you will be with its performance later on. Therefore, drive your vehicle during the first 1500 km/1000 miles at moderate vehicle and engine speeds.

During this period, avoid heavy loads (full throttle driving) and high RPMs (no more than $\frac{2}{3}$ of maximum permissible speed in each gear) and do not force the engine to labor at low engine speed.

Avoid accelerating by kickdown. It is not recommended to brake the vehicle by means of manually shifting to a lower gear. We recommend to select positions "S" or "L" only at moderate speeds (for hill driving). After 1500 km/1000 miles speeds may gradually be increased to the permissible maximum.



Winter Driving

Have your car winterized in a MERCEDES-BENZ service station before the onset of winter.

- Engine oil change: If no “all-year round” engine oil is used, fill with recommended winter oil. For viscosity and capacity, refer to “Fuels, Coolants, Lubricants, etc. and last page”.
- For diesel fuels, refer to page 91 and last page.
- Antifreeze in the coolant: Check antifreeze protection periodically. For capacity refer to “Fuels, Coolants, Lubricants, etc.”.
- Additive in the windshield washer systems: Add windshield washer solvent to the water in the windshield washer system.
- Test battery: Battery capacity drops with decreasing ambient temperature. A well charged bat-

tery ensures that the engine can always be started, even at low ambient temperatures.

- Tires: We recommend M + S radial tires on all wheels for the winter season. Observe permissible maximum speed for M + S radial tires and the legal speed limit.

Hints for Driving

The most important rule for slippery or icy roads is to drive sensibly and to avoid abrupt acceleration, braking and steering action. Do not use the cruise control system under such conditions.

When the vehicle is in danger of skidding, move selector lever to position “N”. Try to keep the vehicle under control by means of corrective steering action.

Provided the traffic conditions will allow, only brake in a way that the

wheels are locked for no more than fractions of a second as otherwise the steerability of the vehicle is lost.

Road salts can adversely affect braking efficiency. Increased pedal force may become necessary to produce the normal brake effect. We therefore recommend depressing the brake pedal repeatedly when travelling on salt-strewn roads at length. This can bring road salt impaired braking efficiency back to normal. A prerequisite is, however, that this is possible without endangering other drivers on the road.

If the vehicle is parked after being driven on salt treated roads, the braking efficiency should be tested as soon as possible after driving is resumed while adhering to the safety requirements. Should the braking efficiency have deteriorated considerably it can be improved again by braking several times.

Tire Chains

Tire chains can only be used on the driving wheels. Use only chains tested and recommended by us. Any MERCEDES-BENZ service station will readily advise you. Retighten newly mounted tire chains after a few miles of driving. Do not exceed permissible maximum speed of 50 km/h/30 mph. On clear roads remove the chains as soon as practicable. Adhere to the manufacturer's mounting instructions.

High Altitude Correction Device

The engine is equipped with an automatic high altitude correction device.

Traveling Abroad

Abroad, too, there is a widely-spread MERCEDES-BENZ service network at your disposal. If you travel into areas which are not listed in the index of your service station booklet, you should request pertinent information from your dealer.

Vehicle Care



Like any other mechanical equipment, the vehicle requires care and maintenance.

A maintenance booklet is delivered with your car listing all the maintenance jobs that must be carried out after the following mileages.

- Once after 1300 – 1600 km/ 800 – 1000 miles.
- After 8000 km/5000 miles.
- After 24 000 km/15 000 miles and thereafter every 24 000 km/ 15 000 miles, but at least once every two years.

We would also like to draw your attention to the hints contained in the maintenance booklet covering necessary lubrication services every 8000 km/5000 miles, additional maintenance jobs every 48 000 km/

30 000 miles and MB individual maintenance as required.

Renew brake fluid once a year, preferably in spring. Use only brake fluids recommended by MERCEDES-BENZ.

The vehicle must receive the prescribed maintenance and/or lubrication work at the specified intervals as listed in the maintenance booklet.

Verification of performance of such maintenance/lubrication work should be recorded in the spaces provided in the maintenance booklet.

The maintenance jobs are described in detail in a manual which you can order from your MERCEDES-BENZ service station.

Severe Operating Conditions

In the case of severe operating conditions or heavy use mainly in city traffic or over short distances, frequent mountain driving, poor roads, dusty and muddy conditions, trailer operation, hard and sporty driving, etc., it may be necessary to inspect e.g.

- the tires
- air cleaner (clean or renew element)

at shorter intervals.

Any MERCEDES-BENZ service station will be pleased to give you expert and individual advice.

Engine Oil Change and Filter Change

To be carried out every 8000 km/ 5000 miles, but at least once a year if year-round multigrade oil is used. Otherwise at least twice a year (in spring and fall).

Under severe operating conditions or if diesel fuels with high sulphur content (in excess of 0.5 % by weight) are used, the oil and filter should be changed every 4000 km/ 2500 miles.

For regular oil level checks, refer to "Checking Fuels, Coolants, Lubricants, etc."

Automatic Transmission — Fluid and Filter Change

To be carried out every 48 000 km/ 30 000 miles according to the maintenance booklet.

Under severe operating conditions, have the automatic transmission fluid changed every 24 000 km/15 000 miles without filter change.

All MERCEDES-BENZ service stations maintain a stock of original spare parts required for maintenance and repair work. In addition, strategically located parts distribution centers provide quick and reliable parts service.

More than 200 000 different spare parts, even for rather old vehicle models, are available.

MERCEDES-BENZ original spare parts are subjected to most severe quality inspections. Each part has been specifically developed, manufactured or selected for and adapted to MERCEDES-BENZ vehicles. Therefore, MERCEDES-BENZ original spare parts should be installed.

Cleaning and Care of the Vehicle

In operation, your vehicle is subjected to a great amount of varying external influences which, if gone unchecked, can attack the paintwork as well as the underbody and cause lasting damage.

Such damage is caused not only by extreme and varying climatic conditions, but also by air pollution, road salt, tar, gravel and stone chipping. Grease and oil, fuel, coolant, brake fluid, bird droppings, tree resins, etc. should be immediately removed to avoid paint damage. Frequent washing, however, reduces and/or eliminates the aggressivity and potency of the above adverse influences.

Special car-care measures may be necessary to deal with unfavorable conditions; for example, near the coast, in industrial areas (smoke, exhaust emissions), or during winter operation.

You should check over your vehicle from time to time for stone chipping or other damage. Any damage should be repaired as soon as possible.

In doing so, do not neglect the underside of the car. A prerequisite for a thorough check is a washing of the underbody followed by a rust-proofing treatment.

Your vehicle has been treated at the factory with a wax-base rustproofing in the body cavities which will last for the lifetime of the vehicle. Post-production treatment is neither necessary nor recommended by MERCEDES-BENZ because of the possibility of incompatibility between materials used in the production process and others applied later.

After every engine cleaning you should have the engine compartment rustproofed. Before rustproofing, all control linkage bushings have to be

lubricated with hydraulic oil (check with your local MERCEDES-BENZ dealership for recommended brands).

We have selected car-care products and compiled recommendations which are specially matched to our vehicles and which always reflect the newest in technological standing. You can obtain MB car-care products at every MERCEDES-BENZ service station.

Scratches, corrosive deposits, corrosion or damage due to negligent or incorrect care cannot always be removed with the car-care products recommended here. In such cases it is best to seek aid at your MERCEDES-BENZ service station.

The following topics deal with the cleaning and care of your vehicle and give important "how-to" information as well as references to recommended MB car-care products.

Car Wash

Do not wash the car in the sun. Spray vehicle well with a diffused jet of water. Direct only a weak jet towards the ventilation openings. Use plenty of water and rinse sponge and chamois often. Rinse off vehicle with clear water and wipe dry with chamois.

Do not use solvents (fuels, thinner, etc.) to clean the tail lamps.

In the winter, thoroughly remove all traces of road salt as soon as possible.

When washing the car underbody, do not forget to clean the inner sides of the wheels.

Tar Stains

Quickly remove tar stains before they dry and become more difficult to remove.

Window Cleaning

Use a window cleaning solution on very dirty or oil-stained windows.

Clean windshield wiper blades with a clean cloth and washing solution. Replace blades once or twice a year.

Plastic Parts, Rubber Parts and MB-TEX Upholstery Covers

Do not use oil or wax on these parts.

Seat Belts

The webbing must not be treated with chemical cleaning agents. Use only clear, lukewarm water and soap. Do not dry the webbing at temperatures above 80° C/176° F or in direct sunlight. Never bleach or re-dye the webbing.

Steering Wheel, Selector Lever and Instrument Cluster

Use a gentle dish-washing detergent or mild detergent for delicate fabrics

as a washing solution. Wipe with a cloth moistened in lukewarm solution. Do not use scouring agents.

Upholstery

Leather: Wipe leather upholstery with a damp cloth and dry thoroughly. Exercise particular care when cleaning perforated leather as its underside should not become wet.

Velours: Pressure marks resulting from dampness and heat may appear to be stains. Such marks can be removed by wiping with a moistened brush, ironing with a wet cloth or by treating with a dry shampoo. Do not sit on damp upholstery. Quick drying is achieved by applying hot air — for example, by using a hair dryer. If in doubt, please consult your MERCEDES-BENZ service station.

Cleaning and Care of the Vehicle

Paintwork

Do not apply wax if your car is parked in the sun or if the hood is still hot. For maximum protection, the paintwork should be waxed approximately once every three months. Use the appropriate MERCEDES-BENZ Touch-Up Stick for quick and provisional repairs of minor paint damage.

Light Alloy Wheels

If possible, clean wheels once a week with lukewarm water and auto-shampoo. Use an ample supply of water. To remove stubborn marks, use polish or paint cleaner and apply with buffing cloth or a soft cloth.

Ornamental Moldings (Chrome-Plated, Aluminium)

For regular cleaning and care of very dirty chrome-plated parts, use a chrome cleaner.

Practical Hints



Practical Hints

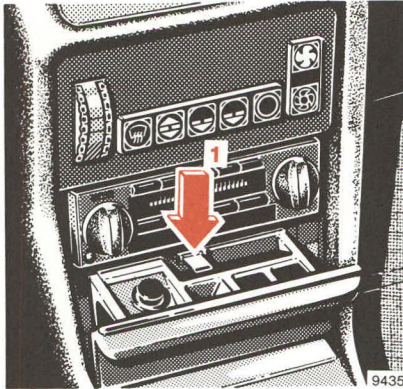

Ash trays

To remove front ash tray:
Pull ash tray out as far as possible.
Push down the spring (1) in the center and remove ash tray.

To install ash tray:
Position ash tray squarely and push in.

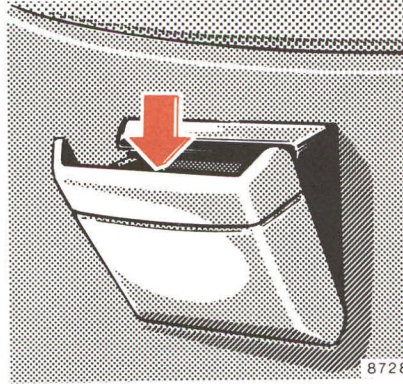

To remove rear ash tray:
Push the ash tray down while opening and remove.

To install ash tray:
Position ash tray squarely and push in.

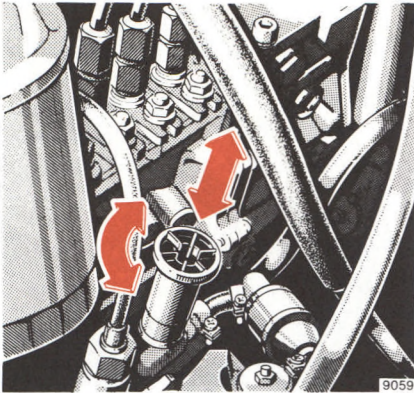

Bleeding the Fuel System

A completely bled fuel system is imperative for perfect engine operation. During operation, the system is continuously bled via the overflow line.

The entire system must be bled manually after the fuel tank has been driven completely empty.

First, fill fuel tank with fuel. Then operate primer pump until the bypass valve on the injection pump opens (hissing noise).

Disengage primer pump handle prior to operating it (turn counterclockwise). Retighten after use.

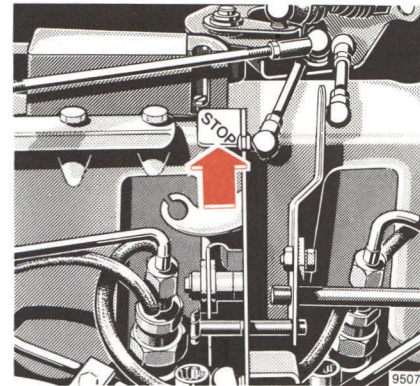

Turning off Engine Manually

If the engine continues operating in steering lock position "0", open hood and press lever marked "STOP" until the engine stops.

Practical Hints

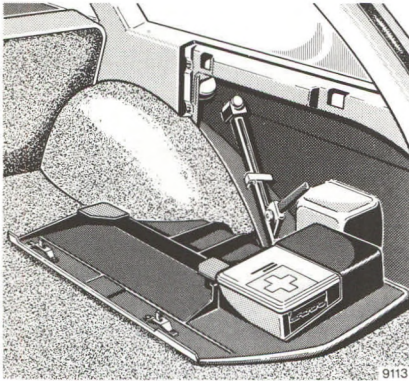

Jack, Vehicle Tools, First Aid Kit

Jack, vehicle tools and first aid kit are stowed in the cargo space on the RH side behind the panel.

To open the panel, pull handle and fold down panel.

Note:

The jack is designed exclusively for jacking up the vehicle at the jack tubes provided on either side of the vehicle. Jack stands must be used when working under the vehicle.

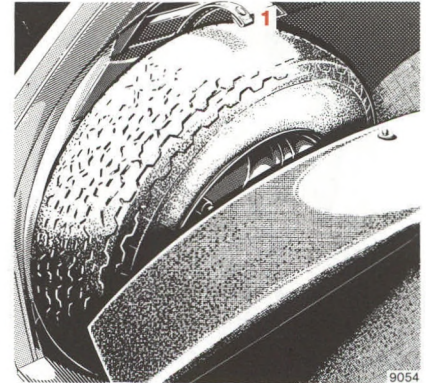

Spare Wheel

The spare wheel is located in the cargo space on the LH side behind the panel.

Open web (1) and lift panel upwards. When attaching the panel, make sure the guide pins engage in the floor of the cargo space.

Wheels, Tires

In case of replacement we recommend you use tires of identical design, version and brand.

See any MERCEDES-BENZ service station for information on tested and recommended wheels and tires for summer and winter operation. They will also offer more advice concerning tire service and purchase.

Mount single newly acquired tires on the front wheels. If any tires are replaced and the spare tire is new and of the same make and version, mount the spare wheel on the vehicle as road wheel. We recommend that you break in new tires for approx. 100 km/60 miles at moderate speed.

On new rims it is imperative that the wheel securing bolts be retightened after approx. 800 km/500 miles. On new vehicles retightening is carried out in the course of the 1st inspection. Retightening is also necessary when new wheels are fitted at a later date, e.g. when the spare wheel is used for the first time or when a new set of wheels with M + S tires is fitted.

For tire specifications, refer to "Technical Data".

Rotating wheels:

The wheels can be rotated according to the degree of tire wear while retaining the same sense of rotation. Rotating, however, should be carried out before the characteristic tire wear pattern (shoulder wear on front wheels and tread center wear on rear wheels) becomes visible at a mileage of 5000 – 10 000 km/3000 – 6000 miles as otherwise the driving properties deteriorate.

Slowly leaking air (e.g. due to a nail in the tire) may cause damage to the tire such as tread separation. Regular tire pressure checks at intervals of no more than 14 days are therefore essential. For the tire pressure checks, keep in mind that hot tires show higher pressure than cold tires. See tire pressure chart on last page.

Should the tire pressure decrease constantly, check whether foreign objects have penetrated the tire or if rim or valve allow the air to leak.

Thoroughly clean the inner side of the wheels any time you rotate the wheels of wash vehicle underside.

Dented or bent rims cause tire pressure loss and damage to the tire beads. For this reason, check rims for damage at regular intervals.

The rim flanges must be checked for wear before a tire is mounted. Remove burrs, if there are any.

Observe wheel bolts!

- 1 For forged light alloy rims only
- 2 For steel rims only

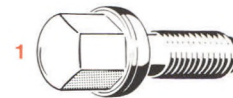

9103

Caution:

Do not use the long wheel bolts (1) intended for light alloy wheels only when mounting steel rims. Use only the shorter bolts (2) for the steel rims.

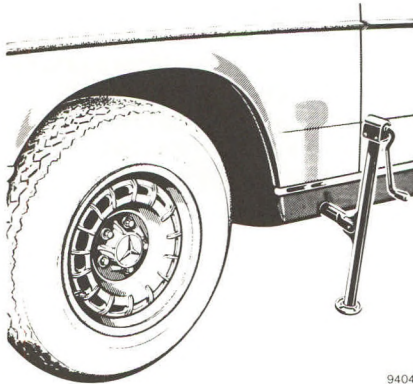

9404

Changing Wheels

1. Depress parking brake pedal.
2. Move selector lever to position "P".
3. Safeguard vehicle against rolling off by using chocks or similar. Place chocks under both opposite wheels (on downhill side), on a level road on both sides of the opposite front wheel when changing a rear wheel.
4. Using the combination wrench, loosen but do not yet remove the wheel bolts.
5. Clean jack supporting tube, if necessary. (Jack tubes are behind the front wheel housings and in front of the rear wheel housing.)
6. Insert jack arm into tube hole up to the stop. Position the jack so that it will always be vertical as seen from the side, even on inclines. Jack up the vehicle until the wheel is clear off the ground.
7. Then back out the wheel bolts. Protect bolt threads from dirt and sand. Remove the wheel.

Note:

- It must be ensured that light alloy rims are not dropped on their outside face since this may damage the plastic center hub cover.
8. Adjust the jack to allow the wheel to be slipped on without being lifted.
 9. Slip on wheel and press against wheel mounting flange. Turn in wheel bolts.

10. Lower car and remove jack. Tighten the five bolts evenly by going around the wheel and tightening every other bolt until all the bolts are tight. Observe a tightening torque of 10 mkp/72 lb-ft.
11. Correct tire pressure.

Tire pressure

A table (see fuel filler flap or last page) lists the tire inflation pressures specified for summer and winter tires as well as for the varying operating conditions.

Tire temperatures and pressure increase with the vehicle speed. Tire pressure should therefore only be corrected on cold tires. Correct tire pressure in hot tires only if pressure has dropped below the data listed in the table and the respective operating conditions are taken into consideration.

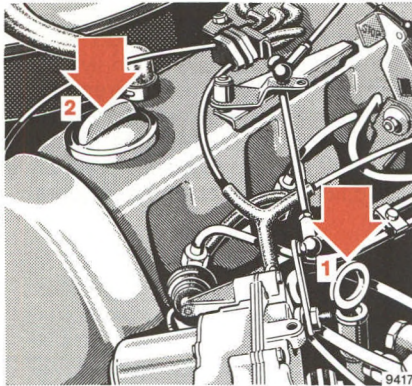

Engine Oil Level Check

- 1 Dipstick
- 2 Oil filler hole

Check engine oil level at regular intervals, after refueling, with the engine at operating temperature and shut off.



The vehicle should be parked on level ground and the oil level must be somewhere between the lower and the upper mark on dipstick (1); do not replenish in excess of the upper mark.

Wipe dipstick before any oil level measurement. To determine the oil level, check both sides of the dipstick. Always determine the oil level by means of the straight horizontal marking formed by the oil on one side of the dipstick.

For viscosity and capacity, see "Fuels, Coolants, Lubricants, etc., and last page".

Checking Coolant Level

The coolant level can be checked visually at the transparent coolant reservoir.

To check the coolant level, the vehicle must be parked on level ground.

The coolant level must reach:

The marking (1, arrow) on the reservoir when the engine is cold.

Approx. 2 cm/0.8 in higher when the engine is at operating temperature.

Replenishing Coolant

If a small amount of coolant has to be added (due to evaporation of water), plain water can be added.

If a larger quantity of coolant has to be added, a 50/50 mixture of water and antifreeze should be used.

Caution:

Do not remove pressure cap on coolant reservoir if engine temperature is above 90° C/194° F. Allow engine to cool down before removing cap. The coolant reservoir contains hot water and is under pressure.

First turn cap to first notch to relieve excess pressure using a rag. If opened immediately, hot scalding fluid and steam will be blown out under pressure.

The drain plugs for the cooling system are located on the right-hand side of the engine block and the bottom of the radiator.

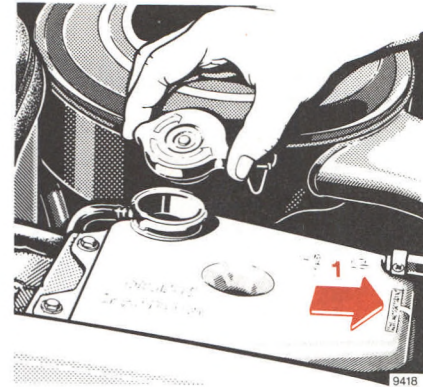

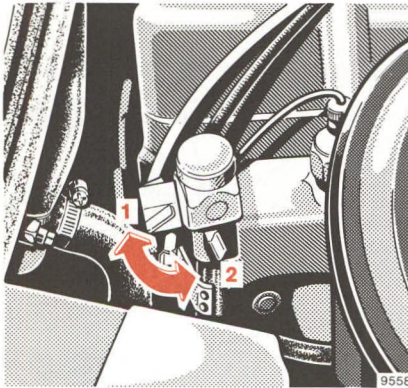

Fluid Level — Automatic Transmission

At regular intervals, check the fluid level of the automatic transmission together with the engine oil level prior to every long trip.

Check transmission fluid level with the engine idling, parking brake engaged and selector lever in position "P". The vehicle must be parked on level ground. Prior to the check, allow engine to idle for approx. 1 to 2 minutes.

Measure oil level with the dipstick completely inserted and the locking lever released (1).

Painstaking cleanliness must be observed!

To wipe the dipstick, use a clean, lintfree cloth (preferably leather).

To fill the transmission with fluid, only pour it through a fine-mesh filter into the dipstick opening. Even the slightest impurity may cause operational troubles.

The oil level in the transmission is dependent upon the oil temperature.

The maximum and minimum oil level marks on the dipstick are applicable references only if the transmission fluid has reached its normal operating temperature of 80° C/176° F.

If, however, the transmission fluid cools down to 20–30° C/68–86° F, which is the normal shop temperature range, then the maximum oil level will be approximately 5 mm/0.2 in below the minimum mark on the dipstick. We stress this point because an oil change is normally performed when the transmission oil has cooled down to shop temperature.

The fluid level must not exceed the dipstick maximum mark with the fluid at operating temperature. Drain or siphon off excess fluid, if required.

The push dipstick all the way in and swing locking lever downwards (2).

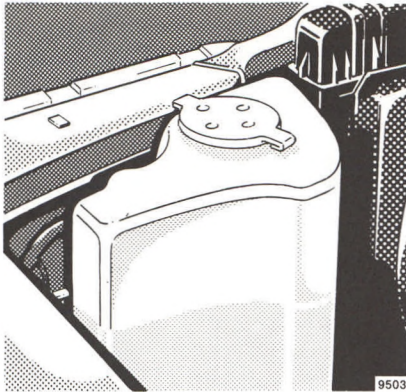

Reservoirs for Window Washing Systems

The reservoir for the windshield washing system is located in the engine compartment.

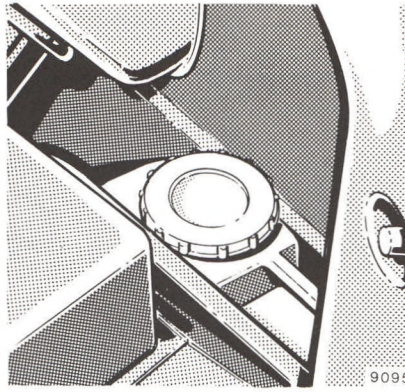

The reservoir for the rear window washing system is located behind the panel on the RH side in the cargo space.

To open the panel, pull handle and fold down panel.

Replenishing reservoir:
Replenish with water blended with windshield detergent. Test function of washing system.

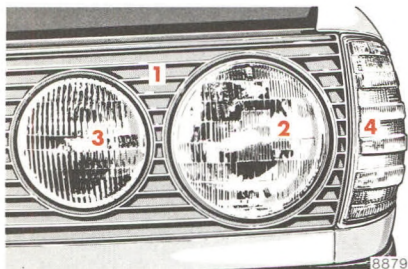

Replacing Bulbs

To remove, push the bulb in and turn to the left, then lift the bulb out.

To install, grip the bulb with a paper tissue or similar cloth, align the pins on the base of the bulb with the grooves in the bulb socket, push in lightly and turn to the right until the stop is felt.

Install only bulbs of prescribed wattage. Refer to "Technical Data and last page".

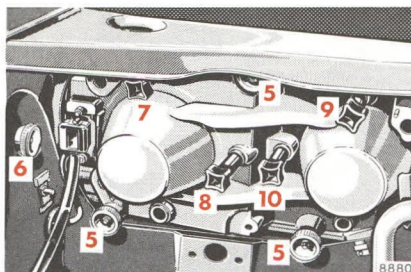

Headlamp Aiming

Correct headlamp aiming is of paramount importance to the roadworthiness of the car. Check and readjust headlamps at regular intervals and invariably when a lamp has been replaced.

Front Lamps

- 1 Cover. Remove cover (1) after backing out knurled plastic nuts located behind headlamps.
- 2 Sealed-beam unit for high and low beam

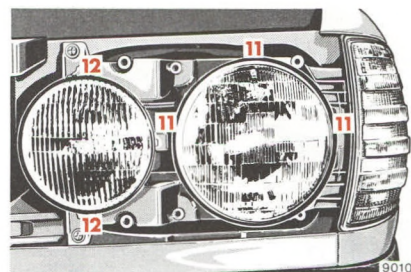

- 3 Fog lamp
- 4 Turn signal, parking, side marker and standing lamp
- 5 Securing nuts for cover
- 6 Securing nuts for turn signal, parking, side marker and standing lamp
- 7 Vertical aiming screw, sealed-beam unit
- 8 Horizontal aiming screw, sealed-beam unit
- 9 Vertical aiming screw, fog lamp
- 10 Horizontal aiming screw, fog lamp

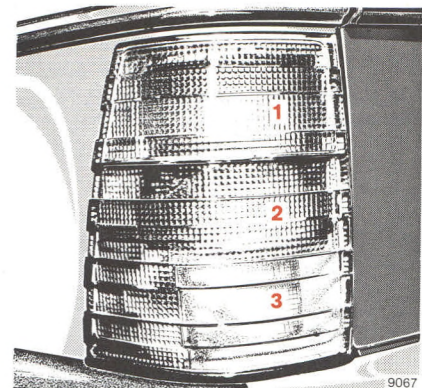
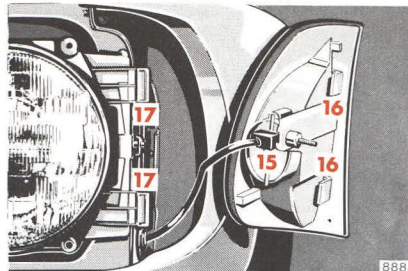
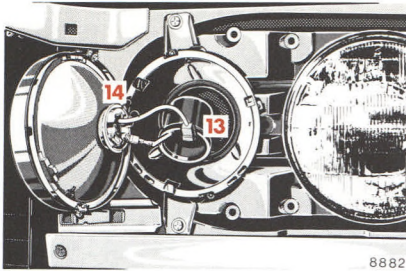

- 11 Securing screws for sealed-beam unit retaining ring. Loosen securing screws, remove retaining ring and unit. Pull off connector.
- 12 Securing screws for fog lamp retaining ring. Loosen securing screws and take out lamp body. Pull off plug (13). Disengage retaining spring and remove bulb (14).
- 15 Bulb for turn signal, parking, side marker and standing lamp. Loosen fastener (6). Push lamp body forward and detach. Hold lamp holder by the wide lug and

pull out. Depress bulb, turn to the left and take out. When installing the bulb holder, the lugs must engage the lamp body recesses. When installing the lamp body, never fail to engage the locating webs (16) between the retaining springs (17).

Tail Lamp Assemblies

- 1 Turn signal lamp
- 2 Stop lamp
- 3 Tail lamp, standing lamp, side marker lamp

Loosen both securing nuts in the cargo space but do not unscrew completely. Loosen tail lamp assembly by exerting even pressure on both nuts. Unscrew securing screws completely and detach tail lamp assembly. Push up the securing lug of the lamp holder slightly and remove lamp holder.

To replace, depress bulb, turn it to the left and pull it out.

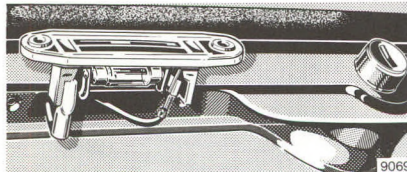
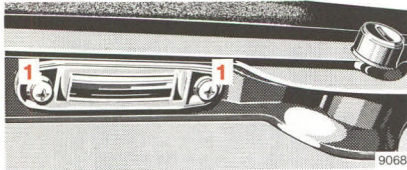

License Plate Lamps

Loosen both the securing screws (1) and take out lamp.

Backup Lamps

Loosen securing screws and detach lens. To replace, depress the bulb, turn it to the left and pull it out.

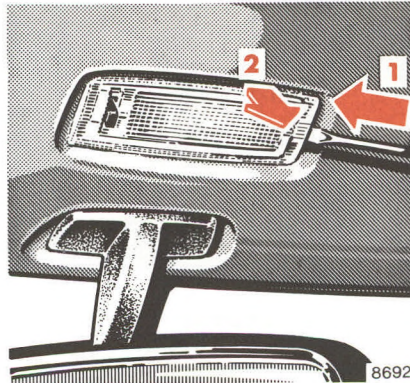

Courtesy Lamps

To replace the bulb, press courtesy lamp slightly towards the left (1), lift off at right-hand side (2) and pull out to the right.

The same applies when removing the rear courtesy lamp.

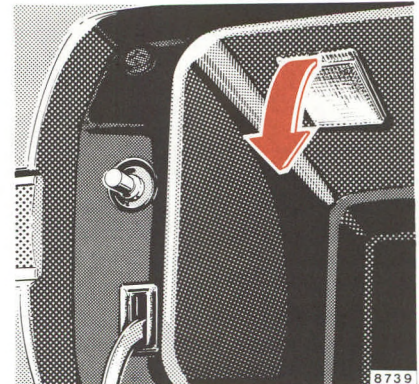

Glove Compartment Lamp

To replace the bulb, pull out lamp.

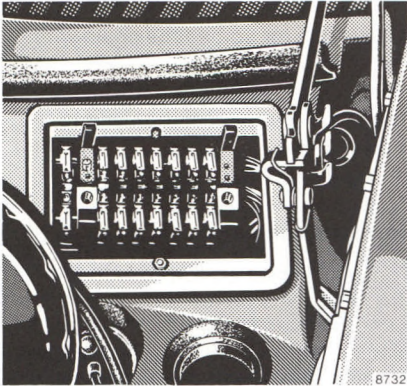

Fuses

The fuse box is located in the engine compartment.

A summary of the protected equipment is printed in the fuse box cover.

Fuse arrangement in the box — starting at engine side, proceeding from inside to outside —

upper row: odd numbers

1, 3, 5 etc. up to 13;

lower row: even numbers

2, 4, 6 etc. up to 14.

Fuses must be replaced, not repaired or bridged.

Spare fuses are stored in the fuse box (observe amperage and color code).

Determine the cause of a short prior to replacing a burned-out fuse.

After replacing a fuse, screw on the fuse box cover firmly.

Battery

Check the fluid level in the cells from outside approximately every 4 weeks, and more often in summer and in hot zones.

The fluid level must be between the lower and the upper markings.

Only replenish with distilled water. Do not use metal funnels and do not perforate the diaphragm of the battery overfill protection.

The battery is filled to the maximum level when the water level in the cell filling chamber stops going down.

If battery acid is to be extracted for battery diagnosis purposes, perforate the diaphragm with the hydrometer or the tube attached to it.

Coat battery terminal clamps with acidproof grease. Keep battery clean and dry.

Only tow vehicle with the battery connected.

Only charge battery with a battery charger when it is disconnected from the vehicle electrical circuit.

Note:

While the engine is running the battery terminal clamps must not be loosened or detached as otherwise the alternator and other electronic units would be damaged.

Tow-starting and Towing the Vehicle

Towing eyes are situated underneath the front and rear end on the RH side. Use a solid towing link such as a towbar.

Only tow-start vehicle with the battery connected and the key in steering lock position "2".

Caution: Remember, however, that until the engine is running, the power steering and power brakes do not offer assistance and considerable additional effort is required to steer and stop the car.

Emergency Engine Start (Tow-starting)

Shift selector lever to "N" and turn key in steering lock to position "2". Have vehicle towed. Having attained a speed of 30 km/h/18 mph — cold transmission — or 50 km/h/30 mph

— warm transmission — keep on driving at this speed for approximately 2 minutes to ensure sufficient fluid pressure in the transmission.

To crank the engine, shift selector lever to "S". Touch the accelerator only when the engine starts firing. As soon as the engine has started, immediately return selector lever to "N". It is important to allow the engine to idle for at least 1 minute before starting off because the preglowing process starts when the key is in steering lock position "2" and is not immediately disrupted after the engine has been tow-started. During this time the preglowing process is cut out automatically. If the engine has not fired after a few seconds, shift the selector lever from "S" to "N" to protect the transmission from damage.

For a new starting attempt, tow-start the vehicle for some time again with the selector lever in position "N" and repeat the starting procedure.

The same method can be used to start the engine in emergencies when rolling downhill.

Towing a Vehicle

The vehicle may be towed with the driving wheels on the ground and the selector lever in position "N" for distances up to 120 km / 75 miles and at a speed not to exceed 50 km/h / 30 mph.

To positively avoid a possibility of damage to the transmission, however, we recommend to disconnect the drive shaft at the rear axle drive flange on any towing beyond a short tow to a nearby garage.

Jump Starting

If the battery is discharged the engine can be started with jumper cables (minimum lead cross section is 35 mm²) and the (12 V) battery of another vehicle.

Proceed as follows:

- Turn key to steering lock position "0".
- Run engine of jumper vehicle at high idle.
- First connect jumper cables to the positive battery terminals and then to the negative terminals.

- Start engine as normal.
- After the engine has started, first remove jumper cables from the negative battery terminals and then from the positive terminals.

Instructions:

A discharged battery can freeze at approx. $-10^{\circ}\text{C} / +14^{\circ}\text{F}$. In all cases it must be thawed out before jumper leads are used.

Never lean over batteries while jump starting, you might get burned.

Unlocking of the Filler Flap

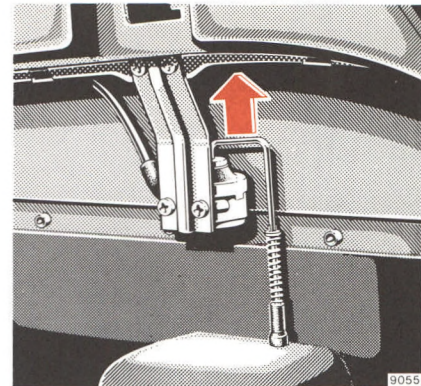

If the fuel filler flap cannot be opened in a vehicle locked with the master lock system, pull handle in panel and fold down panel. Then pull up the linkage rod of the lock element.

Technical Data
Fuels Coolants
Lubricants etc.



Identification Plates

When ordering spare parts, please quote chassis and engine numbers.



9407

- 1 Certification Tag
(left door pillar)
- 2 Identification Tag
(left window post)

- 3 Chassis No.
- 4 Engine No.
- 5 Body No. and Paintwork No.

- 6 Information Tag
California version
Vacuum line routing
for emission control system
- 7 Emission Control Tag
- 8 Emission Control Tag
Catalyst Information

Vehicle Data Cards

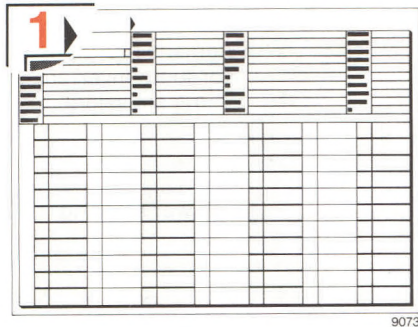

The vehicle data cards bear all the important data relating to your vehicle.

Data card No. 1 bears the key number and should on no account be left in the vehicle. Submit this card to your MERCEDES-BENZ service station to request a replacement key in case of loss.

Data card No. 2 bears no key data and is kept in the maintenance booklet. Presenting this card to the service station will facilitate the processing of the order.

Warranty Coverage

Your car is covered under the terms of the “warranties” printed in the owner’s service and warranty policy booklet and your dealer will exchange or repair any defective parts in accordance with the terms of the following warranties:

1. New vehicle limited warranty
2. Emission systems warranty
3. Emission performance warranty
4. California emission control systems warranty (state of California only unless purchased optionally for diesel models)

Loss of owner’s service and warranty policy

Should you lose your owner’s service and warranty policy booklet, have your local MB dealer arrange for a replacement. It will be mailed to you.

Technical Data

Type..... 300 TD-TURBO DIESEL
(123.193)¹

Engine

Engine type..... 617.952
 Work cycle..... Diesel four stroke
 No. of cylinders..... 5
 Bore..... 90.9 mm/3.58 in
 Stroke..... 92.4 mm/3.64 in
 Total piston displacement.... 2998 cm³/183.0 in³
 Compression ratio..... 21.5
 Output acc. to SAE..... 89 net-kW/4350 rpm/
 120 net-bhp/4350 rpm
 Valve clearance } Intake... 0.10 mm/0.004 in
 (cold engine) } Exhaust . 0.35 mm/0.014 in
 Injection order..... 1-2-4-5-3

V-belts:

Water pump — fan — alter-
 nator: 2 V-belts..... 9.5 × 1035 mm
 Power steering..... 12.5 × 1145 mm
 Air conditioning..... 12.5 × 925 mm

Transmission

Design..... Automatic four-speed
torque-converter
transmission

Steering System

Design..... Power steering

Rims — Tires

Rims..... 6 J × 14 H 2
 Summer tires:
 Radial-ply tires..... 195/70 SR 14
 Winter tires:
 Radial-ply tires..... 195/70 SR 14 M + S

Electrical System

Alternator..... 14 V / 55 A
 Starter motor..... 12 V / 2.3 kW
 Battery..... 12 V / 90 Ah

¹ The quoted data apply only to the standard vehicle. See a MERCEDES-BENZ service station for the corresponding data of all special bodies and special equipment.

Bulbs	12 V
High and low beams	Sealed beam/ Halogen
Fog lamps	H 3
Turn signal, clearance and side marker lamps, front	21/5 W/32/3 cp
Stop lamps	21 W/32 cp
Turn signal lamps, rear	21 W/32 cp
Tail, standing and side marker lamps, rear	10 W/ 6 cp
Backup lamps	21 W/32 cp
License plate lamps	5 W festoon lamp
Interior lamps	10 W festoon lamp
Glove compartment lamp	5 W festoon lamp

Main Dimensions	
Overall vehicle length	4848 mm/190.9 in
Overall vehicle width	1786 mm/ 70.3 in
Overall height (curb condition)	1470 mm/ 57.9 in
Wheel base	2795 mm/110.0 in
Track, front	1488 mm/ 58.6 in
Track, rear	1453 mm/ 57.2 in

Weights See certification tag

Fuels Coolants Lubricants etc. Capacities

Vehicle components and their respective lubricants must match.

Therefore use only brands tested and recommended by us.

Enquire at your MERCEDES-BENZ service station.

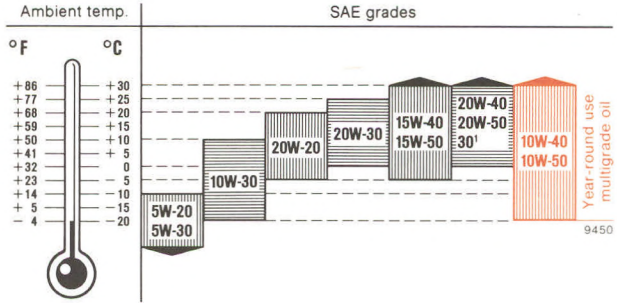
	Capacity	Fuels, coolants, lubricants, etc.
Total oil capacity in case of engine oil and filter change	7.5 l/7.9 US qt	<p>Recommended engine oil</p>  <p>Ambient temp. SAE grades</p> <p>°F °C</p> <p>9450</p>
Automatic transmission	Initial fill: 7.3 l/7.7 US qt Fluid change: 6.2 l/6.5 US qt	Automatic transmission fluid (ATF)
Rear axle	1.0 l/1.0 US qt	Hypoid gear oil SAE 90, 85 W 90

¹ SAE 40 may be used if ambient temperatures constantly exceed +30° C/ +86° F.

	Capacity	Fuels, coolants, lubricants, etc.
Level control	3.5 l/3.7 US qt	Hydraulic oil
Accelerator control linkage		Hydraulic fluid
Power steering	1.4 l/1.5 US qt	Automatic transmission fluid (ATF)
Front wheel hubs	approx. 60 g each/2.1 oz each	Multipurpose grease
Grease nipples		Multipurpose or lubrication grease
Door locks		Special grease
Battery terminals		Bosch special grease
Brake reservoir	approx. 0.5 l/0.5 US qt	Brake fluid
Windshield washer system	approximately 3.0 l/3.2 US qt	Water plus windshield detergent
Rear window washer system	approximately 2.5 l/2.6 US qt	
Fuel tank including a reserve of	approximately 70 l/18.5 US gal approximately 11 l/2.9 US gal	Diesel fuels acc. to ASTM D 975 grades 1 and 2 as well as VV-F-800 a grades 1 and 2
Cooling system	12.5 l/13.2 US qt	Coolant



Engine Oils

Engine oils are specifically tested for their suitability in our engines. Therefore, use only engine oils recommended by us. Information on recommended brands is available at any MERCEDES-BENZ service station.

A new or reconditioned engine is filled with an initial operation oil in

the factory or in a MERCEDES-BENZ service station. This oil is specially developed for the specific operating conditions during the first 1300 – 1600 km/800 – 1000 miles. A recommended engine oil may be used for topping up if the oil level drops of the dipstick minimum mark prior to the first service 1300 – 1600 km/800 – 1000 miles.

Brake Fluid

Brake fluid should be changed once a year, preferably in spring. Only use brake fluid recommended by us. For further information, refer to "Safe Driving".

Diesel Fuels

Use only commercially available vehicular diesel fuels No. 2 or No. 1 (ASTM D 975 No. 2-D or No. 1-D).

Change engine oil in compliance with section "Engine Oil Change and Oil Filter Service" if diesel fuels are used whose sulphur content exceeds 0.5 % by weight. Marine diesel fuel, heating oil or the like must not be used.

At very low temperatures the fluidity of No. 2-D diesel fuel may become insufficient due to paraffin separation. To avoid malfunctions, No. 2-D diesel fuel of a lowered cloud point are marketed during the cold season.

At temperatures below 0° C/ + 32° F use winterized or No. 1 diesel fuel only. If not available, certain quantity of kerosene may be added. Mixing only to be done within the cars' fuel tank. Kerosene has to be filled in before the diesel fuel.

Engine power may drop according to the proportion of kerosene. For this reason, keep percentage of kerosene added to the minimum necessitated by the ambient temperature.

The following table can be used as a reference, if adding of kerosene becomes necessary. The mixing ra-

tios shown refer to the total mixture. We recommend not to exceed the mixture ratio, dependent on prevailing temperatures by max. 50 %.

Adding of kerosene to No. 1-D diesel fuel is not recommended even at low temperatures. The use of further additives is not recommended.

Ambient temperature	No. 2 Diesel fuel %	Kerosene %
0° C to - 10° C/ + 32° F to + 14° F	70	30
below - 10° C/ + 14° F	50	50

Coolants

The coolant is a mixture of water and antifreeze. In production, the cooling system is filled with an antifreeze-water mixture offering protection to approx. $-30^{\circ}\text{C}/-22^{\circ}\text{F}$. The red mark on the temperature gauge in the instrument cluster is matched to this antifreeze-water mixture (approx. boiling point $125^{\circ}\text{C}/257^{\circ}\text{F}$). The protection against corrosion is also ensured by this mixture making it unnecessary to add a corrosion inhibitor.

The coolant remains in the cooling system all year long and must be renewed after 3 years at the latest. If coolant is lost, replace missing quantity with water (potable water quality) plus antifreeze of a recommended brand.

For reasons of corrosion inhibition the minimum proportion of antifreeze must be 34 %, which gives antifreeze protection down to $-20^{\circ}\text{C}/-4^{\circ}\text{F}$.

If antifreeze is not available, add a corrosion inhibitor to the cooling water to ensure proper protection against corrosion. To treat the cooling water, do not use more than 1 % (10 cm³/l) of a recommended corrosion inhibitor.

Without antifreeze in the cooling system, the water already starts boiling at approx. $118^{\circ}\text{C}/224^{\circ}\text{F}$, which means that the pointer of the temperature gauge in the instrument cluster may still be below the red mark.

Antifreeze

Your vehicle contains a number of aluminum parts. The use of aluminum components in motor vehicle engines necessitates that antifreeze/coolant used in such engines be specifically formulated to protect the aluminum parts. (Failure to use such antifreeze/coolant may result in a significantly shortened service life.)

While there may be a number of antifreeze/coolants available which will provide the requisite protection, all such products have not been tested for MERCEDES-BENZ vehicles.

The following products, however, are deemed suitable for use in your car: MERCEDES-BENZ Anti-Freeze and Summer Coolant.

Prior to the onset of the cold season, check the coolant for sufficient protection to prevent freezing. Repeat this check during the cold spell. Regular testing of the antifreeze concentration is carried out only at each MERCEDES-BENZ maintenance service.

Protection up to	Antifreeze
-20°C } -4°F }	4.50 l/4.8 US qt
-30°C } -22°F }	5.50 l/5.8 US qt
-40°C } -40°F }	6.50 l/6.9 US qt

Customers who are interested in ordering service literature for their vehicles are advised to contact our subsidiaries in the U.S. or Canada at the following addresses, respectively

for U.S.A.: Mercedes-Benz of N.A. Inc.
One Mercedes Drive
P.O. Box 350
Montvale, New Jersey 07645
Att: Technical Publications
Tel: (201) 573-0600

for Canada: Mercedes-Benz of Canada
849 Eglinton Ave., East
Toronto 17, Ont., Canada
Att: Service Department
Tel: 416-425-3550

The above companies will be happy to handle any such requests from customers.

We consider this to be the best way in obtaining accurate information for your vehicle.

Printed in Germany

We reserve the right to modify the technical details of the vehicle as given in the data and illustrations of this Owner's Manual (s.e.e.o.). Reprinting, translation and copying, even of excerpts, is not permitted without our prior authorization in writing.

ZKD/VII.81.5/PVL

- **Fuel:** Diesel fuels acc. to ASTM D 975, grades 1 and 2 as well as VV-F-800 a grades 1 and 2. Fuel tank capacity approx. 70 l/18.5 US gal, this includes approx. 11 l/2.9 US gal reserve. Only fill fuel tank until the discharge nozzle unit cuts out — do not over fill.
- **Engine Oil:** Check engine oil level regularly and prior to every long trip. See page 72. Quantity differential between upper and lower dipstick marking level: 1,5 l/1.6 US qt. Year-round multigrade oils 10 W-40/10 W-50. For further information, refer to page 88.
- **Automatic Transmission:** Automatic transmission fluid (ATF). For level checks and replenishment, refer to page 74.
- **Coolant:** For normal replenishment, use water (potable water quality). For further information (e.g. antifreeze), refer to page 92.
- **Bulbs:** High and low beams: Sealed beam/Halogen, tail and standing lamps 10 W/6 cp, turn signal, clearance and side marker lamps, front 21/5 W/32/3 cp, turn signal lamps, rear 21 W/32 cp, stop lamps 21 W/32 cp. For further information, refer to "Technical Data".
- **Tire Pressure:** For driving up to 160 km/h/100 mph

Cold tires:

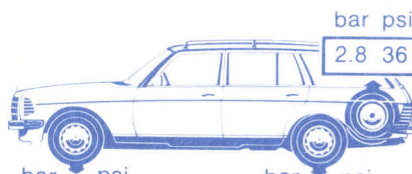

Partial load:
Maximum load:

bar	psi
2.0	28
2.0	28

bar	psi
2.2	32
2.7	36

Warm tires:

Pressure may rise by up to +0.5 bar/+8 psi.
Never release any air!

For driving above 160 km/h/100 mph
+0.3 bar/+4 psi



Mercedes-Benz
service

Daimler-Benz AG Stuttgart-Untertuerkheim Zentralkundendienst
123 584 24 82 Bestell-Nr. 6550529613 USA-Ausgabe A 1982

