

Owner's
Manual

280 E
280 CE

Mercedes-Benz

1981

1981



24

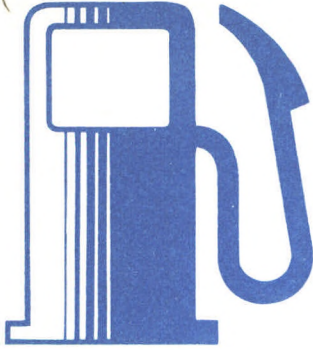

Drive Sensibly—Save Fuel

Fuel consumption depends to a great extent on driving habits and operating conditions.

In order to save fuel you should:

- ensure that tire pressures are correct
- not carry unnecessary loads
- remove ski racks or roof-mounted luggage racks when not in use
- not warm up your engine at idle and with the vehicle at standstill
- avoid frequent acceleration and deceleration
- avoid frequent braking
- avoid unnecessarily high speeds
- have all the maintenance jobs specified by us carried out at regular intervals by a MERCEDES-BENZ service station

Driving in low temperature weather, in stop-and-go city traffic and on short hops, and in hilly country also increases fuel consumption.

280 E
280 CE

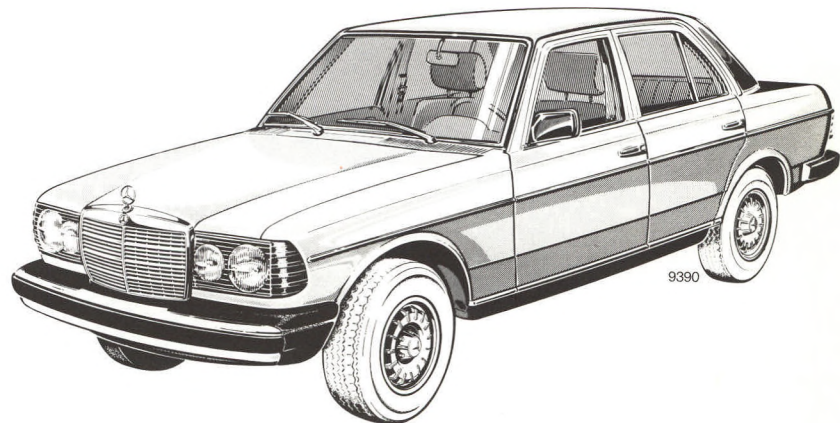

Type 123
1981

You have chosen to drive a MERCEDES-BENZ, a car in whose construction and production we have taken great pains because we believe that quality is not a matter of chance.

Perhaps you have already had experience with a MERCEDES, maybe this is your first car from the DAIMLER-BENZ company. In both cases – for your own benefit – please read this owner's manual before putting it away. Even though you have been driving a car for years, some things in this car may be new to you, and this manual certainly contains a few hints which will help you to make the most of your new car.

We wish you safe and pleasant motoring.
DAIMLER-BENZ Aktiengesellschaft

Contents

This Owner's Manual also describes optional extras as far as an introduction on their handling is required. As these extras need to be ordered separately, the equipment of your vehicle may deviate from the descriptions and illustrations to some extent.

The last page

What you should know at the gas station

Vehicle Operation

Instruments and Controls	8
Instrument Cluster	10
Keys, Doors	12
Master and Supplementary Key	12
Opening, Locking and Unlocking of Doors	12
Master Lock System	13
Seats	14
Adjustment of Driver's Seat and Front Passenger Seat	14
Seat Heater	15
Safety Headrests	15
Arm Rest (Rear Seat)	16
Safety Belts	16
Controls	18
Steering Lock	18
Lighting Switch	19
Combination Switch	20
Cruise Control	21
Various Equipment	22
Interior Lamps	22
Outside Rear View Mirror	22
Inside Rear View Mirror	22
Sun Visor	23
Heated Rear Window	23
Shelf below Rear Window	23
Electric Lighter	24
Sliding Roof	24
Electric Window Lifters	25

Automatic Climate Control	26
Radio	28

Driving

Hood	32
Regular Inspections	33
Parking Brake	34
Catalytic Converter Cautions	35
Starting and Turning off the Engine	36
Starting and Shifting Gears	37
Safe Driving	39
Brake Pad Wear Indicator Lamp	41
Brake Fluid	41
Charge Indicator Lamp	41
Oil Pressure Gauge	41
Coolant Temperature Gauge	41
Emission Control	42
Engine Oil Consumption	42
The First 1500 km/1000 Miles	42
Special Operating Conditions	43
Winter Driving	43
Hints for Driving	43
Tire Chains	44
Traveling Abroad	44

Vehicle Care

MERCEDES-BENZ Maintenance System 46
 Severe Operating Conditions . 46
 Engine Oil Change and Filter Change 46
 Automatic Transmission – Fluid and Filter Change 46
 Spare Parts Service 47
 Cleaning and Care of the Vehicle Jobs related to Care 49

Practical Hints

Ash trays 52
 Rear Seat Cushion 52
 First Aid Kit 53
 Luggage or Ski Racks 53
 Spare Wheel, Jack, Vehicle Tool Kit 53
 Wheels, Tires, Changing Wheels
 Wheels, Tires 54
 Changing Wheels 55
 Tire Pressure 56
 Checking Fuels, Coolants, Lubricants, etc. 57
 Engine Oil Level Check 57
 Replenishing Coolant 58
 Fluid Level – Automatic Transmission 59

Electrical System 60
 Replacing Bulbs 60
 Fuses 64
 Battery 64
 Spark Plugs 64
 Emergency Operating of Sliding Roof 65
 Unlocking of the Fuel Tank Filler Flap 65
 Emergency-starting and Towing the Vehicle 66
 Jump Starting 67

Technical Data – Fuels, Coolants, Lubricants, etc.

Identification Plates 70
 Vehicle Data Cards 71
 Technical Data 72
 Fuels, Coolants, Lubricants, etc.
 Capacities 74
 Engine Oils 76
 Brake Fluid 76
 Coolants 77
 Service-Literature 78

Vehicle Operation



Driving



Vehicle Care



Practical Hints



Technical Data – Fuels, Coolants, Lubricants, etc.



Vehicle Operation

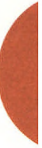

Instruments and Controls

For more detailed descriptions see quoted pages.

- 1 Speaker grilles
- 2 Swivelling side ventilation outlets (page 26)
- 3 Parking brake release knob (page 34)
- 4 Hood lock release handle (page 32)
- 5 Parking brake pedal (page 34)
- 6 Combination switch (page 20)
- 7 Lighting switch (page 19)
- 8 Cruise control (page 21)
- 9 Instrument cluster (page 10)
- 10 Horn control
- 11 Steering lock with ignition/starter switch (page 18)
- 12 Swivelling outlets for cooled air (page 26)
- 13 Switch for rear courtesy lamp
- 14 Switch for automatic antenna (page 29)
- 15 Switch for electric sliding roof (page 24)
- 16 Switch for heated rear window (page 23)
- 17 Automatic climate control (page 26)
- 18 Radio (page 28)
- 19 Ash tray with electric lighter (page 24, 52)
- 20 Switch for left front seat heater (page 15)
- 21 Switch for right front seat heater (page 15)
- 22 Speaker – fader control (page 29)
- 23 Switch group for window lifters (page 25)
- 24 Hazard warning flasher switch
Push switch = hazard warning flasher system switched on
Push switch once more = hazard warning flasher system switched off
- 25 Glove compartment, illuminated (only if steering lock is in position “1” or “2”)
To open, move handle sideways

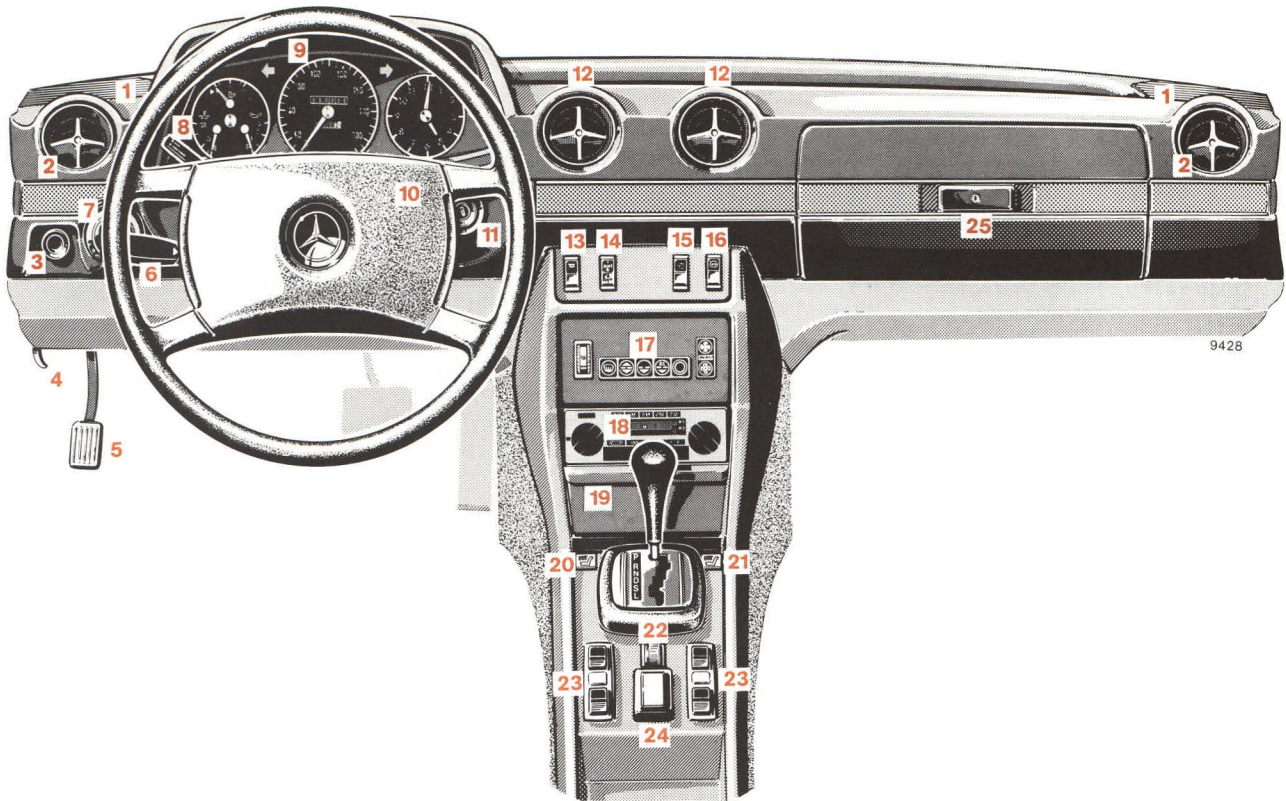

Instrument Cluster

- 1 Coolant temperature gauge (°C)
Up to red marking: Maximum permissible temperature for an antifreeze-blended fill protecting down to $-30^{\circ}\text{C}/-22^{\circ}\text{F}$. See page 41
- 2 Fuel gauge with reserve warning lamp (yellow)
Fuel reserve for approx. 40 km/25 miles
For capacity, refer to page 75 and last page
- 3 Oil pressure gauge (bar). See page 41
- 4 Turn signal indicator lamp, left (green)
- 5 Main odometer
- 6 Trip odometer
- 7 Turn signal indicator lamp, right (green)
- 8 Electric clock
- 9 O₂-Sensor replacement indicator lamp (red):
When the indicator lamp comes on, the O₂-Sensor must be replaced
- 10 Seat belt warning lamp (red)
- 11 Knob for clock adjustment
(press in for adjustments)
- 12 Knob for instrument lamps and trip odometer
Rotate knob: instrument lamps are infinitely variable
Depress knob: trip odometer is turned back
- 13 Brake warning lamp (red) comes on if
 - the parking brake is engaged
 - too little brake fluid is in the reservoir
- 14 Brake pad wear indicator lamp (yellow):
Lamp comes on while braking and driving if the front wheel brake pads are worn down.
Refer to page 41
- 15 Charge indicator lamp (red):
Comes on when the steering lock key is moved to driving position "2" and must go out when the engine is idling. See page 41
- 16 High beam indicator lamp (blue)

Note

A stop is provided on the speedometer at the 138 km/h/85 mph reading. Speeds in excess of 138 km/h/85 mph will no longer be recorded.

Instrument Cluster

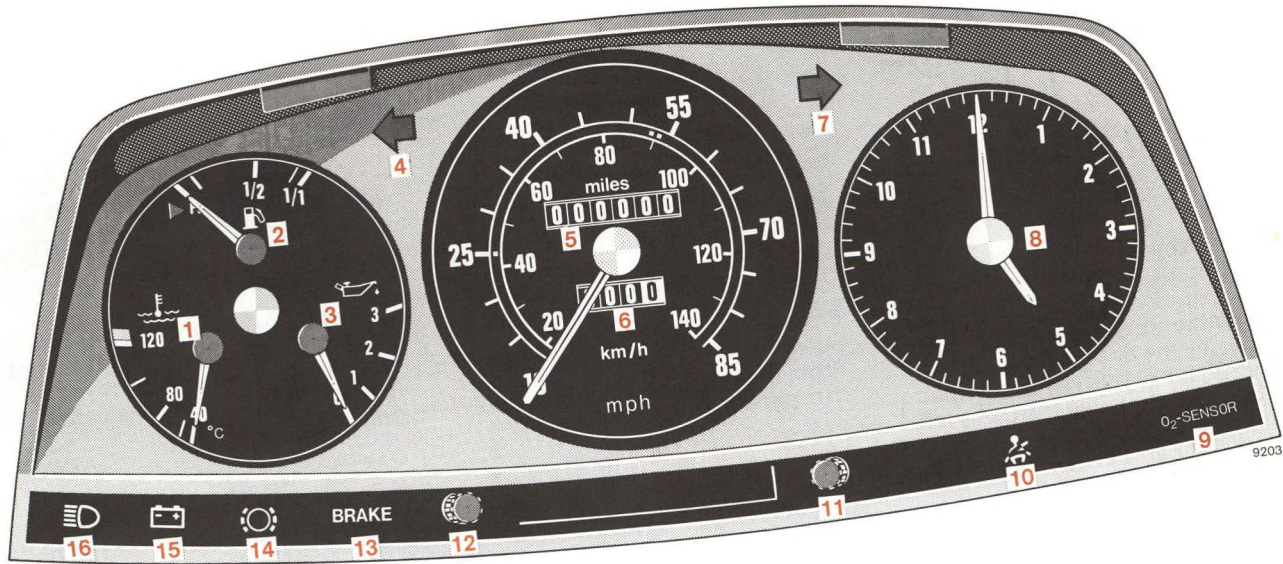

9203

Keys Doors

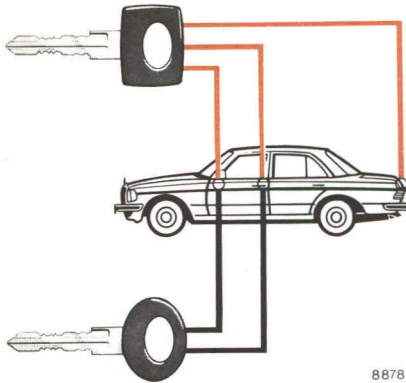

Master Key – square head – fits all locks on the car.

Supplementary Key – rounded head – fits only the door locks and the steering lock. This key is intended to be used whenever the car is left with an attendant. Be sure to lock glove compartment and trunk with the master key.

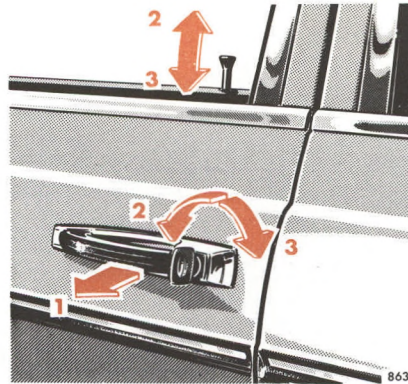

Opening the Doors

From outside: pull handle outwards (1).

From the inside: pull handle in door trim panel.

Locking and Unlocking of Doors

From the outside: turn key.

From the inside: actuate safety plunger (sedan) or safety lever (coupé).

- 2 Unlocking
- 3 Locking

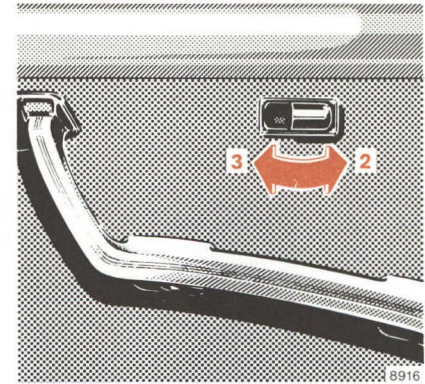

When the rear door plungers are pushed down the rear doors cannot be opened from the outside or the inside. They can be opened after pulling plungers up.

One cannot lock:

- the driver's door if it is open.
- any door if the door lock has not engaged fully. In this case open the door and close it again.

Master Lock System

The master lock system simultaneously locks or unlocks together with the driver's door all other doors, fuel tank filler flap and trunk lid. As the driver's door plunger is moved, the plungers of all other doors must move at the same time. If this is not the case, the lock of the corresponding door has not engaged fully. Open the door once more and close it correctly.

When the master lock system has been applied, the lock plungers of the front passenger door and the rear doors can also be operated manually from inside. In addition to this, the front passenger door can be locked or unlocked by means of the key.

The master lock system can only be applied by depressing the plunger on the driver's door. Lock plungers of the other doors cannot be depressed individually.

The trunk lid can also be unlocked separately by turning master key counterclockwise to the stop. Push the trunk lock button in with it and lift the lid. Return the key to its initial position and withdraw it. To lock the lid, close it firmly. It will then be locked again by the master lock system.

A provision has been made to facilitate permanent locking of the trunk lid for positive prevention of access to trunk by unauthorized persons.

Before leaving vehicle with an attendant, lock trunk with master key (square head) by turning key clockwise to stop (tumbler slot vertical), then provide attendant with round-headed supplementary key. Thus, the trunk lock has been excluded from the operation of the master lock system and cannot be opened except with the square-headed master key.

To reverse this, turn trunk lock counterclockwise back to horizontal position of the tumbler slot with master key. Lock will then be reengaged in master lock system; that is, it will automatically be locked or unlocked depending on whether the driver's door is locked or unlocked.

The master lock system operates on vacuum generated by the engine. A reservoir allows the master lock system to be actuated about five times after the engine is turned off. If the system can then no longer be engaged, idle engine for a short period.

If no vacuum is available, the locks can be actuated individually in the normal manner. The fuel tank filler flap, however, remains unlocked.

Note:

If the filler flap cannot be opened when the master lock system is unlocked, refer to "Unlocking of the Fuel Tank Filler Flap" (page 65).



Adjustment of Driver's Seat and Front Passenger Seat

Forward and backward adjustment: lift handle (1); slide seat to desired position and allow handle to re-engage.

Height of seat: raise lever (2); to raise seat, move seat forward; to lower seat, move seat backward; allow lever to reengage.

Seat back position: turn handwheel (3) forward or backward.

For full reclining of backrest, seat should be moved to one of the

forwardmost positions and headrest removed. For driving, return backrest to upright position and push seat back. Replace headrest.

Note:

Prior to operating the vehicle, the driver should adjust the seat height for proper vision as well as fore-aft placement and seat back angle to insure adequate control, reach, operation, and comfort. The headrest should also be adjusted for proper height so that when the cushion is tipped completely forward, it should form a cradle behind the seat occupant's head. Both the inside and outside rear view mirrors should then be adjusted for adequate rearward vision. Fasten seat belts. Children under the age of six or under the weight of 23 kg/50 lb should be seated in the back seat with an approved restraint system properly secured.

All seat, headrest, and rear view mirror adjustments as well as fastening of seat belts should be accomplished before the vehicle is put into motion.

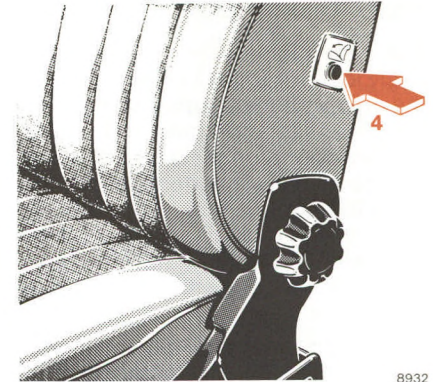

Coupé: When the doors are closed the backrests are locked by means of vacuum. The locks can be released by pushing button (4). When the doors are opened the backrests can be folded forward readily.

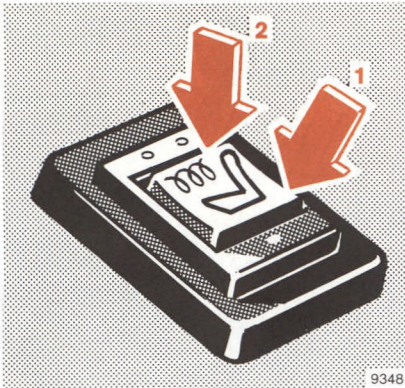

9348

Seat Heater

The seat heater can be switched on with the steering lock in positions "1" or "2".

Pushbutton center position
= seat heater switched off

Pushbutton position 1
= continuous operation

Pushbutton position 2
= quick heating

An indicator lamp in the switch comes on when the seat heater is switched on.

To save the battery, position 2 should not be switched on any longer than absolutely necessary if the engine is switched off.

Safety Headrests

Adjust headrest to support the back of the head approximately at ear level.

Safety headrests, front

Height adjustment:

Press headrest slightly forward (1) and reset upward or downward as required.

Detaching headrests:

Pull headrest out to the stop. Release arrester by depressing release knob to be felt under the covering material in rear of back rest and pull headrest upward quickly, holding it by the LH headrest post (viewed in driving direction). Finally, pull out head rest completely with both hands.

The headrest release knob is located below the LH headrest post (2).

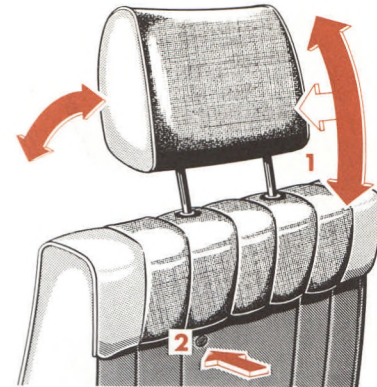

9277

Safety headrests, rear

Height adjustment:

Press headrest slightly forward and reset upward or downward as required.

Detaching headrests:

Pull up headrest until resistance can be felt. Then pull it out quickly using both hands.



Arm Rest (Rear Seat)

A center arm rest is provided in the rear seat which can be pulled out with a loop. When replacing, lift at the rear. For the removal of the rear seat cushion see "Practical Hints".

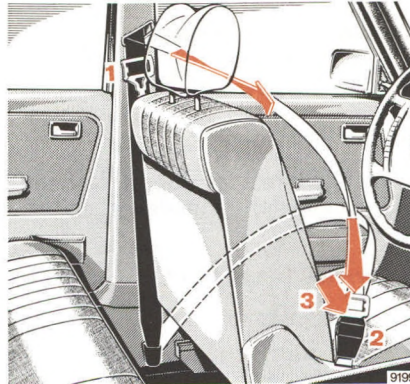

Safety Belts

Warning system:

The indicator is illuminated for 4–8 seconds after turning the steering lock key to position "2". If the safety belt of the driver's seat is not fastened a warning buzzer sounds simultaneously.

Fastening:

- Pull belt with latch plate (1) across shoulder and lap. The belt must not be twisted and must be tight.

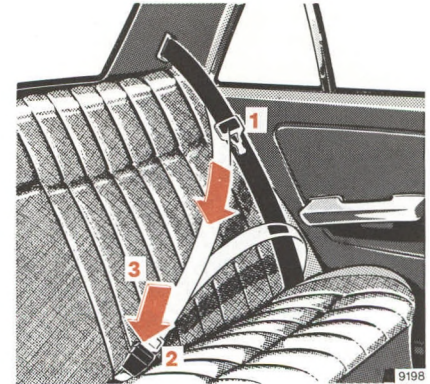

- Press latch plate (1) into buckle (2) and allow to engage audibly.

Unfastening:

- Depress red button (3) in buckle (2).
- Return latch plate (1) to initial position.

Operation:

The safety belt inertia reel stops the belt from unwinding further in case of vehicle deceleration in any direction or if the belt is pulled out quickly.

Functional test:

The locking function of the inertia reel can be tested by braking, driving around a bend or by pulling the belt out quickly.

Lap Belt in the Rear:

To fasten the lap belt, pull belt end across your lap and insert the latch

plate in the buckle. The belt must not be twisted and must be tight.

To shorten the belt, pull the loose belt end. To lengthen the belt, turn latch plate so that it is at right angles to the belt webbing and pull the belt.

Note:

No safety belt can be used for more than one person. Belts are not intended for children.

After an accident, inspect the safety belts and replace them, if required.

The belt anchors in the vehicle should also be checked.

Belt webbing must not be routed via sharp edges.

No modifications which may affect the efficiency of the belts must be made.

For cleaning and care of belt webbing, refer to page 49.

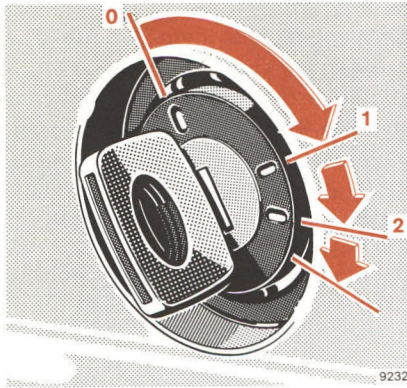

Steering Lock

- 0 Steering is locked when the key is withdrawn and the steering lock is engaged. The key can be withdrawn only in zero position.

Note:

Do not remove key from steering lock while the vehicle is in motion as this will cause the engagement of the steering lock thus rendering the vehicle inoperable.

- 1 Steering is unlocked. (If necessary, move steering wheel slight-

ly to turn the key clockwise to position "1".)

- 2 Driving.

Starting position:

Continue turning key clockwise to the stop. The starter is engaged when the key is pressed against the stop. The starter non-repeat unit requires the key to be returned to position "0" prior to a new starting attempt.

For starting and turning off the engine, refer to page 36.

Notes:

The following items can be operated with the key in steering lock position "1":

Wipers, windshield washer, headlamp flasher, electric lighter, glove compartment lamp, radio, electric seat heater.

The power supply to the standing lamps is disrupted if the key in the steering lock is in position "2".

A warning buzzer sounds when the key has been left in steering lock positions "1" or "0" and the driver's door is opened.

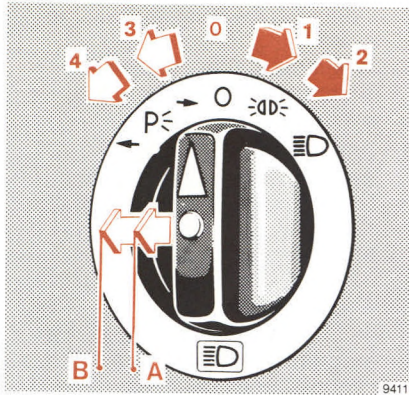

Lighting Switch

- 0 Off-position
- 1 Parking lamps (includes side marker lamps, tail lamps, license plate lamps, instrument panel lamps)
- 2 Same as pos. 1 plus headlamps

- 3 Standing lamps, right
- 4 Standing lamps, left
- A Turn to position 2 and pull out to first detent = same as position 2 plus fog lamps
- B Available for an option

Note:

With the steering lock key removed and the driver's door open a signal sounds if the vehicle's exterior lamps are not switched off (standing lamps excepted).

Controls

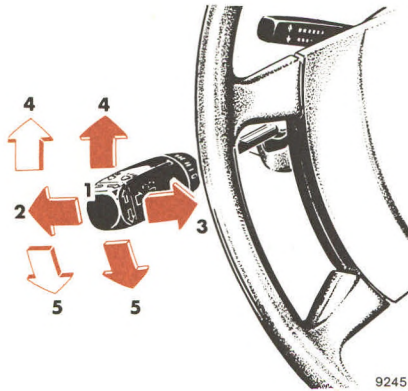

Combination Switch

- 1 Low beam (turn lighting switch clockwise two notches)
- 2 High beam (turn lighting switch clockwise two notches)
- 3 Headlamp flasher (high beam available independent of lighting switch position)
- 4 Turn signals, right
- 5 Turn signals, left



- 6 Control for windshield washer system
When the washer system is switched on, the wipers also operate
- 7 Windshield wiper control
0 Windshield wiper switched off
I Intermittent wiping
II Normal wiper speed
III High wiper speed

Hints:

If one of the turn signals fails, the turn signal indicator system flashes and sounds at a faster sequence than under normal operating conditions.

Fog lamps will only operate together with low beam headlamps. Fog lamps are turned off automatically when lighting switch is returned to off-position.

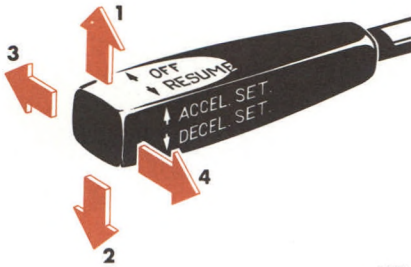

8623

Cruise Control

Any given speed above approximately 40 km/h/25 mph can be maintained with the cruise control by operating the switch.

- 1 = Setting (touch switch)
Accelerating (hold switch)
- 2 = Setting (touch switch)
Decelerating (hold switch)
Normally the vehicle is accelerated to the desired speed with the accelerator. Speed is set by briefly pushing the switch to position "1" or "2", and the accelerator can be released.

The speed can be increased (e. g. for passing) by using the accelerator. As soon as the accelerator is released, the previously set speed will be resumed automatically.

If a set speed is to be increased or decreased slightly, e. g. to adapt to the traffic flow, retain switch in position "1" or "2" until the desired speed is reached. When the switch is released, the newly set speed remains.

- 3 = Cancelling
To cancel the cruise control, briefly push lever to position "3".

The cruise control will also be cancelled if the brake pedal is actuated or if the vehicle speed drops below 40 km/h/25 mph.

- 4 = Resume
If the lever is briefly pushed to position "4" when driving at a

speed exceeding approximately 40 km/h/25 mph, that speed is resumed which was set prior to the cancellation of the cruise control. The last memorized speed is cancelled when the key in the steering lock is turned to position "1" or "0".

Important:

Please do not use the cruise control if traffic conditions do not make it advisable to maintain a steady speed, i. e. in heavy traffic or on twisting or slick and muddy roads.

Position "Resume" should be engaged only if the driver is fully aware of the previously set speed and wishes to resume this particular preset speed.

When driving with the cruise control, the selector lever must not be shifted to position "N" as otherwise the engine will overrev.

Various Equipment

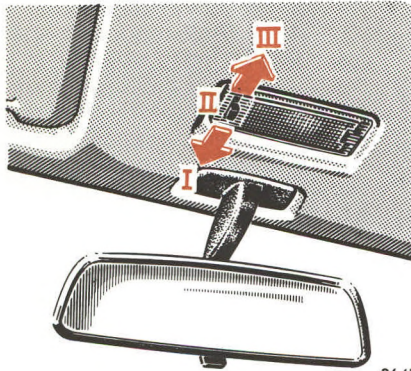

Interior Lamps

The switch for the front lamp has 3 position.

Position I: lamp is switched on and off by the front door contact switches.

Position II: lamp is continuously switched off.

Position III: lamp is continuously switched on.

The rear passenger compartment lamp is switched on and off by the rear door contact switches or by the rocker switch on the instrument panel.

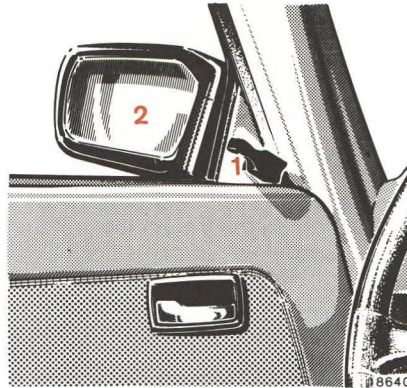

Outside Rear View Mirror

Outside rear view mirror (2) can be randomly adjusted from inside by means of lever (1).

If the mirror housing has been forcibly removed from its safety catch, it must be repositioned by applying firm pressure.

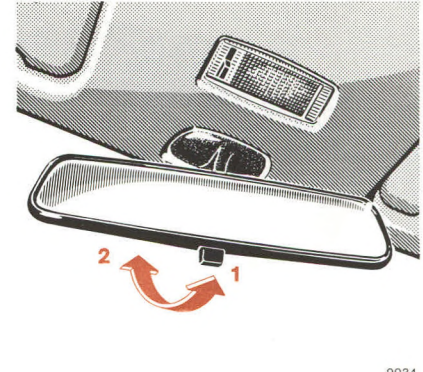

Inside Rear View Mirror

The mirror can be tilted to the anti-dazzle position by means of the lever at its lower edge.

1 = Normal position

2 = Anti-dazzle position

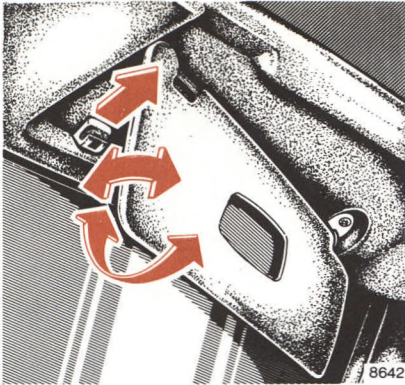

Sun Visor

To protect against sunlight from ahead, fold the sun visor downwards.

In the event of strong sunlight through the side windows, remove the sun visor from its inner fixture and swing it sideways.



Heated Rear Window

Turn key in steering lock to position "2".

When the rear window heater is turned on, the white indicator lamp in the switch comes on.

A heavy load is imposed on the battery due to the high power

requirement. For this reason, switch off the heated rear window as soon as it is demisted or defrosted. It is shut off automatically after a maximum of 30 minutes. Always remove heavy layers of ice and snow first.

Shelf below Rear Window

Do not carry heavy or hard objects on the shelf below the rear window. Such items could become dislodged during hard braking or upon a vehicle crash causing distraction or serious injury to the vehicle occupants.

Various Equipment

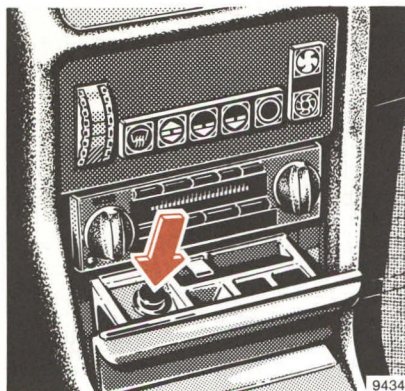

Electric Lighter

Key in steering lock position "1" or "2".

Press in electric lighter; it will pop out automatically when hot.

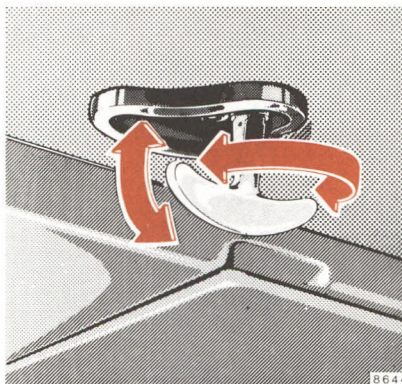

Sliding Roof

Manual operation

To release, swing down locking lever and turn by half a revolution to the stop. Slide roof to the desired position. To secure, turn back the locking lever to the stop and swing up.

Note:

For safety reasons the locking lever must be swung up every time the sliding roof is moved.

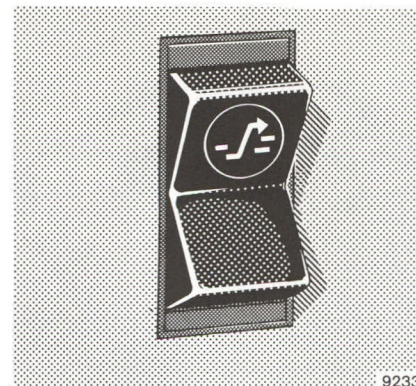

Electrical control

Turn key in steering lock to position "2".

Press upper end (symbol) of rocker switch to open roof, press lower end to close.

If the electric drive fails, the sliding roof can also be moved by hand. Refer to "Emergency Operating of Sliding Roof".

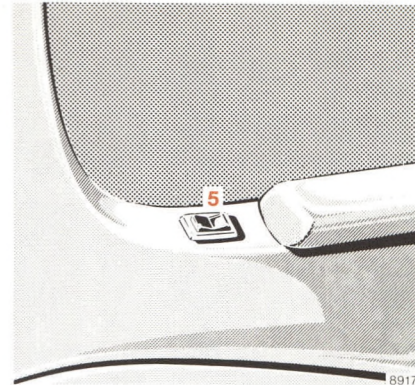
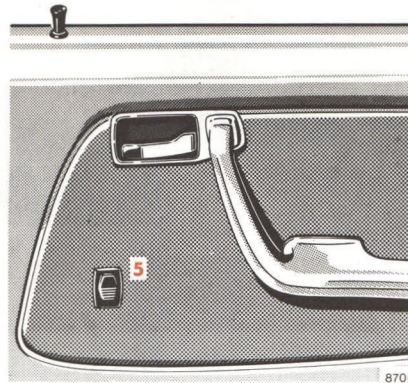
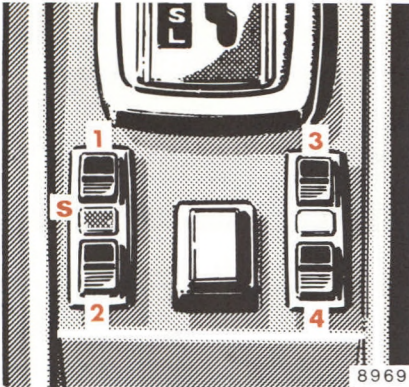

Electric Window Lifters

Switch group for window lifters:

- 1 front, left
- 2 rear, left
- 3 front, right
- 4 rear, right
- S Safety switch

The electric window lifters can only be operated with the steering lock in position "2". All four windows can then be operated using the switches in the center console. The rear door windows can also be operated using the switches (5) in each rear door

panel as long as the safety switch "S" in the center console is depressed. If the safety switch is not depressed, inadvertent operation of the rear door windows (for instance, by children) is prevented.

Automatic Climate Control

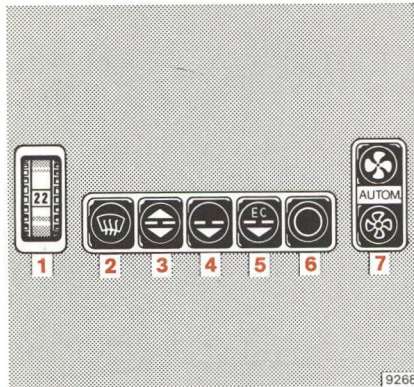

The automatic climate control system is designed to maintain the desired temperature in the vehicle interior. Heating, cooling and air distribution (top, center, bottom) are controlled automatically.

The automatic climate control system will work only if the engine is running.

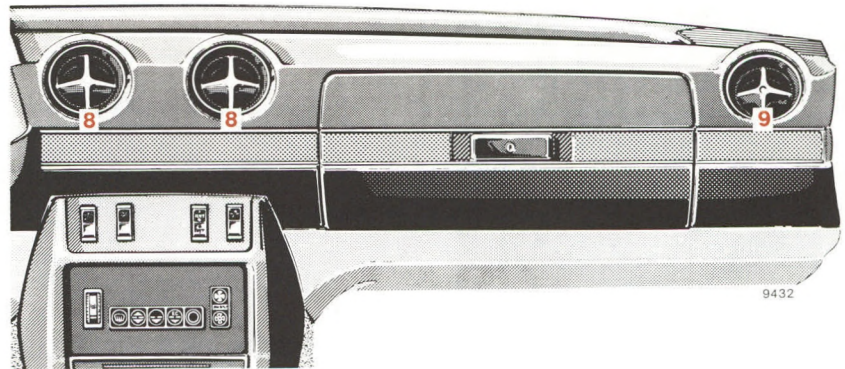

For adaptation to the weather conditions various functions can be selected with the push buttons. To do this, open, close or swivel air outlets 8 and 9 as required. The air outlets can be opened or closed by rotating the swivelling inserts (turn clockwise to open, turn counterclockwise to close).

In order to ensure that the automatic climate control functions properly, do not close all the air outlets 8 and 9.

Buttons 2–7 can only be pushed separately. The indicator lamps in the individual buttons come on if the buttons are pushed and the lighting switch is in position 1 or 2.

1 Temperature (°C)

The interior temperature can be adjusted infinitely by turning the temperature selector wheel between the two final notches “MIN” = no heating and “MAX” = full heat output. When the temperature selector wheel is turned to the desired comfort setting; this temperature is reached as quickly as possible and is maintained at the selected level. In order to avoid undesirable temperature fluctuations, a set temperature should be readjusted in small increments only.

2 Defrost

Air heated to the maximum temperature is channelled to the windshield regardless of the position of the temperature selector wheel 1.

To direct air to the side windows, open air outlets 9.

3 Bi-Level

In the heating and cooling modes, air is channelled to the windshield and footwells. In the

cooling mode, additional air is routed to outlets 8.

The vehicle interior is cooled down with the least possible drafts with the footwells receiving a larger volume of cooled air.

4 Normal

In the heating mode, most of the heated air is channelled to the footwell. Only sufficient air is channelled to the windshield to keep it free from mist under normal weather conditions.

In the cooling mode, cool air is only channelled to air outlets 8 and 9.

At low ambient temperatures the fresh air supply and the blower are switched off until the engine coolant has warmed up slightly.

5 Economy

EC (ECONOMY) = saving operation); the refrigerant compressor is switched off.

Control 5 is the same as control 4, but provides no cooling effect.

We recommend this setting at ambient temperatures when no cooling of the fresh air is required (saves fuel).

6 Off

If this control has been actuated, the fresh air supply to the vehicle is cut off (e.g. in the case of dust and fumes entering from outside).

7 Fan

If controls 3, 4 and 5 are actuated, the air volume can be adjusted as desired.

Push upper switch = maximum air volume

Push lower switch = minimum air volume

Push center switch = air volume is controlled automatically

Important:

In order to keep the automatic climate control in good working order, controls 3 and 4 need to be actuated briefly at least once a month. Ambient temperature must then be above +2° C/ +36° F.

Radio

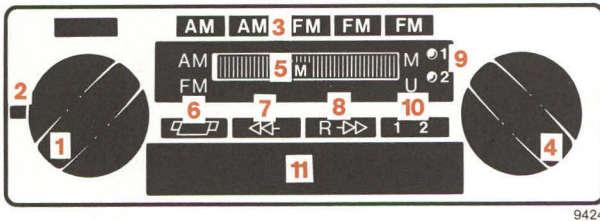

Europa Cassette
(Radio with Pushbutton Tuning and
built-in Cassette Player)

- 1 On-Off/Volume Control
- 2 Tone Control
- 3 Push buttons for band selection and tuning of preset stations
- 4 Manual tuning control
- 5 Wave band indicator
- 6 Cassette eject
- 7 Fast forward
- 8 Fast rewind
- 9 Track indicator
- 10 Track change-over button
- 11 Cassette slot

The radio can only be operated with the ignition key in the number "1" or "2" position.

On-Off/Volume

Turn knob (1) clockwise to switch radio on and to increase volume. Green control lamp on the dial will light up.

Tone

Turn lever (2) clockwise to increase treble range and counterclockwise to increase bass range.

Front-Rear Speaker Balance

This control is installed whenever the vehicle is equipped with rear speakers. Turn rearward to increase volume of rear speakers and forward to increase volume of front speakers.

Station Tuning

Select desired band by pushing the respective button (3). The band selected is indicated by the band indicator (5). The desired station is tuned in by turning the manual tuning knob (4). For good reception, accurate manual tuning is important.

To preset stations of various bands, pull out preset button (3) to the stop,

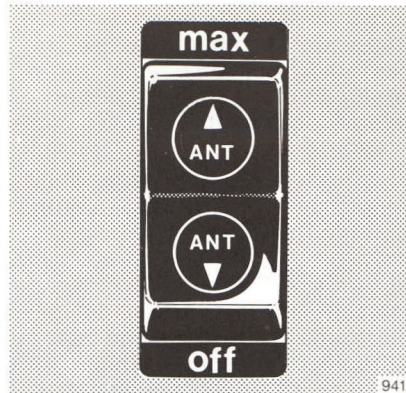

tune in station with manual tuning knob (4) and push preset button in again to the stop.

Automatic Antenna

The antenna switch can be actuated with the radio switched on and the key in steering lock positions "1" or "2".

- If the antenna switch is in center position, the antenna extends automatically to a specific height,

- if the antenna switch is engaged in the "max." position, the antenna extends fully,
- if the antenna switch is engaged in the "off" position, the antenna will not extend or will retract completely.

The height of the antenna can furthermore be adjusted continuously by actuating the antenna switch:

- If the antenna switch is in center position, the antenna will extend to the specific height. The antenna can be further extended or retracted to any height by rocking the switch (not engaging it).
- If the antenna is to be retracted, e.g. for playing cassettes, engage switch in "off" position.

When the key is turned to steering lock position "0" or the radio is turned off, the antenna will retract completely.

FM Reception

FM signals travel in a “line-of-sight”. Reflections or “dead spots” may cause cancellations or loss of the signal as well as strong signal overloading or capture.

Lowering the antenna height in strong signal areas may eliminate many of the resulting problems and restore clarity. However, fringe area reception requires the full antenna fully extended to receive weak incoming signals. The antenna can be operated by depressing the respective side of the rocker switch.

FM Stereo Reception

If an FM stereo station is tuned in, the red Stereo Indicator Lamp will come on. Good quality stereo reception, however, is possible only in areas of high field intensity.

Accurate tuning to the strongest available stereo stations is of particular importance for fringe area reception.

Your radio is fitted with a continuously operating Stereo Decoder which automatically switches the

radio from stereo to mono reception if the signal becomes too weak. The Stereo Indicator Lamp remains lit. If the signals of the station tuned in become too weak, the Stereo Indicator Lamp goes out.

The radio will return to stereo mode automatically when signal strength permits.

Tape Playback

Insert cassette (side 1 pointing upwards) into cassette slot and push in to the stop. The radio will then switch over from radio reception to tape playback.

If one side of the tape is finished the player changes over to the other side of the tape automatically (continuous operation).

If tape sides are to be changed while playing, push track changeover button (10).

Track indicator (9) indicates the tape side being played.

To manually eject the cassette, push release bar (6). When the cassette is ejected, the unit will switch over to radio reception automatically.

Push button 7 or 8 for fast forward or rewind of the tape. Briefly touching the counteracting button will stop the rewinding process.

Care of the Tape Player

Use only good quality cassettes with a maximum playing time of 45 minutes per side (C 90). “Unwound” tapes can be fixed by rewinding either reel with a pencil inserted in its hub. The pick-up head and roller should be cleaned occasionally to maintain the original high quality sound reproduction.

Driving



Hood

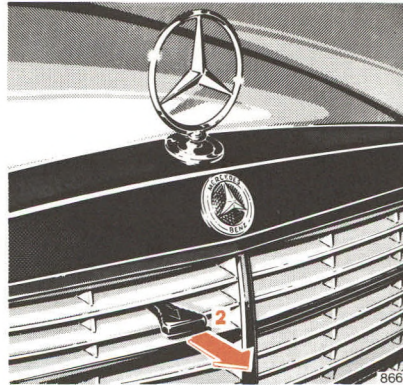
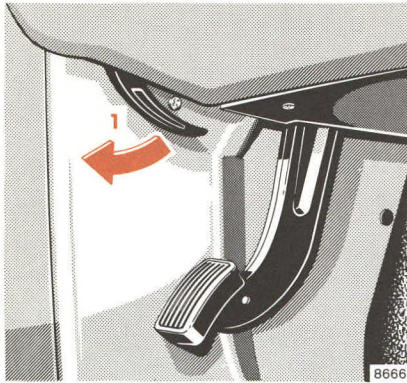

To open:

Pull lever (1) under the LH side of the instrument panel to unlock the hood. The hood opens to the safety catch stop. At the same time grip (2) will pop out of the radiator grille.

Pull grip (2) out of the radiator grille as far as the stop and lift up hood (windshield wiper arms must not be folded out).

Closing:

Close hood by depressing it firmly.

Note:

There is a risk of injury when the hood is open and the engine is running.

The engine is equipped with a transistorized ignition system. Because of the high voltage it is highly dan-

gerous to touch any components (ignition coil, distributor, spark plug sockets, ignition cables, diagnostic socket) of the ignition system

- if the ignition is "on" and the engine revved manually
- while starting the engine
- with running engine

Have the following items checked regularly and prior to any long trip

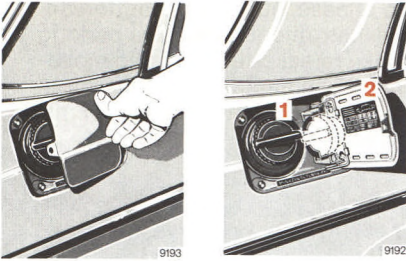

1 Fuel Supply

Use unleaded gasoline, for octane rating see "Capacities and last page".

2 Tire Pressure

For tire pressure table refer to fuel filler flap or last page. Check at least every other week. For more details see "Wheels, Tires, Changing Wheels".

3 Oil/Fluid Level: Engine, Automatic Transmission

See "Checking Fuels, Coolants, Lubricants, etc.", "Fuels, Coolants, Lubricants, etc. and last page".

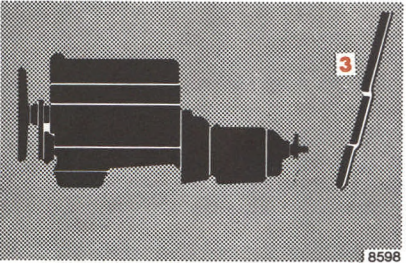

4 Coolant Level

See "Checking Fuels, Coolants, Lubricants, etc.", "Fuels, Coolants, Lubricants, etc. and last page".

5 Brake Fluid

When the minimum mark on the reservoir is reached, have the system checked (brake lining thickness, leaks).

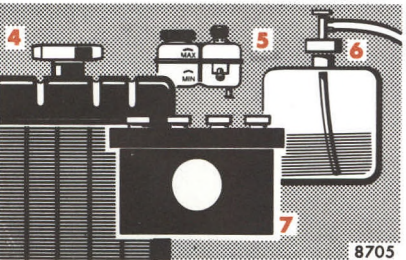

6 Windshield Washer

Replenish with water mixed with windshield washer detergent (container is in the engine compartment).

7 Battery

Replenish with distilled water only. See "Electrical System".

Vehicle Lighting

Check for function and cleanliness.

Parking Brake

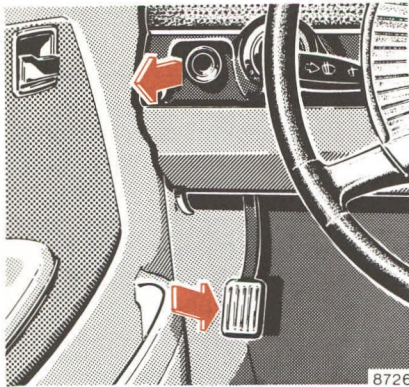

Depress parking brake pedal. When the steering lock key is in position "2", the brake warning lamp in the instrument cluster comes on.

To release, pull release button on the instrument panel. The parking brake releases in one rapid movement. The parking brake warning lamp in the instrument cluster must go out.

Your MERCEDES-BENZ is equipped with monolithic catalytic converters, an important element in conjunction with the O₂ sensor to achieve substantial control of the pollutants in the exhaust emissions. Keep your vehicle in proper operating condition by following our recommended maintenance instructions as outlined in your maintenance booklet.

Should any noticeable irregularities in the engine operation occur such as misfiring of one or more cylinders, indicated by audible signs, excessive unburned fuel may reach

the converter causing it to overheat. Continued operation of your vehicle can result in damage to the converter.

For the same reason we caution against:

- Misuse or abuse of your vehicle engine
- Refueling with leaded gasoline
- Excessive idling with cold engine
- Push or tow starting your vehicle with hot engine.

As with any vehicle, do not idle or park or operate this vehicle in areas where combustible materials such as grass, hay or leaves can come into contact with a hot exhaust system, as these materials could be ignited.

We urge your cooperation by following the above instructions to achieve cleaner air.

Starting and Turning off the Engine

Engage parking brake or service brake before starting the engine.

Place the gear selector lever in either “N” or “P” position before starting the engine.

Turn key in steering lock to position “2”. The charge indicator lamp must come on.

Cold Engine

Turn key in steering lock clockwise to the stop. If necessary, depress the accelerator slowly after the engine has started firing.

Release key only when the engine is running smoothly.

Hot Engine

Turn key in steering lock clockwise to the stop. Do not actuate accelerator. If the engine has not fired after approx. 4 seconds, depress accelerator to the floor and continue

cranking until the engine runs smoothly. Release key and back off accelerator after the engine has started.

Cold Start at Normal Ambient Temperatures (about 15°C – 35°C/59°F – 95°F)

Turn the key in steering lock clockwise to the stop. Start without actuating accelerator.

Release key only when the engine is running smoothly.

Turning off

Turn the key in the steering lock to position “0” and only remove the key when the vehicle is at standstill.

If the coolant temperature is very high (e. g. after hard driving on mountain roads), do not shut off the engine immediately but allow it to run on for 1 – 2 minutes at increased idle speed.

Hints

Observe the oil pressure gauge immediately after starting the engine. In a very cold engine the oil pressure will only rise slowly, some time after the engine has started. Do not rev up the engine before pressure is registered on the pressure gauge.

The charge indicator lamp must go out as soon as the engine has started.

Do not engage the starter continuously for more than 20 seconds.

At ambient temperatures of less than –20°C/–4°F, depress the accelerator three times prior to starting.

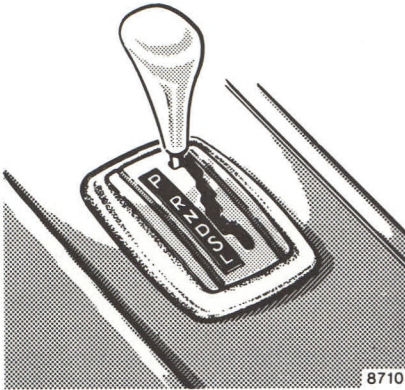

Do not store any objects in the driver's footwell area because they could become lodged under the operator's pedals thus rendering these controls partially or totally inoperative.

Test service brake after driving off.

Warm up the engine smoothly. Do not place full load on the engine until the operating temperature has been reached.

Automatic Transmission

The automatic transmission facilitates and simplifies the handling of the vehicle. The individual gears are shifted automatically dependent upon selector lever position, vehicle speed and accelerator position.

Hint

When parking the vehicle or if working on the vehicle with the engine running, depress parking brake pedal and move selector lever to position "P".

Starting

Shift selector lever to the desired driving position only when the engine is idling and the service brake is applied. Do not release the

brake before moving off. The vehicle may otherwise start creeping when the selector lever is in a driving position.

Accelerator position

Partial throttle = early upshifting = normal acceleration

Full throttle = retarded upshifting = maximum acceleration

Depressing the accelerator beyond full throttle to kickdown position means downshifting to the next lower gear and thus maximum acceleration. If you ease up on the accelerator after having attained the desired speed, the transmission will shift up again.

Gearshifting is controlled by the vehicle speed.

Starting and Shifting Gears

Selector lever positions

The automatic gear shifting process can be adapted to specific operating conditions by means of the selector lever.

- “P” Parking lock. The parking lock is an additional safeguard when parking the vehicle. Engage only when the car is stationary.
- “R” Reverse gear. Shift reverse gear only with the vehicle at halt.
- “N” Neutral. No power is transmitted from the engine to the rear axle. When the brakes are released, the vehicle can be moved freely (pushed, towed or tow-started). Do not engage “N” when driving except when the vehicle is in danger of skidding (e.g. on icy roads). See page 43.
- “D” Drive. All gears are available. 1st gear can be engaged only by means of kickdown.

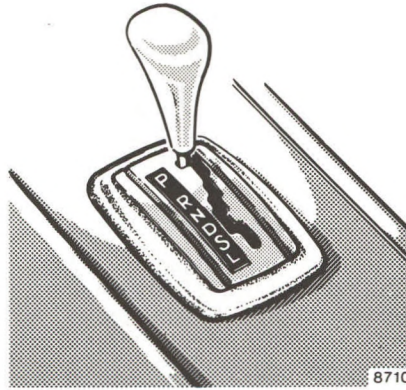

Position “D” affords optimum driving characteristics under all normal operating conditions.

- “S” Slope. Shifting up to 3rd gear only. 1st gear can be engaged only by means of kickdown. Suitable for moderate ascents and descents. As the transmission is shifted up to 3rd gear

only, this position permits the utilization of the engine braking effect. If the selector lever is in position “S”, upshifting from 2nd to 3rd gear will take place later than with the selector lever in position “D”.

- “L” Low. Upshifting to 2nd gear only. The vehicle starts out in 1st gear. For driving on steep mountain passes, for trailer operation in mountainous regions, under severe operating conditions and as braking position on extremely steep declines. If the selector lever is briefly shifted to position “S” and then returned to position “L”, 2nd gear is shifted sooner at higher speed.

Do not exceed top speeds in the individual selector lever positions. Refer to speedometer markings.

Starting and Shifting Gears

Maneuvering

To maneuver in restricted area, e. g. when pulling into a parking space, control the car speed by gradually releasing the service brake. Accelerate gently and do not pump the accelerator. To rock a car out of soft ground (mud or snow), alternately shift one forward gear range and the reverse gear at partial throttle.

Trailer operation

Do not allow the engine speed to drop too low at uphill gradients to prevent the engine from laboring at low RPMs. Depending on the degree of the incline, shift selector lever to positions "S" or "L" early enough to maintain engine RPMs within best torque range.

Stopping

For brief halts, e. g. at traffic lights, leave the selector lever in a driving position and control vehicle with the service brake.

For longer stops with the engine idling, shift selector lever to position "N".

When stopping the car on a slope, do not hold it by means of the accelerator but use the brake. This avoids unnecessary heat-up of the transmission.

Safe Driving

Always drive according to the rule "Safety first". The comfortable ride of the vehicle may easily tempt you to underestimate the speed you are actually driving at. For this reason you should get used to keeping an eye on the speedometer needle because high speeds demand long stopping distances.

Do not attempt to move or roll the vehicle with the engine not in operation, as engine-driven accessories such as the power steering system or power brakes are not "powered", therefore, requiring substantially more effort for their operation even though they always remain mechanically operative.

Do not allow your tires to wear down too far. With less than appr. 3 mm/ $\frac{1}{8}$ in of tread, the antiskid properties on a wet road fall off sharply.

Depending upon the weather and/or road pavement, the grip of the tires varies widely.

The retention of the specified tire pressure is essential. This applies particularly if the tires are subjected to high loads (e. g. high speeds,

Safe Driving

heavy loads, high ambient temperatures).

Aquaplaning:

Depending on the depth of the water layer on the road, aquaplaning may occur even with tires still showing the full tread depth, and even at low speeds. Avoid track grooves in the road and apply brakes cautiously in the rain.

Tire friction:

Dry road = 100%

Wet road = from approx. 50% to approx. 80% (be particularly cautious on wet and dirty roads)

Icy road = approx. 15%

A given speed at which a vehicle driven on dry roads can still be fully controlled must be reduced when the same vehicle is to be driven safely on a wet or icy road.

You should pay particular attention to the condition of the road as soon as the prevailing temperatures fall close to the freezing point. If ice has formed on the road (e. g. due to fog), a thin film of water is then

quickly produced on the ice which substantially reduces the grip of the tires. Under such weather conditions, drive, steer and brake particularly carefully.

We recommend M+S radial-ply tires for the cold season. On ice or packed snow, they can reduce your stopping distance as compared with summer tires. Stopping distance, however, is nevertheless considerably greater than when the road is wet or dry.

When driving down long and steep declines relieve the brakes by engaging selector lever position "S" or "L". This prevents overheating of the brakes and reduces brake pad wear.

After hard braking it is advisable not to switch off the engine right away but to drive on for some time so the air stream will cool down the brakes faster.

When driving in heavy rain for some time without applying the brakes, the first braking action may be

somewhat retarded and increased pedal pressure may be necessary. For this reason, stay further away from vehicle in front.

The condition of the parking brake will be checked during every maintenance service. Furthermore it is recommended to exert once or twice between the regular maintenance services, a maximum pressure of 10 kp/22 lb on the parking brake pedal for 10 seconds while travelling at a speed around 50 km/h/30 mph on dry road. Pull release knob during this process! Repeat procedure once or twice. Exercise care, the stoplamps do not work.

Have all inspections of and work on the brake system carried out by a MERCEDES-BENZ service station.

If the parking brake is released and the brake warning lamp in the instrument cluster comes on, the brake fluid level in the reservoir is too low.

A leak or brake pad wear may cause a shortage of brake fluid in the reservoir.

Have brake system checked in a MERCEDES-BENZ service station as soon as possible.

Install only brake pads recommended by us.

If other than recommended brake pads are installed, the braking properties of the vehicle can be affected to an extent that the safety is substantially impaired.

Brake Pad Wear Indicator Lamp

The brake pad wear indicator lamp in the instrument cluster comes on when the key in the steering lock is turned to driving position "2" and it must go out when the engine is running. If the indicator lamp lights up during braking or driving, this shows that the front wheel brake pads are worn down.

Have brake system checked in a MERCEDES-BENZ service station as soon as possible.

Brake Fluid

During the course of the operation of the vehicle, the boiling point of the brake fluid is continuously being reduced through the absorption of moisture from the atmosphere. Under extremely hard operating conditions, this moisture content can lead to the formation of vapor in the system thus reducing the system's efficiency. The brake fluid must therefore be replaced annually, preferably in the spring. It is recommended to use only brake fluid approved by MERCEDES-BENZ.

Your MERCEDES-BENZ dealer will provide you with additional information.

Charge Indicator Lamp

Should the charge indicator lamp fail to come on prior to starting when the ignition key is in position "2" or should it fail to go out after starting or during operation, this indicates a fault which must be repaired at a MERCEDES-BENZ service station as soon as possible.

Oil Pressure Gauge

The oil pressure may drop at idle speed to 0.5 bar/7.1 psi if the engine is at operating temperature. This will not jeopardize its operational reliability. Pressure must, however, rise immediately upon acceleration.

The oil pressure gauge does not provide any information concerning the oil level in the engine.

Coolant Temperature Gauge

Due to the pressurized cooling system, the coolant only starts boiling at a temperature of approx. 125° C/ 257° F with an antifreeze-blended coolant fill protecting down to -30° C/ -22° F (see also "Fuels, Coolants, Lubricants, etc.").

During severe operating conditions and stop-and-go city traffic the coolant temperature must not rise above the red marking.

Emission Control

Certain systems of the engine serve to keep the toxic components of the exhaust gases within permissible limits required by law. (Nevertheless, we urgently advise you not to let the engine run in a closed garage.)

These systems, of course, will function properly only when maintained strictly according to factory specifications. Any adjustments on the engine should, therefore, be carried out only by qualified MERCEDES-BENZ technicians. The adjustments of the engine should not be altered in any way. Moreover, the specified service and maintenance jobs must be carried out regularly according to MERCEDES-BENZ servicing requirements. For details refer to Maintenance Booklet.

Engine Oil Consumption

Engine oil consumption can only be determined after a certain mileage has been covered. During the break-in period, higher oil consumption may be noticed and is normal.

Frequent high engine speed operation will also cause increased oil consumption.

The more cautiously you treat your engine during the break-in period, the more satisfied you will be with its performance later on. Therefore, drive your vehicle during the first 1500 km/1000 miles at moderate vehicle and engine speeds.

During this period, avoid heavy loads (full throttle driving) and high RPMs (no more than $\frac{2}{3}$ of maximum permissible speed in each gear) and do not force the engine to labor at low engine speed.

Avoid accelerating by kickdown. It is not recommended to brake vehicle by means of manually shifting to a lower gear. We recommend to select positions "S" or "L" only at moderate speeds (for hill driving).

After 1500 km/1000 miles, speeds may gradually be increased to the permissible maximum.

Winter Driving

Have your car winterized in a MERCEDES-BENZ service station before the onset of winter.

- Engine oil change: If no “allyear round” engine oil is used, fill with recommended winter oil. For viscosity and capacity, refer to “Fuels, Coolants, Lubricants, etc. and last page”.
- Antifreeze in the coolant: Check antifreeze protection periodically. For capacity refer to “Fuels, Coolants, Lubricants, etc.”.
- Additive in the windshield washer system: Add windshield washer solvent to the water in the windshield washer system.
- Test battery: Battery capacity drops with decreasing ambient

temperature. A well charged battery ensures that the engine can always be started, even at low ambient temperatures.

- Tires: We recommend M + S radial tires on all wheels for the winter season. Observe permissible maximum speed for M + S radial tires and the legal speed limit.

Hints for Driving

The most important rule for slippery or icy roads is to drive sensibly and to avoid abrupt acceleration, braking and steering action. Do not use the cruise control system under such conditions.

When the vehicle is in danger of skidding, move selector lever to position “N”. Try to keep the vehicle under control by means of corrective steering action.

Provided the traffic conditions will allow, only brake in a way that the wheels are locked for no more than fractions of a second as otherwise the steerability of the vehicle is lost.

Thawing salts and water can adversely affect the braking efficiency. Increased pressure on the pedal may be required to achieve the usual braking effect. We therefore recommend you to actuate the brakes repeatedly in order to test their efficiency after driving on salt treated roads for some time. In doing this it must, of course, be made sure that no danger is created for other road users.

If the vehicle is parked after being driven on salt treated roads, the braking efficiency should be tested as soon as possible after driving is resumed while adhering to the safety requirements. Should the braking efficiency have deteriorated considerably it can be improved again by braking several times.

Special Operating Conditions

Tire Chains

Tire chains can only be used on the driving wheels. Use only chains tested and recommended by us. Any MERCEDES-BENZ service station will readily advise you.

Retighten newly mounted tire chains after a few miles of driving. Do not exceed permissible maximum speed of 50 km/h/30 mph. On clear roads, remove the chains as soon as practicable. Adhere to the manufacturer's mounting instructions.

Traveling Abroad

Abroad, too, there is a widelyspread MERCEDES-BENZ service network at your disposal. If you travel into areas which are not listed in the index of your service station booklet, you should request pertinent information from your dealer.

Vehicle Care

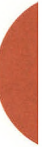

MERCEDES-BENZ Maintenance System

Like any other mechanical equipment, the vehicle requires care and maintenance.

A maintenance booklet is delivered with your car listing all the maintenance jobs that must be carried out after the following mileages:

- Once after 1300 – 1600 km/ 800 – 1000 miles.
- After 12000 km/7500 miles.
- After 24000 km/15000 miles and thereafter every 24000 km/ 15000 miles, but at least once every two years.

We would also like to draw your attention to the hints contained in the maintenance booklet covering necessary lubrication service every 12000 km/7500 miles, additional maintenance jobs every 48000 km/ 30000 miles and MB individual maintenance as required.

Renew brake fluid once a year, preferably in spring. Use only brake fluids recommended by MERCEDES-BENZ.

The vehicle must receive the prescribed maintenance and/or lubrication work at the specified intervals as listed in the maintenance booklet. Verification of performance of such maintenance/lubrication work should be recorded in the spaces provided in the maintenance booklet.

The maintenance jobs are described in detail in a manual which you can order from your MERCEDES-BENZ service station.

Severe Operating Conditions

In the case of severe operating conditions or heavy use mainly in city traffic or over short distances, frequent mountain driving, poor roads, dusty and muddy conditions, trailer operation, hard and sporty driving, etc. it may be necessary to inspect e. g.

- the tires
- air cleaner (clean or renew element)

at shorter intervals.

Any MERCEDES-BENZ service station will be pleased to give you expert and individual advice.

Engine Oil Change and Filter Change

To be carried out every 12000 km/ 7500 miles, but at least once a year if year-round multigrade oil is used. Otherwise at least twice a year (in spring and fall).

Under severe operating conditions, the oil and filter should be changed every 6000 km/3750 miles.

For regular oil level checks, refer to "Checking Fuels, Coolants, Lubricants, etc.".

Automatic Transmission – Fluid and Filter Change

To be carried out every 48000 km/ 30000 miles according to the maintenance booklet.

Under severe operating conditions, have the automatic transmission fluid changed every 24000 km/ 15000 miles without filter change.

All MERCEDES-BENZ service stations store the MERCEDES-BENZ original spare parts required for maintenance and repair work. In addition, depots are provided all over the globe intended to ensure the rapid supply of MERCEDES-BENZ original spare parts.

More than 200 000 different spare parts, even for rather old vehicle models, are furthermore stocked in the central plant warehouses.

The maximum operational efficiency and reliability as well as optimum retention of the vehicle value can be maintained when MERCEDES-BENZ original spare parts are installed, as

they are subjected to most severe quality inspections. Each part has been specifically developed, manufactured or selected for and adapted to MERCEDES-BENZ vehicles.

For this reason, only MERCEDES-BENZ original spare parts should be installed.

Cleaning and Care of the Vehicle

In operation, your vehicle is subjected to a great amount of varying external influences which, if gone unchecked, can attack the paintwork as well as the underbody and cause lasting damage.

Such damage is caused not only extreme and varying climatic conditions, but also by air pollution, road salt, tar, gravel and stone chipping. Grease and oil, fuel, coolant, brake fluid, bird droppings, tree resins, etc. should be immediately removed to avoid paint damage. Frequent washing, however, reduces and/or eliminates the aggressivity and potency of the above adverse influences.

Special car-care measures may be necessary to deal with unfavorable conditions; for example, near the coast, in industrial areas (smoke, exhaust emissions), or during winter operation.

You should check over your vehicle from time to time for stone chipping or other damage. Any damage should be repaired as soon as possible.

In doing so, do not neglect the underside of the car. A prerequisite for a thorough check is a washing of the underbody followed by a rustproofing treatment.

Your vehicle has been treated at the factory with a wax-base rustproofing in the body cavities.

After every engine cleaning you should have the engine compartment rustproofed. Before rustproofing, all control linkage bushings have to be lubricated with hydraulic oil (check with your local MERCEDES-BENZ dealership for recommended brands).

We have selected car-care products and compiled recommendations which are specially matched to our vehicles and which always reflect the newest in technological standing. You can obtain MB car-care products at every MERCEDES-BENZ service station.

Scratches, corrosive deposits, corrosion or damage due to negligent or incorrect care cannot always be removed with the car-care products recommended here. In such cases it is best to seek aid at your MERCEDES-BENZ service station.

The following topics deal with the cleaning and care of your vehicle and give important "how-to" information as well as references to recommended MB car-care products.

Car Wash

Before washing your vehicle, remove insect residues. The car should not be washed in the sun.

Thoroughly spray the car with a diffused jet of water. Direct only a very weak spray towards the ventilation intake. Use plenty of water and rinse the sponge and chamois frequently. Rinse with clear water and thoroughly wipe dry with a chamois.

If the vehicle has been run through an automatic car wash – in particular one of the older installations – rewipe the recessed sections provided in the tail lamps (for improved prevention of soiling) if necessary. No solvents (fuels, thinners etc.) must be used.

In the winter, thoroughly remove all traces of road salt as soon as possible.

When washing the car underbody, do not forget to clean the inner sides of the wheels.

Tar Stains

Quickly remove tar stains before they dry and become more difficult to remove.

Window Cleaning

Use a window cleaning solution on very dirty or oil-stained windows. Clean windshield wiper blades with a clean cloth and washing solution. Replace blades once or twice a year.

Plastic Parts, Rubber Parts and MB-Tex Upholstery Covers

Do not use oil or wax on these parts.

Seat Belts

The webbing must not be treated with chemical cleaning agents. Use only clear, lukewarm water and soap. Do not dry the webbing at temperatures above 80°C/176°F or in direct sunlight. Never bleach or re-dye the webbing.

Steering Wheel, Selector Lever and Instrument Cluster

Use a gentle dish-washing detergent or mild detergent for delicate fabrics as a washing solution. Wipe with a cloth moistened in lukewarm solution. Do not use scouring agents.

Cleaning and Care of the Vehicle

Upholstery

Leather: Wipe leather upholstery with a damp cloth and dry thoroughly. Exercise particular care when cleaning perforated leather as its underside should not become wet.

Velours: Pressure marks resulting from dampness and heat may appear to be stains. Such marks can be removed by wiping with a moistened brush, ironing with a wet cloth or by treating with a dry shampoo. Do not sit on damp upholstery. Quick drying is achieved by applying hot air –

for example, by using a hair dryer. If in doubt, please consult your MERCEDES-BENZ service station.

Paintwork

Do not apply wax if your car is parked in the sun or if the hood is still hot. For maximum protection, the paintwork should be waxed approximately once every three months. Use the appropriate MERCEDES-BENZ Touch-Up Stick for quick and provisional repairs of minor paint damage.

Light Alloy Wheels

If possible, clean wheels once a week with lukewarm water and auto-shampoo. Use an ample supply of water.

To remove stubborn marks, use polish or paint cleaner and apply with buffing cloth or a soft cloth.

Ornamental Moldings (Chrome-Plated, Aluminum)

For regular cleaning and care of very dirty chrome-plated parts, use a chrome cleaner.

Practical Hints

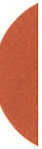

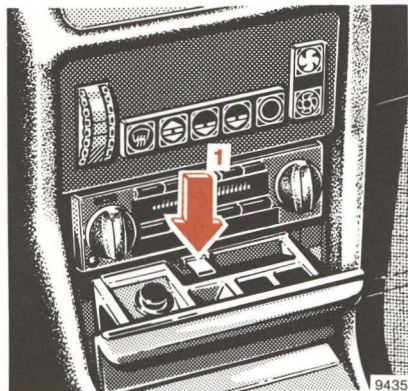

Ash trays

To remove front ash tray:
Pull ash tray out as far as possible.
Push down the spring (1) in the center and remove ash tray.

To install ash tray:
Position ash tray squarely and push in.

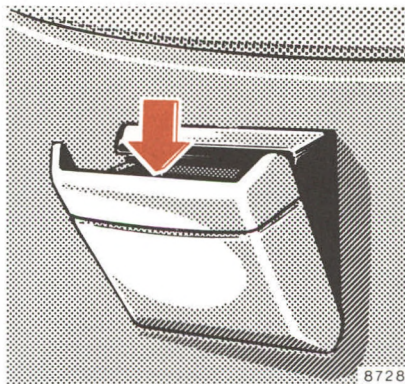

To remove rear ash tray:
Push the ash tray down while opening and remove.

To install ash tray:
Position ash tray squarely and push in.

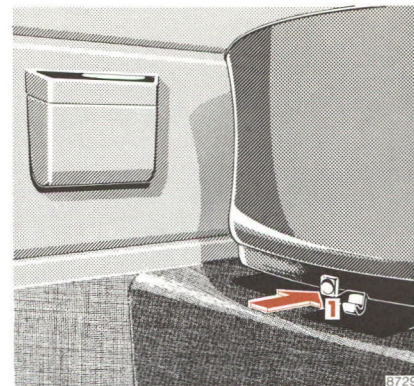

Rear Seat Cushion

Removal: Depress buttons 1 (left and right) and at the same time slightly lift up rear seat cushion at the front end. Then pull the cushion forward. (Center arm rest of rear seat cushion must be folded up.)

Installation: Push rear edge of rear seat cushion under the backrest to the stop, press down front edge onto the support and allow to engage.

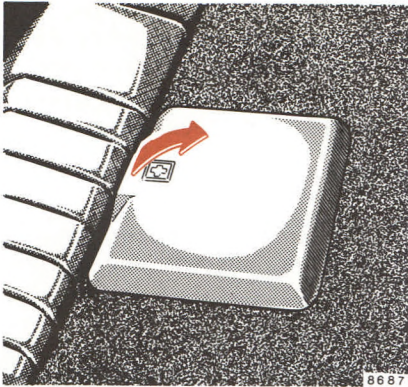

First Aid Kit

The first aid kit is stowed in a cavity in the hat shelf at the rear.

Luggage or Ski Racks

The only type of rack to be mounted on the roof we recommend is the drip rail mounted type which has no other supports (suction cups or legs) to support the rack on the roof. Such supports may lead to marring of the paint or even denting of the roof if excessive weight is placed on the rack.

Your MERCEDES-BENZ dealer can give further advice.

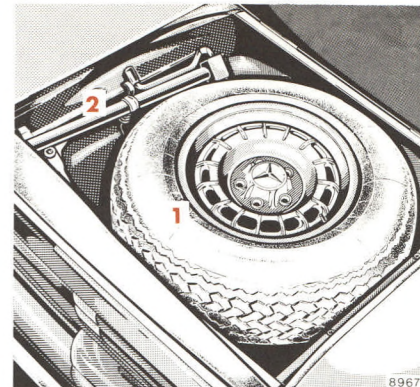

Spare Wheel, Jack, Vehicle Tool Kit

Spare wheel (1), jack (2) and the tool kit are stowed in a trough below the trunk floor.

Fold back trunk floor mat and remove cover plate.

Note:

The jack is designed exclusively for jacking up the vehicle at the jack tubes provided on either side of the vehicle. Jack stands must be used when working under the vehicle.

Wheels, Tires

In case of replacement we recommend you use tires of identical design, version and brand.

See any MERCEDES-BENZ service station for information on tested and recommended wheels and tires for summer and winter operation. They will also offer more advice concerning tire service and purchase.

Mount single newly acquired tires on the front wheels. If any tires are replaced and the spare tire is new and of the same make and version, mount the spare wheel on the vehicle as road wheel. We recommend that you break in new tires for approx. 100 km/60 miles at moderate speed.

On new rims it is imperative that the wheel securing bolts be retightened after approx. 800 km/500 miles. On new vehicles, retightening is carried out in the course of the 1st inspection. Retightening is also necessary when new wheels are fitted at a later date, e.g. when the spare wheel is used for the first time or when a new set of wheels with M+S tires is fitted.

For tire specifications, refer to "Technical Data".

Rotating wheels:

The wheels can be rotated according to the degree of tire wear while retaining the same sense of rotation. Rotating, however, should be carried out before the characteristic tire wear pattern (shoulder wear on front wheels and tread center wear on rear wheels) becomes visible at a mileage of 5000 – 10000 km/3000 – 6000 miles as otherwise the driving properties deteriorate.

Slowly leaking air (e.g. due to a nail in the tire) may cause damage to the tire such as tread separation. Regular tire pressure checks at intervals of no more than 14 days are therefore essential. For the tire pressure checks, keep in mind that hot tires show higher pressure than cold tires. See tire pressure chart on last page.

Should the tire pressure decrease constantly, check whether foreign objects have penetrated the tire or if rim or valve allow the air to leak.

Thoroughly clean the inner side of the wheels any time you rotate the wheels or wash vehicle underside.

Dented or bent rims cause tire pressure loss and damage to the tire beads. For this reason, check rims for damage at regular intervals.

The rim flanges must be checked for wear before a tire is mounted. Remove burrs, if there are any.

Observe wheel bolts!

- 1 For forged light alloy rims only
- 2 For steel rims only

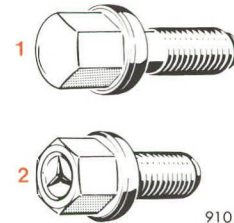

Caution:

Do not use the long wheel bolts (1) intended for light alloy wheels to mount steel rims. Use only the shorter bolts (2) for the steel rims.

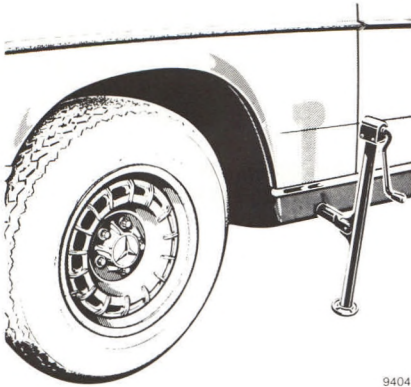

9404

Changing Wheels

1. Depress parking brake pedal.
2. Move selector lever to position "P".
3. Safeguard vehicle against rolling off by using chocks or similar. Place chocks under both opposite wheels (on downhill side), on a level road on both sides of the opposite front wheel when changing a rear wheel.
4. Using the combination wrench, loosen but do not yet remove the wheel bolts.
5. Clean jack supporting tube, if necessary. (Jack tubes are behind the front wheel housings and in front of the rear wheel housings.)
6. Insert jack arm into the tube hole up to the stop. Position the jack so that it will always be vertical as seen from the side, even on inclines. Jack up the vehicle until the wheel is clear of the ground.
7. Then back out the wheel bolts. Protect bolt threads from dirt and sand. Remove the wheel.
8. Adjust the jack to allow the wheel to be slipped on without being lifted.
9. Slip on spare wheel and press against wheel mounting flange. Screw in wheel bolts.

10. Lower car and remove jack. Tighten the five bolts evenly by going around the wheel and tightening every other bolt until all the bolts are tight. Observe a tightening torque 10 mkp/ 72 lb-ft.
11. Correct tire pressure.

Tire Pressure

A table (see fuel filler flap or last page) lists the tire inflation pressures specified for summer and winter tires as well as for the varying operating conditions.

Tire temperature and pressure increase with the vehicle speed. Tire pressure should therefore only be corrected on cold tires. Correct tire pressure in hot tires only if pressure has dropped below the data listed in the table and the respective operating conditions are taken into consideration.

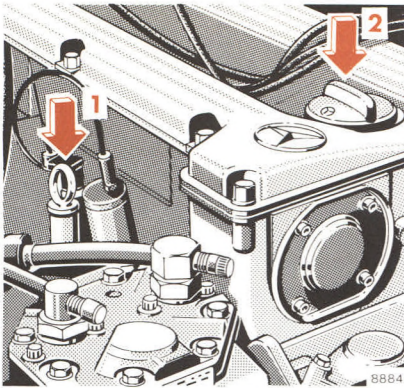

Engine Oil Level Check

1. Dipstick
2. Oil filler hole

Check engine oil level at regular intervals, e.g. after refueling, with the engine at operating temperature and shut off.



The vehicle should be parked on level ground and the oil level must be somewhere between the lower and the upper mark on dipstick (1); do not replenish in excess of the upper mark.

Wipe dipstick before any oil level measurement. To determine the oil level, check both sides of the dipstick. Always determine an accurate oil level by means of the straight horizontal marking formed by the oil on one side of the dipstick.

For viscosity and capacity, see "Fuels, Coolants, Lubricants, etc., and last page".

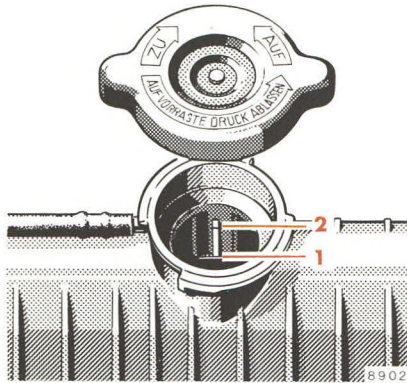

Replenishing Coolant

The coolant level must reach:

- to marking 1 if the coolant is cold,
- to marking 2 if the coolant is hot.

Do not remove radiator cap if engine temperature is above 90°C/194°F. Allow engine to cool down before removing cap. The radiator contains hot water and is under pressure.

First turn cap to first notch to relieve excess pressure using a rag. If opened immediately, hot scalding fluid and steam will be blown out under pressure.

If a small amount of coolant has to be added (due to evaporation of water), plain water can be added.

If a larger quantity of coolant has to be added, a 50/50 mixture of water and antifreeze should be used.

The drain plugs are on the RH side of the engine and LH bottom mount of the radiator.

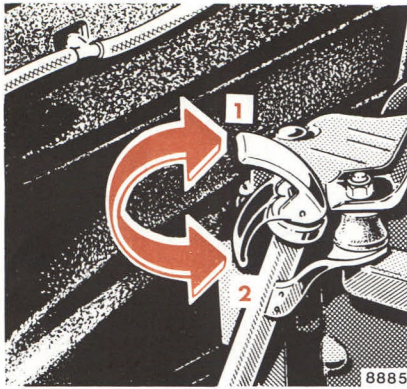

Fluid Level – Automatic Transmission

At regular intervals, check the fluid level of the automatic transmission together with the engine oil level prior to every long trip.

Check transmission fluid level with the engine idling, parking brake engaged and selector lever in position "P". The vehicle must be parked on level ground. Prior to the check, allow engine to idle for approx. 1 to 2 minutes.

Measure oil level with the dipstick completely inserted and the locking lever released (1).

Painstaking cleanliness must be observed!

To wipe the dipstick, use a clean, lint-free cloth (preferably leather).

To fill the transmission with fluid, only pour it through a fine-mesh filter into the dipstick opening. Even the slightest impurity may cause operational troubles.

The oil level in the transmission is dependent upon the oil temperature. The maximum and minimum oil level

marks on the dipstick are applicable references only if the transmission fluid has reached its normal operating temperature of 80°C/176°F. – If, however, the transmission fluid cools down to 20–30°C/68–86°F, which is the normal shop temperature range, then the maximum oil level will be approximately 30 mm/ 1.2 in below the minimum mark on the dipstick. We stress this point because an oil change is normally performed when the transmission oil has cooled down to shop temperature.

The fluid level must not exceed the dipstick maximum mark with the fluid at operating temperature. Drain or siphon off excess fluid, if required.

Then push dipstick all the way in and swing locking lever downwards (2).

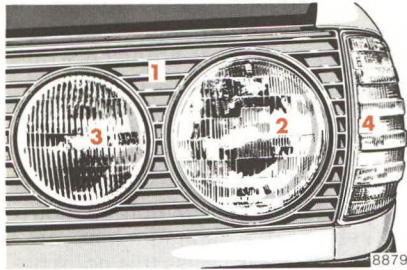

Replacing Bulbs

To remove, push the bulb in and turn to the left, then lift the bulb out.

To install, grip the bulb with a paper tissue or similar cloth, align the pins on the base of the bulb with the grooves in the bulb socket, push in lightly and turn to the right until the stop is felt.

Install only bulbs of prescribed wattage. Refer to "Technical Data and last page".

Headlamp Aiming

Correct headlamp aiming is of paramount importance to the road-worthiness of the car. Check and readjust headlamps at regular intervals and invariably when a lamp has been replaced.

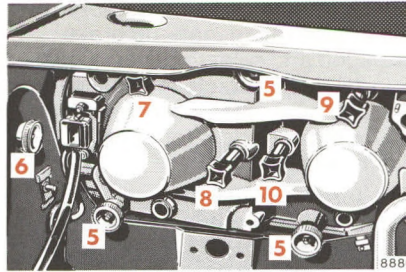

Front Lamps

- 1 Cover. Remove cover (1) after backing out knurled plastic nuts (5) located behind headlamps.
- 2 Sealed-beam unit for high and low beam
- 3 Fog lamp
- 4 Turn signal, parking, side marker and standing lamp
- 5 Securing nuts for cover

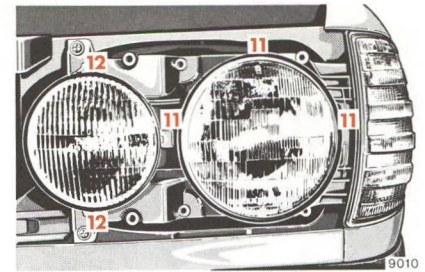

- 6 Securing nuts for turn signal, parking, side marker and standing lamp
- 7 Vertical aiming screw, sealed-beam unit
- 8 Horizontal aiming screw, sealed-beam unit
- 9 Vertical aiming screw, fog lamp
- 10 Horizontal aiming screw, fog lamp

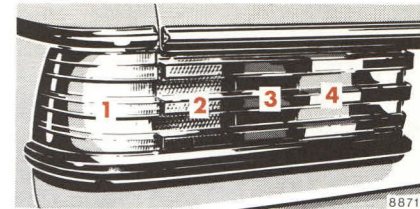
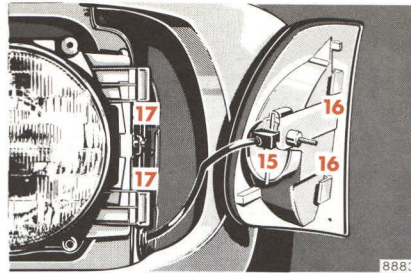
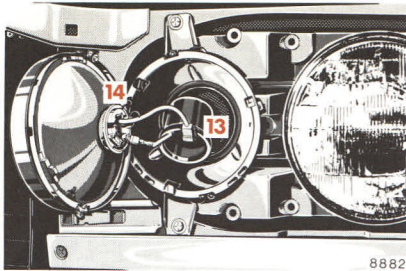

- 11 Securing screws for sealed-beam unit retaining ring. Loosen securing screws, remove retaining ring and unit. Pull off connector.
- 12 Securing screws for fog lamp retaining ring. Loosen securing screws and take out lamp body. Pull off plug (13). Disengage retaining spring and remove bulb (14).

- 15 Bulb for turn signal, parking, side marker and standing lamp. Loosen fastener (6). Push lamp body forward and detach. Hold lamp holder by the wide lug and pull out. Depress bulb, turn to the left and take out. When installing the bulb holder, the lugs must engage the lamp body recesses. When installing the lamp body, never fail to engage the locating webs (16) between the retaining springs (17).

Tail Lamp Assembly

Remove both knurled nuts in the trunk and pull off lens assembly. To replace the bulbs, depress, turn left and pull out.

- 1 Turn signal lamp
side marker lamp
- 2 Tail, parking and standing lamp
- 3 Stop lamp
- 4 Backup lamp

8870

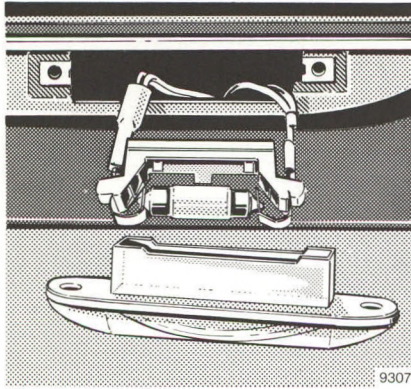

License Plate Lamps

Open trunk lid, loosen both securing screws of the lamp and remove lamp. Pull out lamp holder.

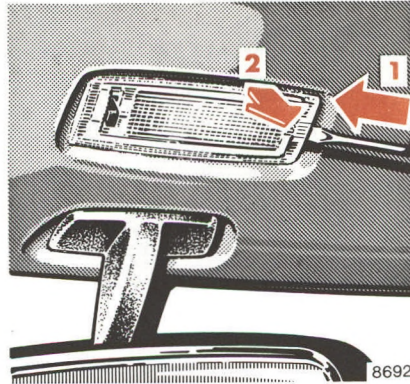

Courtesy Lamps

To replace the bulb, press courtesy lamp slightly towards the left (1), lift off at right-hand side (2) and pull out to the right.

The same applies when removing the rear courtesy lamp.

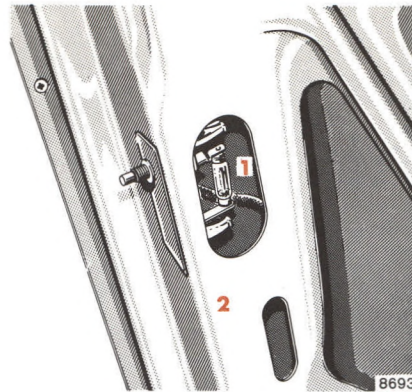

Trunk Lamp

The bulb (1) is easily accessible when the trunk lid (2) is opened.

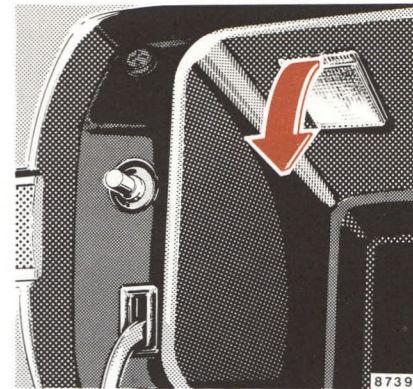

Glove Compartment Lamp

To replace the bulb, pull out lamp.

Electrical System

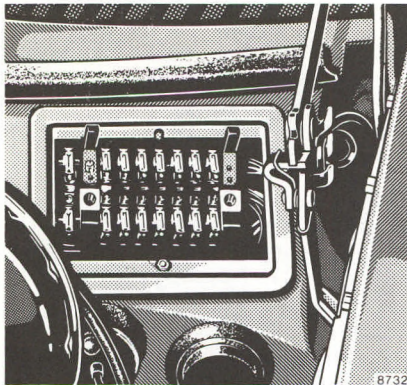

Fuses

The fuse box is located in the engine compartment.

A summary of the protected equipment is printed in the fuse box cover.

Fuse arrangement in the box – starting at engine side, proceeding from inside to outside –
upper row: odd numbers
1, 3, 5 etc. up to 13;

lower row: even numbers
2, 4, 6 etc. up to 14.

Fuses must be replaced, not repaired or bridged.

Spare fuses are stored in the fuse box (observe amperage and color code).

Determine the cause of a short prior to replacing a burned-out fuse.

After replacing a fuse, screw on the fuse box cover firmly.

Battery

Check the fluid level in the cells from outside approximately every 4 weeks, and more often in summer and in hot zones.

The fluid level must be between the lower and the upper markings.

Only replenish with distilled water. Do not use metal funnels and do not perforate the diaphragm of the battery overflow protection.

The battery is filled to the maximum level when the water level in the cell filling chamber stops going down.

If battery acid is to be extracted for battery diagnosis purposes, perforate the diaphragm with the hydrometer or the tube attached to it.

Coat battery terminal clamps with acidproof grease. Keep battery clean and dry.

Only tow vehicle with the battery connected.

Only charge battery with a battery charger when it is disconnected from the vehicle electrical circuit.

Note:

While the engine is running the battery terminal clamps must not be loosened or detached as otherwise the alternator and other electronic units would be damaged.

Spark Plugs

This vehicle is equipped with spark plugs as required for driving in the USA. Should additional information be necessary, your MERCEDES-BENZ dealer will be happy to offer advice.

Emergency Operating of Sliding Roof

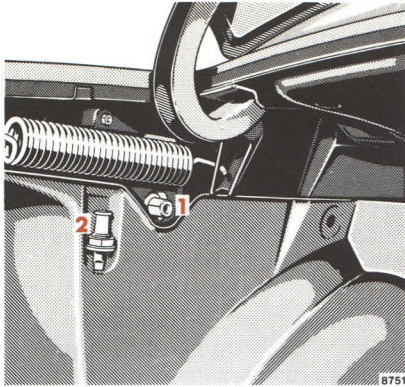

If the electric drive fails, the sliding roof can also be moved by hand. For this purpose a manual drive (1) has been provided on the drive motor (LH side of trunk). The manual drive can be rotated by means of

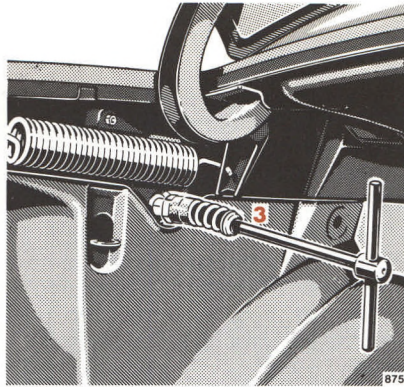

adapter (2) and spark plug wrench (3) to move the sliding roof in the desired direction. To close the sliding roof, turn clockwise.

Unlocking of the Fuel Tank Filler Flap

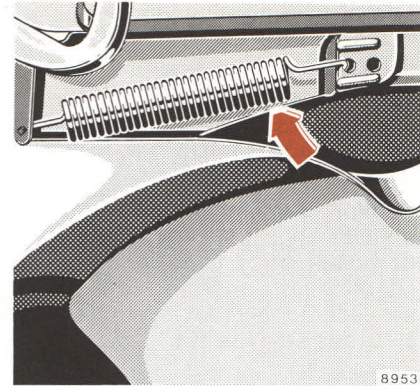

If the filler flap cannot be opened when the master lock system is unlocked, bend aside the covering on the RH side of the trunk somewhat and withdraw the link of the vacuum element.

Emergency-starting and Towing the Vehicle

Towing eyes are situated underneath the front and rear end on the R-H side. Use a solid towing link such as a towbar.

Only tow-start vehicle with the battery connected and the key in steering lock position "2".

Caution: Remember, however, that until the engine is running, the power steering and power brakes do not offer assistance and considerable additional effort is required to steer and stop the car.

Emergency Engine Start (Tow-starting)

The engine must be cold if it is to be started by towing or pushing the vehicle.

Never start a hot engine by towing or pushing the vehicle as the catalysts might otherwise suffer damage.

Move selector lever to position "N". Turn key in steering lock to position "2" and have vehicle towed.

After reaching a speed of 30 km/h/18 mph, maintain this speed for about two minutes in order to ensure sufficient oil pressure in the transmission.

To start the engine, move selector lever to "L". Only touch the accelerator when the engine is revolving. As soon as the engine has fired, return the selector lever to "N" immediately.

If the engine fails to fire within a few seconds, return the selector lever from "L" to "N" as otherwise the transmission may be damaged.

For another starting attempt, tow car again for a short while with the selector lever in position "N" and then repeat starting procedure.

The same procedure may be used for starting the engine while rolling downhill.

Towing a Vehicle

The vehicle may be towed with the driving wheels on the ground and the selector lever in position "N" for distances up to 120 km/75 miles and at a speed not to exceed 50 km/h/30 mph.

To positively avoid a possibility of damage to the transmission, however, we recommend to disconnect the drive shaft at the rear axle drive flange on any towing beyond a short tow to a nearby garage.

If the battery is discharged the engine can be started with jumper cables (minimum lead cross section is 35 mm²) and the (12 V) battery of another vehicle. Proceed as follows:

- Turn key to steering lock position "0".
- Run engine of jumper vehicle at high idle.
- First connect jumper cables to the positive battery terminals and then to the negative terminals.
- Start engine as normal.
- After the engine has started, first remove jumper cables from the negative battery terminals and then from the positive terminals.

Instructions:

A discharged battery can freeze at approx. $-10^{\circ}\text{C}/+14^{\circ}\text{F}$. In all cases it must be thawed out before jumper leads are used.

Never lean over batteries while jump starting, you might get burned.

Technical Data
Fuels Coolants
Lubricants etc.



Identification Plates

When ordering spare parts, please quote chassis and engine numbers.

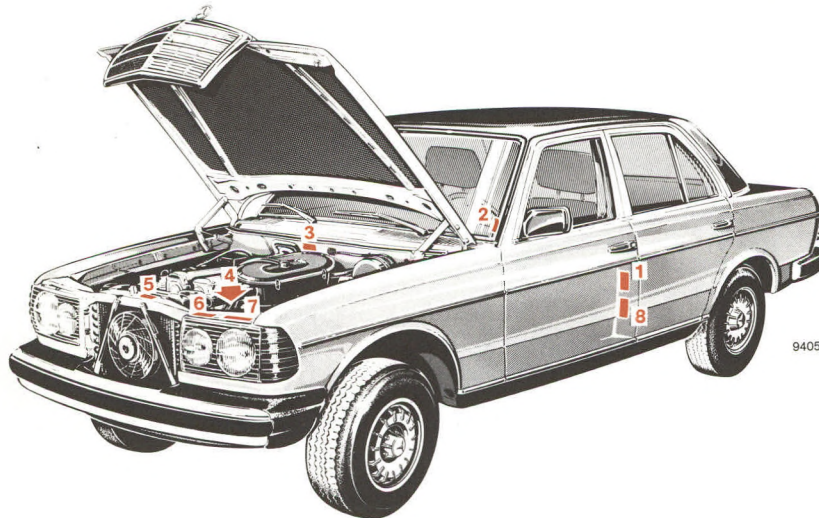

- 6 Information Tag
California version
Vacuum line routing
for emission control system
- 7 Emission Control Tag
- 8 Emission Control Tag
Catalyst Information

- 1 Certification Tag (left door pillar)
- 2 Identification Tag (left window post)

- 3 Chassis No.
- 4 Engine No.
- 5 Body No. and Paintwork No.

The diagram shows a rectangular form divided into several sections. The top section contains a grid of 10 columns and 5 rows. Below this is a section with 10 columns and 10 rows. The bottom section is a large grid with 10 columns and 15 rows. A large red number '1' is in the top-left corner, with a black arrow pointing to the right towards the top-left corner of the grid.

9073

The vehicle data cards bear all the important data relating to your vehicle.

Data card No. 1 bears the key number and should on no account be left in the vehicle. Submit this card to your MERCEDES-BENZ service station to request a replacement key in case of loss.

Data card No. 2 bears no key data and is kept in the maintenance booklet. Presenting this card to the service station will facilitate the processing of the order.

Technical Data

Type 280 E (123 033)¹
 280 CE (123 053)¹

Engine

Engine 110

Work cycle 4-stroke engine,
 gasoline injection

No. of cylinders 6

Bore 86 mm/3.39 in

Stroke 78.8 mm/3.10 in

Total piston displacement ... 2746 cm³/167.6 in³

Compression ratio 8

Output acc. to SAE 140 net bhp/5500 rpm

Valve clearance } Intake 0.10 mm/0.004 in
 (cold engine) } Exhaust ... 0.25 mm/0.010 in

Firing order 1-5-3-6-2-4

V-belts:

Water pump-fan-alternator .. 9.5× 980 mm
 Power steering 12.5× 818 mm
 Air conditioning 12.5× 1285 mm
 Air pump 9.5× 825 mm

Transmission

Design Automatic four-speed
 torque-converter
 transmission

Steering System

Design Power steering

Rims – Tires

Rims 6 J × 14 H 2

Summer tires:
 Radial-ply tires 195/70 HR 14

Winter tires:
 Radial-ply tires 195/70 SR 14 M+S

¹ The quoted data apply only to the standard vehicle. See a MERCEDES-BENZ service station for the corresponding data of all special bodies and special equipment.

Electrical System

Alternator	14 V/65 A
Starter motor	12 V/1.5 kW
Battery	12 V/55 Ah
Spark plugs	see "last page"

Bulbs 12 V

High and low beams	Sealed beam/Halogen
Fog lamps	H 3
Turn signal, clearance and side marker lamps, front	21/5 W/32/3 cp
Stop lamps	21 W/32 cp
Turn signal lamps, rear	21 W/32 cp
Side marker lamps, rear	4 W/ 2 cp
Tail and standing lamps	10 W/ 6 cp
Backup lamps	21 W/32 cp
License plate lamps	5 W festoon lamp
Interior lamps	10 W festoon lamp
Trunk lamp	10 W festoon lamp
Glove compartment lamp	5 W festoon lamp

Weights See certification tag

Main Dimensions 280 E

Overall vehicle length	4848 mm/190.9 in
Overall vehicle width	1786 mm/ 70.3 in
Overall height (curb condition)	1438 mm/ 56.6 in
Wheel base	2795 mm/110.0 in
Track, front	1488 mm/ 58.6 in
Track, rear	1446 mm/ 56.9 in

Main Dimensions 280 CE

Overall vehicle length	4763 mm/187.5 in
Overall vehicle width	1786 mm/ 70.3 in
Overall height (curb condition)	1395 mm/ 54.9 in
Wheel base	2710 mm/106.7 in
Track, front	1488 mm/ 58.6 in
Track, rear	1446 mm/ 56.9 in

Fuels Coolants Lubricants etc. Capacities

Vehicle components and their respective lubricants must match.

Therefore use only brands tested and recommended by us.

Enquire at your MERCEDES-BENZ service station.

	Capacity	Fuels, coolants, lubricants, etc.
Total oil capacity in case of engine oil and filter change	6.0 l/6.3 US qt	<p>Recommended engine oil</p> <p>Ambient temp. SAE grades</p> <p>°F °C</p> <p>8938</p>
Automatic transmission	Initial fill: 6.6 l/7 US qt Fluid change: 5.3 l/5.6 US qt	Automatic transmission fluid (ATF)

¹ SAE 40 may be used if ambient temperatures constantly exceed +30°C/ +86° F.

Fuels Coolants Lubricants etc. Capacities

	Capacity	Fuels, coolants, lubricants, etc.
Rear axle	1.0 l/2.1 US pt	Hypoid gear oil SAE 90, 85 W 90
Accelerator control linkage		Hydraulic fluid
Power steering	1.4 l/3.0 US pt	Automatic transmission fluid (ATF)
Front wheel hubs	60 g each, approx. 2.1 oz. each, approx.	Multipurpose grease
Grease nipples		Multipurpose or lubrication grease
Door locks		Special grease
Battery terminals		Bosch special grease
Brake reservoir	approximately 0.5 l/1.1 US pt	Brake fluid
Windshield washer system	approximately 3.0 l/3.2 US qt	Water plus windshield detergent
Fuel tank including a reserve of	approximately 80 l/21.1 US gal approximately 10.5 l/2.3 US gal	Unleaded gasoline: Average Octane of Research and Motor 87 (RON of 91)
Cooling system	10 l/10.6 US qt	Coolant

Engine Oils

Engine oils are specifically tested for their suitability in our engines. Therefore, use only engine oils recommended by us. Information on recommended brands is available at any MERCEDES-BENZ service station.

A new or reconditioned engine is filled with an initial operation oil in

the factory or in a MERCEDES-BENZ service station. This oil is specially developed for the specific operating conditions during the first 1300 – 1600 km/800 – 1000 miles.

A recommended engine oil may be used for topping up if the oil level drops to the dipstick minimum mark prior to the first service 1300 – 1600 km/800 – 1000 miles.

Brake Fluid

Brake fluid should be changed once a year, preferably in spring.

Only use brake fluid recommended by us. For further information, refer to “Safe Driving”.

Coolants

The coolant is a mixture of water and antifreeze. In production, the cooling system is filled with an anti-freeze-water mixture offering protection to approx. $-30^{\circ}\text{C}/-22^{\circ}\text{F}$. The red mark on the temperature gauge in the instrument cluster is matched to this antifreeze-water mixture (approx. boiling point $125^{\circ}\text{C}/257^{\circ}\text{F}$). The protection against corrosion is also ensured by this mixture making it unnecessary to add a corrosion inhibitor.

The coolant remains in the cooling system all year round and must be renewed after 3 years at the latest.

If coolant has leaked from the cooling system, replace the missing quantity with water and a recommended brand of antifreeze. For normal replenishment (due to evaporation of water) plain water will do.

The water should be clean, soft to medium soft and contain the minimum amount of scale forming minerals (potable water quality).

The coolant mixture should always contain enough antifreeze to ensure protection to a minimum of $-20^{\circ}\text{C}/-4^{\circ}\text{F}$.

If antifreeze is not available, add a corrosion inhibitor to the cooling water to ensure proper protection against corrosion. To treat the cooling water, do not use more than 1% ($10\text{ cm}^3/\text{l}$) of a recommended corrosion inhibitor.

Without antifreeze in the cooling system, the water already starts boiling at approx. $118^{\circ}\text{C}/224^{\circ}\text{F}$, which means that the pointer of the temperature gauge in the instrument cluster may still be below the red mark.

Antifreeze

Your vehicle contains a number of aluminum parts. The use of aluminum components in motor vehicle engines necessitates that anti-freeze/coolant used in such engines be specifically formulated to protect the aluminum parts. (Failure to use such antifreeze/coolant may result

in a significantly shortened service life.)

While there may be a number of anti-freeze/coolants available which will provide the requisite protection, all such products have not been tested for MERCEDES-BENZ vehicles. The following products, however, are deemed suitable for use in your car: MERCEDES-BENZ Anti-Freeze and Summer Coolant.

Prior to the onset of the cold season, check the coolant for its resistance to cold. Repeat this check during the cold spell. Regular testing of the antifreeze concentration is carried out only at each MERCEDES-BENZ maintenance service.

Protects up to	Antifreeze
-20°C	3.50 l
-4°F	3.7 US qt
-30°C	4.50 l
-22°F	4.7 US qt
-40°C	5.25 l
-40°F	5.5 US qt

Service-Literature

Customers who are interested in ordering service literature for their vehicles are advised to contact our subsidiaries in the U.S. or Canada at the following addresses, respectively

for U.S.A.: Mercedes-Benz of N.A. Inc.
One Mercedes Drive
P.O. Box 350
Montvale, New Jersey 07645
Att: Technical Publications
Tel: (201) 573-0600

for Canada: Mercedes-Benz of Canada
849 Eglinton Ave., East
Toronto 17, Ont., Canada
Att: Service Department
Tel: 416-425-3550

The above companies will be happy to handle any such requests from customers.

We consider this to be the best way to obtain accurate information for your vehicle.

Printed in Germany

We reserve the right to modify the technical details of the vehicle as given in the data and illustrations of this Owner's Manual (s.e.e.o.). Reprinting, translation and copying, even of excerpts, is not permitted without our prior authorization in writing.

ZKD VIII. 80. 2,5. K

- **Fuel:** Unleaded gasoline: Average Octane of Research and Motor 87 (RON of 91). Fuel tank capacity approx. 80 l/21.1 US gal, this includes a approx. 10.5 l/2.3 US gal reserve. Only fill fuel tank until the filler nozzle unit cuts out – do not over fill.
- **Engine Oil:** Check engine oil level regularly and prior to every long trip. See page 57. Quantity differential between upper and lower dipstick marking level: 1.5 l/3.2 US pt. Year-round multigrade oils 10 W–40 / 10 W–50 / 15 W–40 / 15 W–50. For further information, refer to page 74.
- **Automatic Transmission:** Automatic transmission fluid (ATF). For level checks and replenishment, refer to page 59.
- **Coolant:** For normal replenishment, use water (potable water quality). For further information (e. g. antifreeze), refer to page 77.
- **Bulbs:** High and low beams: Sealed beam/Halogen, tail and standing lamps 10 W/6 cp, turn signal, clearance and side marker lamps, front 21/5 W/32/3 cp, turn signal lamps, rear 21 W/32 cp, stop lamps 21 W/32 cp. For further information, refer to “Technical Data”.
- **Spark Plugs:** Bosch W 9 D, Beru 14–9 D, Champion N 12 Y.

- **Tire Pressure:** For driving up to 160 km/h/100 mph

Cold tires:

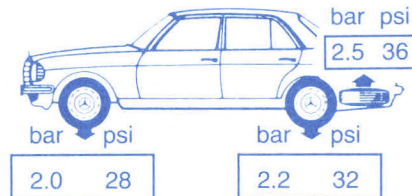

Warm tires:

Pressure may rise by up to +0.5 bar/+8 psi.
Never release any air!

For driving above 160 km/h/
100 mph
+ 0.3 bar/+ 4 psi



Mercedes-Benz
service

Daimler-Benz AG Stuttgart-Untertuerkheim Zentralkundendienst
123 584 81 97 6500 5226 USA-Ausgabe C 1981

