

Owner's
Manual

240 D
300 D
300 CD

Mercedes-Benz



1979

Owner's
Manual

240 D
300 D
300 CD

Mercedes-Benz



Rotaprintausgabe 1981

Type 123 D
1979

You have chosen to drive a MERCEDES-BENZ, a car in whose construction and production we have taken great pains because we believe that quality is not a matter of chance.

Perhaps you have already had experience with a MERCEDES, maybe this is your first car from the DAIMLER-BENZ company. In both cases — for your own benefit — please read this owner's manual before putting it away. Even though you have been driving a car for years, some things in this car may be new to you, and this manual certainly contains a few hints which will help you to make the most of your new car.

We wish you safe and pleasant motoring.

DAIMLER-BENZ Aktiengesellschaft

Contents

This Owner's Manual also describes optional extras as far as an introduction on their handling is required. As these extras need to be ordered separately, the equipment of your vehicle may deviate from the descriptions and illustrations to some extent.

The last page

What you should know at the gas station

Vehicle Operation

Instruments and Controls	8
Instrument Cluster	10
Keys, Doors	12
Master and Supplementary Keys	12
Opening, Locking and Unlocking of Doors	12
Master Lock System	13
Seats	14
Adjustment of Driver's Seat and Front Passenger Seat	14
Safety Headrest	15
Arm Rest (Rear Seat)	15
Safety Belts	16
Controls	18
Steering Lock	18
Idle Speed Adjuster	18
Light Switch	19
Combination Switch	20
Cruise Control	21
Various Equipment	22
Interior Lights	22
Rear View Mirrors	22
Sun Visor	23
Heated Rear Window	23
Shelf below Rear Window	23
Electric Lighter	24
Sliding Roof	24
Electric Window Lifters	25
Heating and Ventilation	26

Air Conditioning System	28
Automatic Climate Control	30
Radio	33

Driving

Hood	38
Regular Inspections	39
Parking Brake	40
Starting and Turning off the Engine	40
Starting and Shifting Gears	42
Manual Transmission	42
Automatic Transmission	42
Safe Driving	44
Brake Pad Wear Indicator	46
Brake Fluid	46
Charge Indicator Light	46
Oil Pressure Gauge	46
Coolant Temperature Gauge	46
Emission Control	47
Driving Economically	47
Fuel Consumption	47
Engine Oil Consumption	47
The First 1,000 Miles (1,500 km)	48
Special Operating Conditions	48
Winter Driving	48
Hints for Driving	49
High Altitude Correction Device	49
Tire Chains	49
Travelling Abroad	49

Vehicle Care		Wheels, Tires	63
MERCEDES-BENZ Main-		Changing Wheels	64
tenance System	52	Tire Pressure	65
Severe Operating		Electrical System	66
Conditions	52	Replacing Bulbs	66
Engine Oil Change and		Fuses	70
Filter Change	53	Battery	70
Automatic Transmission —		Emergency Operation of	
Fluid and Filter Change	53	Sliding Roof	71
Spare Parts Service	53	Unlocking of the Filler Flap	71
Cleaning and Care of the		Emergency-starting and	
Vehicle	54	Towing the Vehicle	72
Jobs related to Care	55	Turning off Engine Manually	73
Practical Hints		Technical Data — Fuels,	
Ash trays	58	Coolants, Lubricants, etc.	
First Aid Kit	58	Identification Plates	76
Rear Seat Cushion	59	Vehicle Data Cards	76
Spare Wheel, Jack, Vehicle		Technical Data	77
Tool Kit	59	240 D	77
Luggage or Ski Racks	59	300 D, 300 CD	79
Bleeding the Fuel System	60	Fuels, Coolants, Lubricants,	
Checking Fuels, Coolants,		etc.	81
Lubricants, etc.	60	Capacities	81
Engine Oil Level Check	60	Engine Oils	84
Replenishing Coolant	61	Brake Fluid	84
Fluid Level — Automatic		Diesel Fuels	85
Transmission	62	Coolants	86
Wheels, Tires, Changing		Service Literature	87
Wheels	63		

Vehicle Operation ▶

Driving ▶

Vehicle Care ▶

Practical Hints ▶

**Technical Data — Fuels,
Coolants, Lubricants, etc.** ▶

Vehicle Operation

Instruments and Controls

For more detailed descriptions see quoted pages.

- 1 Speaker grilles
- 2 Swivelling side ventilation outlets (page 26)
- 3 Parking brake release knob (page 40)
- 4 Hood lock release handle (page 38)
- 5 Parking brake pedal (page 40)
- 6 Combination switch (page 20)
- 7 Light switch (page 19)
- 8 Cruise control (page 21)
- 9 Idle speed adjuster (page 18)
- 10 Instrument cluster (page 10)
- 11 Horn control
- 12 Steering lock (page 18)
Steering lock with preglow/starter switch
- 13 Swivelling outlets for nonheated fresh air (page 26)
- 14 Lever for nonheated fresh air (page 26)
- 15 Switch for rear courtesy light
- 16 Switch for automatic antenna (page 35)
- 17 Air conditioner temperature switch (page 28)
- 18 Switch for electric sliding roof (page 24)
- 19 Switch for heated rear window (page 23)
- 20 Air distribution lever (page 26)
- 21 Heater switch, left vehicle side (page 26)
- 22 Switch for air volume control and blower (page 26)
- 23 Heater switch, right vehicle side (page 26)
- 24 Radio (page 33)
- 25 Ash tray with electric lighter (page 24, 58)
- 26 Speaker — fader control (page 34)
- 27 Switch group for window lifters (page 25)
- 28 Hazard warning flasher switch
Push switch = hazard warning flasher system switched on
Push switch once more = hazard warning flasher system switched off
- 29 Glove compartment, illuminated (only if steering lock is in position "1" or "2")
To open, move handle sideways

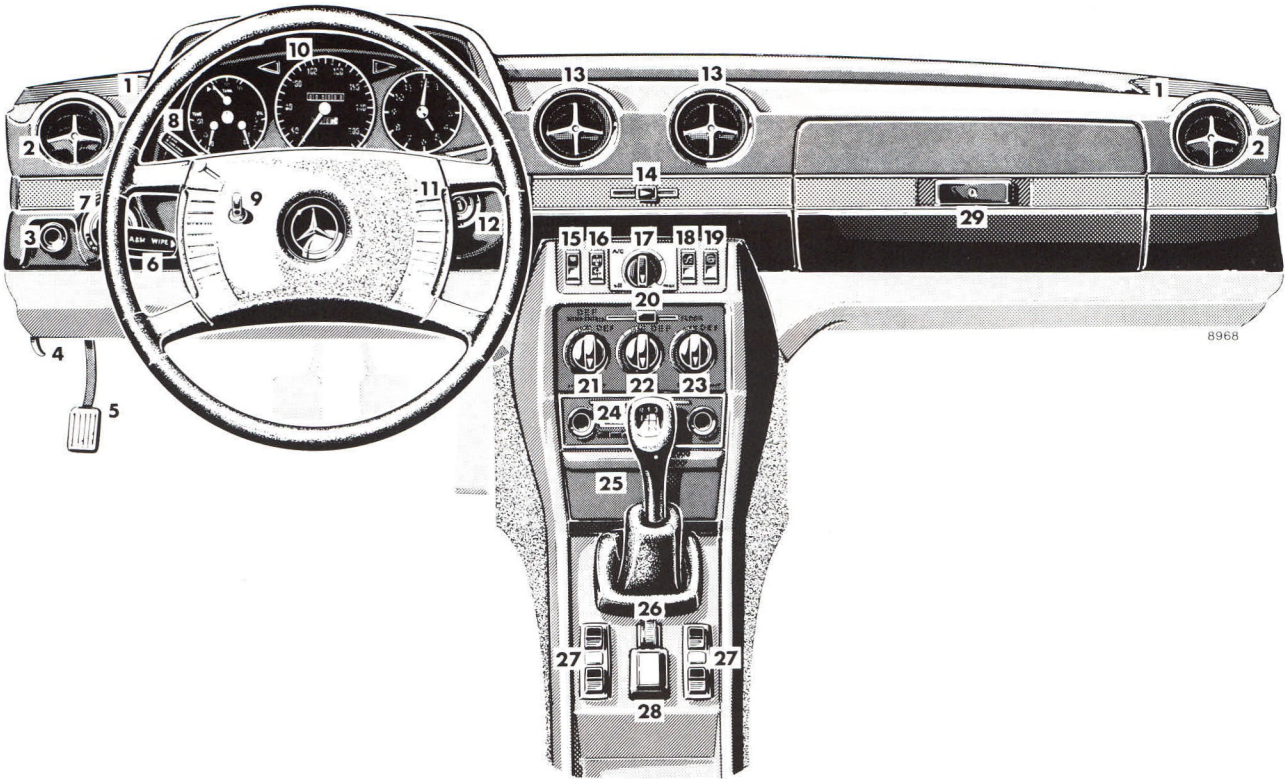

Instrument Cluster

- 1** Coolant temperature gauge (° F)
Up to red marking: Maximum permissible temperature for an antifreeze-blended fill protecting down to -22° F (-30° C)
- 2** Fuel gauge with reserve warning light (red)
Fuel reserve for approx. 35 miles (55 km)
For capacity, refer to page 83 and last page
- 3** Oil pressure gauge
- 4** Turn signal indicator light, left (green)
- 5** Main odometer
- 6** Trip odometer
- 7** Turn signal indicator light, right (green)
- 8** Electric clock
- 9** Preglowing indicator light (orange)
- 10** Seat belt warning light (red)
- 11** Knob for clock adjustment
(press in for adjustments)
- 12** Knob for instrument lighting and trip odometer
Rotate knob: instrument lighting is infinitely variable
Depress knob: trip odometer is turned back
- 13** Brake warning light (red) comes on if
 - the parking brake is engaged
 - too little brake fluid is in the reservoir
- 14** Brake pad wear indicator light (red):
Light comes on while braking and driving if the front wheel brake pads are worn down. Refer to page 46
- 15** Charge indicator light (red):
Comes on when the steering lock key is moved to driving position "2" and must go out when the engine is idling
- 16** High beam indicator light (blue)

Instrument Cluster

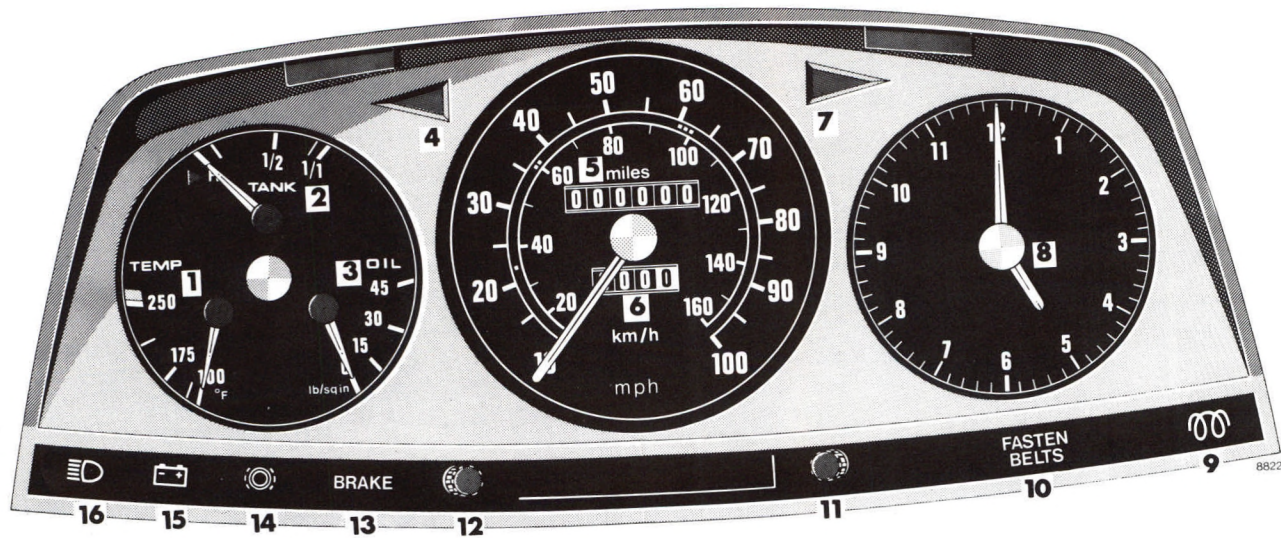

Keys Doors

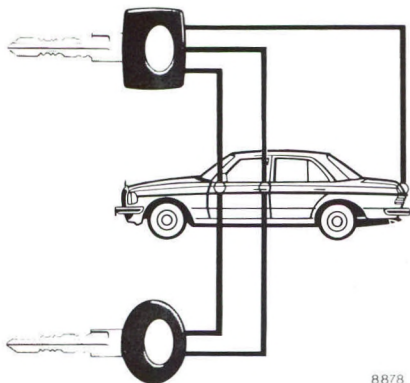

Master Key — square-headed — fits all locks on the car.

Supplementary Key — rounded head — fits only the door locks and the steering lock. This key is intended to be used whenever the car is left with an attendant. Be sure to lock glove compartment and trunk with the master key.

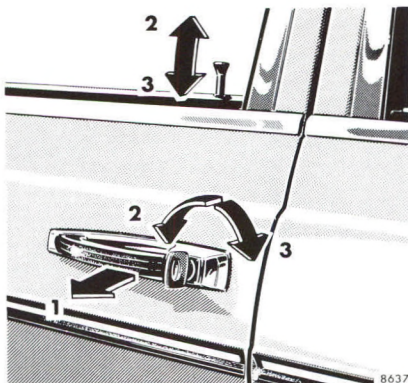

Opening the Doors

From outside: pull handle outwards (1).
From the inside: pull handle in door trim panel.

Locking and Unlocking of Doors

From the outside: turn key.
From the inside: actuate safety plunger (sedan) or safety lever (coupé).

- 2 Unlocking
- 3 Locking

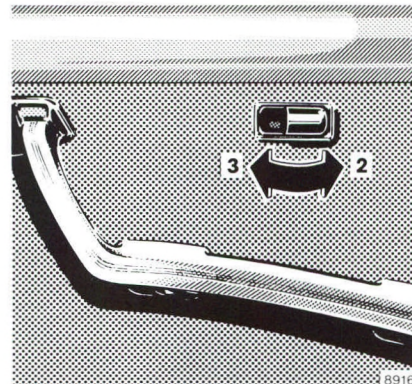

When the rear door plungers are pushed down the rear doors cannot be opened from the outside or the inside. They can be opened after pulling plungers up.

One cannot lock:

- the driver's door if it is open
- any door if the door lock has not engaged fully. In this case open the door and close it again.

Master Lock System

The master lock system simultaneously locks or unlocks together with the driver's door all other doors, fuel tank filler flap and trunk lid. As the driver's door plunger is moved, the plungers of all other doors must move at the same time. If this is not the case, the lock of the corresponding door has not engaged fully. Open the door once more and close it correctly.

When the master lock system has been applied, the lock plungers of the front passenger door and the rear doors can also be operated manually from inside. In addition to this, the front passenger door can be locked or unlocked by means of the key.

The master lock system can only be applied by depressing the plunger on the driver's door. Lock plungers of the other doors cannot be depressed individually.

The trunk lid can also be unlocked separately by turning master key

counterclockwise to the stop. Push the trunk lock button in with it and lift the lid. Return the key to its initial position and withdraw it. To lock the lid, close it firmly. It will then be locked again by the master lock system.

A provision has been made to facilitate permanent locking of the trunk lid for positive prevention of access to trunk by unauthorized persons.

Before leaving vehicle with an attendant, lock trunk with master key (square head) by turning key clockwise to stop (tumbler slot vertical), then provide attendant with round-headed supplementary key. Thus, the trunk lock has been excluded from the operation of the master lock system and cannot be opened except with the square-headed master key.

To reverse this, turn trunk lock counterclockwise back to horizontal position of the tumbler slot with master key. Lock will then be

reengaged in master lock system; that is, it will automatically be locked or unlocked depending on whether the driver's door is locked or unlocked.

The master lock system operates on vacuum generated by the engine. A reservoir allows the master lock system to be actuated about five times after the engine is turned off. If the system can then no longer be engaged, idle engine for a short period.

If no vacuum is available, doors and trunk have to be locked individually in the normal manner. The fuel tank filler flap, however, remains unlocked.

Note:

If the filler flap cannot be opened when the master lock system is unlocked, refer to "Unlocking of the Filler Flap" (page 71).

Seats



8665

Adjustment of Driver's Seat and Front Passenger Seat

Forward and backward adjustment: lift handle (1); slide seat to desired position and allow handle to re-engage.

Height of seat: raise lever (2); to raise seat, move seat forward; to lower seat, move seat backward; allow lever to re-engage.

Seat back position: turn hand-wheel (3) forward or backward. For full reclining of backrest, seat

should be moved to one of the forwardmost positions and headrest removed. For driving, return backrest to upright position and push seat back. Replace headrest.

Note:

Prior to operating the vehicle, the driver should adjust the seat height for proper vision as well as fore-aft placement and seat back angle to insure adequate control, reach, operation, and comfort. The headrest should also be adjusted for proper height so that when the cushion is tipped completely forward, it should form a cradle behind the seat occupant's head. Both the inside and outside rear view mirrors should then be adjusted for adequate rearward vision. Fasten seat belts. Children under the age of six or under the weight of 50 lbs. (23 kg) should be seated in the back seat with an approved restraint system properly secured. All seat, headrest, and rear view mirror adjustments as well as fastening of seat belts should be accomplished before the vehicle is put into motion.

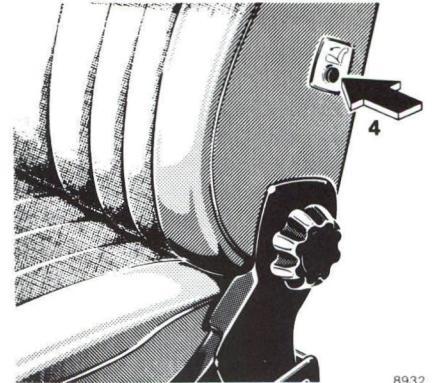

8932

Coupé: When the doors are closed the backrests are locked by means of vacuum. The locks can be released by pushing button (4). When the doors are opened the backrests can be folded forward readily.

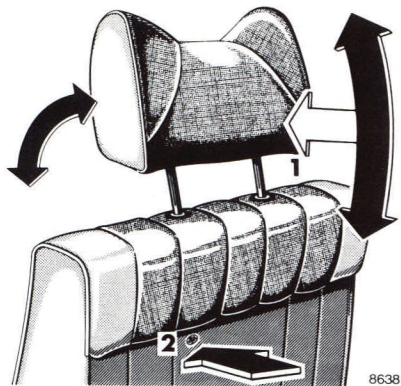

Safety Headrest

Adjust headrest to support the back of the head at the level of the upper end of the ear.

Height adjustment:

Press headrest slightly forward (1) and reset upward or downward.

Detaching headrests:

Pull headrest out to the stop. Release arrester by depressing locking knob to be felt under the backrest covering material and pull up headrest, holding it by the LH headrest post (viewed in driving direction). Finally pull out headrest completely with both hands.

The headrest locking knob of the front seat is located below the LH headrest post (2).

The headrest locking knob of the rear seat is located between the two headrest posts.

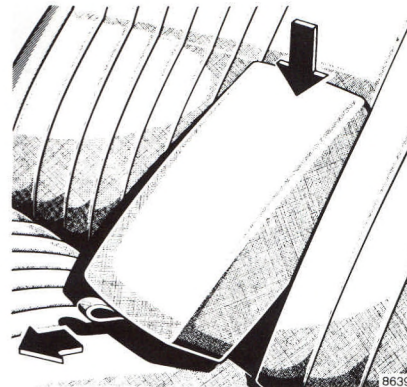

Arm Rest (Rear Seat)

A center arm rest is provided in the rear seat which can be pulled out with a loop.

When replacing, lift at the rear.

For the removal of the rear seat cushion see "Practical Hints".

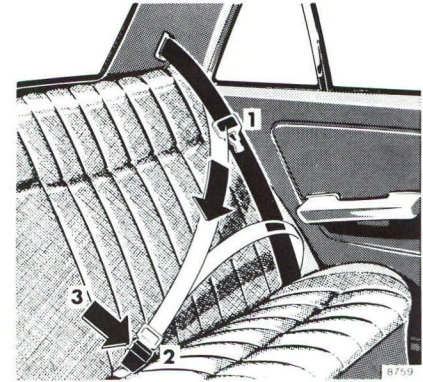
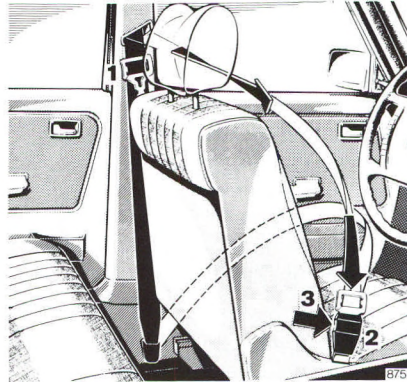

Safety Belts

Warning system:

The indicator marked "FASTEN SEAT BELTS" is illuminated for 4 – 8 seconds after turning the steering lock key to position "2". If the safety belt of the driver's seat is not fastened a warning buzzer sounds simultaneously.

Fastening of front and rear outer seat belts (with inertia reel):

- Pull belt with tongue (1) across shoulder and lap. The belt must not be twisted and must be tight.
- Press tongue (1) into buckle (2) and allow to engage audibly.

Unfastening, front and rear:

- Depress red button "PRESS" (3) in buckle (2).
- Return tongue (1) to initial position.

Fastening of rear center belt (without inertia reel):

- Pull belt across the lap. It must not be twisted and must be tight.
- Press tongue into buckle and allow to engage audibly.

Adjustment of rear center seat belt:

To lengthen, turn belt buckle (on LH side of belt) to be at right angles to the belt and pull the tongue.
To shorten, pull loose end of belt.

Operation of belts with inertia reel:

The safety belt inertia reel stops the belt from unwinding further in case of vehicle deceleration in any direction or if the belt is pulled out quickly.

Functional test:

The locking function of the inertia reel can be tested by braking, driv-

ing around a bend or by pulling the belt out quickly.

Note:

No safety belt can be used for more than one person. Belts are not intended for children.

After an accident, inspect the safety belts and replace them, if re-

quired. The belt anchors in the vehicle should also be checked.

Belt webbing must not be routed via sharp edges.

No modifications which may affect the efficiency of the belts must be made.

For cleaning and care of belt webbing, refer to page 55.

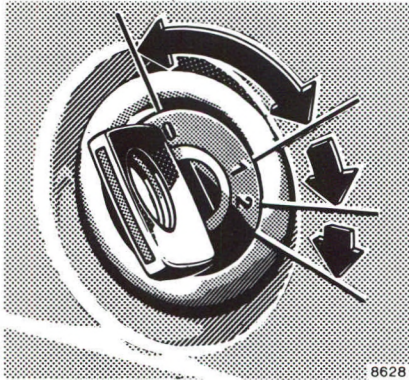

Steering Lock

- 0 Steering is locked when the key is removed. Key can be removed only in this position.
Note:
Do not remove key from steering lock while the vehicle is in motion as this will cause the engagement of the steering lock thus rendering the vehicle inoperable.
- 1 Steering is unlocked.
(If necessary, move steering wheel slightly to turn the key clockwise to position "1".)

- 2 Preglowing and driving position. Starting: continue turning key clockwise to the stop. The starter is engaged when the key is pressed against the stop. The starter nonrepeat unit requires the key to be returned to position "0" prior to a new starting attempt. For starting and turning off the engine, refer to page 40.

Notes:

The following items can be operated with the key in steering lock position "1":

Wiper, windshield washer, headlight flasher, electric lighter, glove compartment light, radio, electric seat heater for front seats.

The power supply to the standing lights is disrupted if the key in the steering lock is in position "2".

A warning buzzer sounds when the key has been left in steering lock positions "1" or "0" and the driver's door is opened.

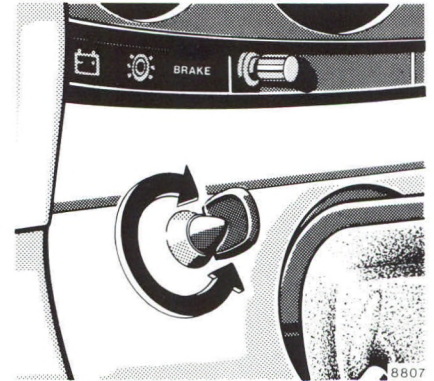

Idle Speed Adjuster

- To increase idle speed, turn knob counterclockwise.
- To decrease idle speed, turn knob clockwise.

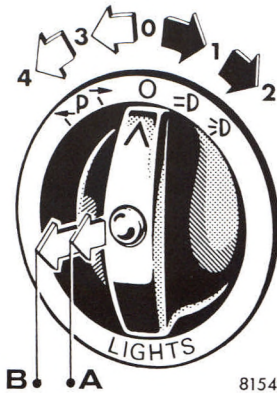

Light Switch

- 0 Off-position
- 1 Parking lights (includes side marker lights, tail lights, license plate lights, instrument panel lights)
- 2 Same as pos. 1 plus headlights

- 3 Standing lights, right
- 4 Standing lights, left
- A Turn to position 2 and pull out to first detent = same as position 2 plus fog lights
- B Available for an option

Note:

With the steering lock key removed and the driver's door open a signal sounds if the vehicle's exterior lighting is not switched off (standing lights excepted).

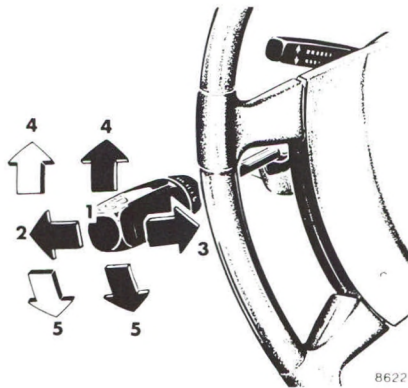

Combination Switch

- 1 Low beam (turn light switch clockwise two notches)
- 2 High beam (turn light switch clockwise two notches)
- 3 Headlight flasher (high beam available independent of light switch position)
- 4 Turn signals, right
- 5 Turn signals, left

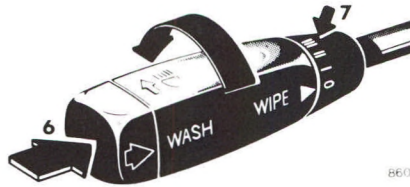

- 6 Control for windshield washer system
When the washer system is switched on, the wipers also operate
- 7 Windshield wiper speeds
 - 0 Windshield wiper switched off
 - I Intermittent wiping
 - II Normal wiper speed
 - III High wiper speed

Hints:

If one of the turn signals fails, the turn signal indicator system flashes and sounds at a faster sequence than under normal operating conditions.

Fog lights will only operate together with low beam headlights. Fog lights are turned off automatically when light switch is returned to off-position.

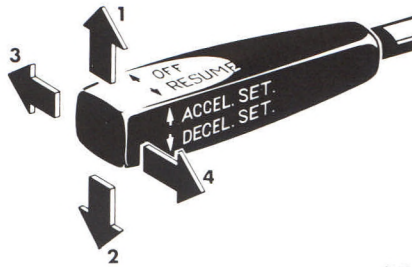

8623

Cruise Control

Any given speed above a range of approximately 10 – 25 mph (16 – 40 km/h), depending on model, can be maintained with the cruise control by operating the switch.

- 1 = Setting (touch switch)
Accelerating (hold switch)
- 2 = Setting (touch switch)
Decelerating (hold switch)

Normally the vehicle is accelerated to the desired speed with

the accelerator. Speed is set by briefly pushing the switch to position "1" or "2", and the accelerator can be released. The speed can be increased (e. g. for passing) by using the accelerator. As soon as the accelerator is released, the previously set speed will be resumed automatically.

If the set speed is to be increased or decreased slightly (e. g. for adaption to the flow of traffic), hold switch in position "1" or "2" until the desired speed is reached. When the switch is released, the newly set speed remains constant.

- 3 = Cancelling
To cancel the cruise control, briefly push lever to position "3".
The cruise control will also be cancelled if the brake pedal is actuated or if the vehicle speed drops on steep grades by more than 20 % below the set speed.

- 4 = Resume
If the lever is briefly pushed to position "4" when driving at a speed exceeding approximately 10 – 25 mph (16 – 40 km/h), depending on model, that speed is resumed which was set prior to the cancellation of the cruise control. The last memorized speed is cancelled when the key in the steering lock is turned to position "1" or "0".

Important:

Please do not use the cruise control if traffic conditions do not make it advisable to maintain a steady speed, i. e. in heavy traffic or on twisting or slick and muddy roads.

Position "Resume" should be engaged only if the driver is fully aware of the previously set speed and wishes to resume this particular preset speed.

When driving with the cruise control, the selector lever must not be shifted to position "N" as otherwise the engine will overrev.

Various Equipment

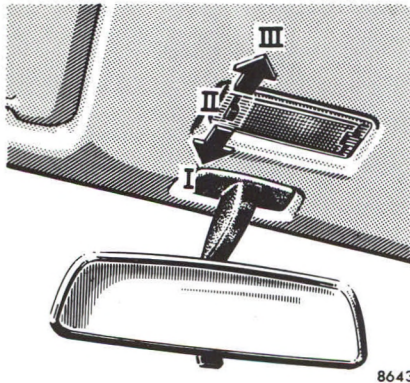

Interior Lights

The switch for the front light has 3 positions.

Position I: light is switched on and off by the front door contact switches.

Position II: light is continuously switched off.

Position III: light is continuously switched on.

The rear passenger compartment light is switched on and off by the

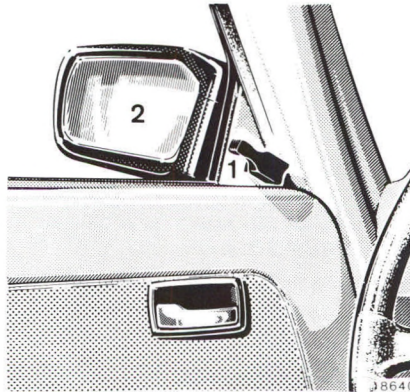

rear door contact switches or by the rocker switch on the instrument panel.

Rear View Mirrors

Outside rear view mirror:

Outside rear view mirror (2) can be randomly adjusted from inside by means of lever (1). If the mirror housing has been forcibly removed from its safety catch, it must be repositioned by applying firm pressure.

Inside rear view mirror:

Mirror housing can be randomly adjusted. In addition mirror can be dimmed by means of lever on lower mirror edge. Lever in opposite driving direction = normal position. Lever in driving direction = anti-dazzle position.

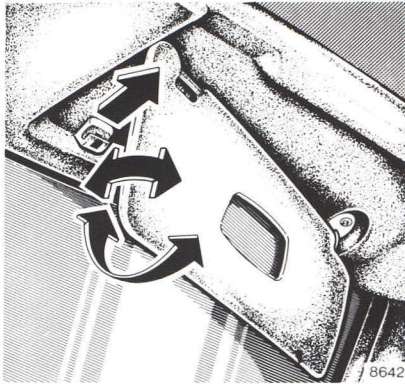

Sun Visor

To protect against sunlight from ahead, fold the sun visor downwards.

In the event of strong sunlight through the side windows, remove the sun visor from its inner fixture and swing it sideways.

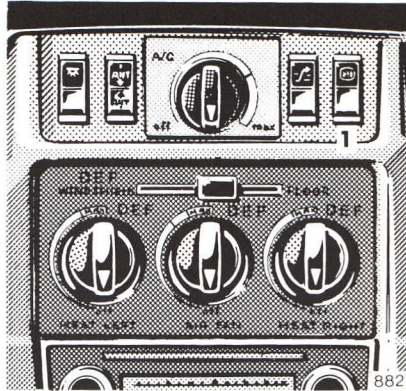

Heated Rear Window

Turn key in steering lock to position "2".

When the rear window heater is turned on, the white indicator light in the switch (1) comes on.

A heavy load is imposed on the battery due to the high power re-

quirement. For this reason, switch off the heated rear window as soon as it is demisted or defrosted. It is shut off automatically after a maximum of 30 minutes. Always remove heavy layers of ice and snow first.

Shelf below Rear Window

Do not carry heavy or hard objects on the shelf below the rear window. Such items could become dislodged during hard braking or upon a vehicle crash causing distraction or serious injury to the vehicle occupants.

Various Equipment

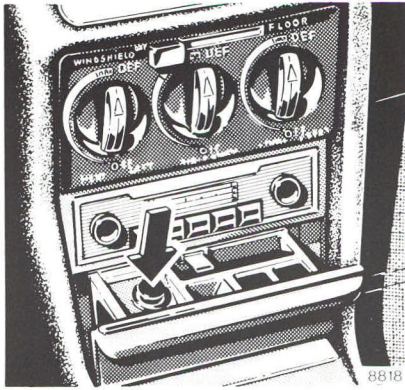

Electric Lighter

Key in steering lock position "1" or "2".

Press in electric lighter; it will pop out automatically when hot.

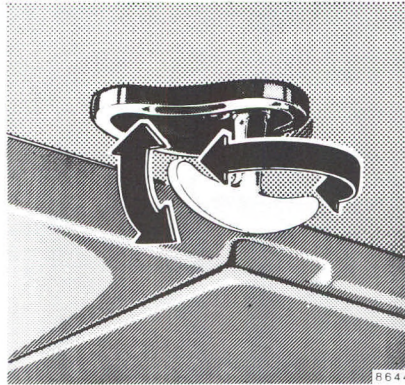

Sliding Roof

Manual operation

To release, swing down locking lever and turn by half a revolution to the stop. Slide roof to the desired position. To secure, turn back the locking lever to the stop and swing up.

Note:

For safety reasons the locking lever must be swung up every time the sliding roof was moved.

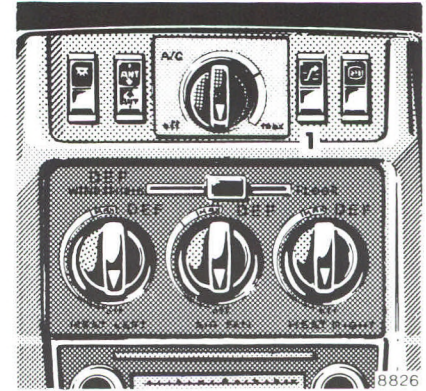

Electrical control

Turn key in steering lock position "2".

Press upper end (symbol) of rocker switch (1) to open roof, press lower end to close.

If the electric drive fails, the sliding roof can also be moved by hand. Refer to "Emergency Operation of Sliding Roof".

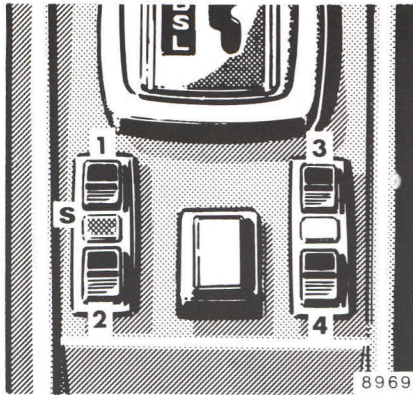

Electric Window Lifters

Switch group for window lifters:

- 1 front, left
- 2 rear, left
- 3 front, right
- 4 rear, right
- S Safety switch

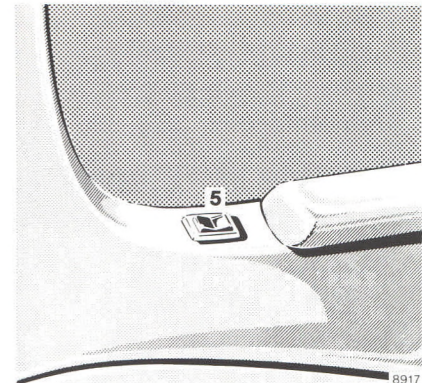
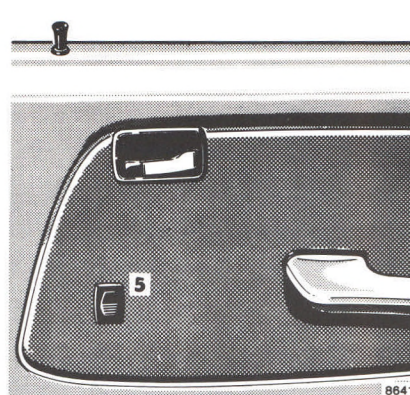

The electric window lifters can only be operated with the steering lock in position "2". All four windows can then be operated using the switches in the center console. The rear door windows can also be operated using the switches (5) in

each rear door panel as long as the safety switch "S" in the center console is depressed. If the safety switch is not depressed, inadvertent operation of the rear door windows (for instance, by children) is prevented.

Heating and Ventilation

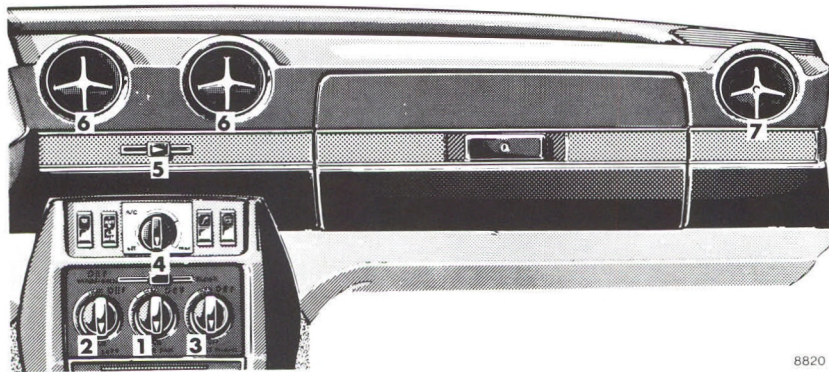

1 Air volume control knob

Switch on by turning clockwise. The air volume is then increased up to the stop. The 3-speed blower cuts in as of scale mark "I".

In case of dust and fume annoyance from outside, the air supply to the vehicle can be cut off (by turning knob counter-clockwise to the stop).

To heat and ventilate the parked vehicle, or if an in-

sufficient volume of air is available during the ride, move air volume control knob at least to blower speed I. For fast touring we recommend you to engage blower speed I, for city traffic speed II.

2 Heater knob, left vehicle side

3 Heater knob, right vehicle side

Switch on heater by turning to the right. Heating power is then increased up to the stop.

Control air volume with knob 1.

4 Air distribution lever

Lever to the left = air to windshield

Lever in center position = air to windshield and to front and rear footwells

Lever to the right = air to front and rear footwells and a minor volume of air to the windshield

5 Lever for nonheated fresh air

Lever to the left = open

Lever to the right = closed

6 Swivelling outlets for non-heated fresh air

7 Swivelling outlets for side ventilation

Turn right = open

Turn left = closed

Fresh air enters the vehicle through the openings in front of the windshield (keep free of snow) and is emitted through the ventilation openings below the rear window if the side windows are closed. Do not cover up ventilation openings with clothes etc.

Examples for heating and ventilation settings

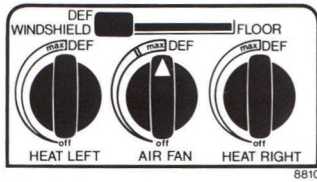

Maximum heating power and maximum air volume to the windshield (DEF = Defrost). To defrost the side windows, also open swivelling outlets 7 and point towards the side windows.

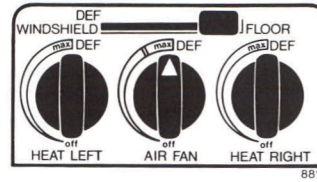

Maximum heating power and maximum air volume to front and rear footwells.

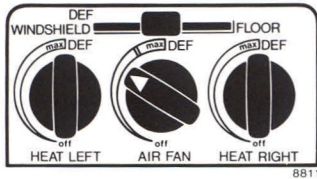

Maximum heating power and normal air volume to the windshield as well as to front and rear footwells.

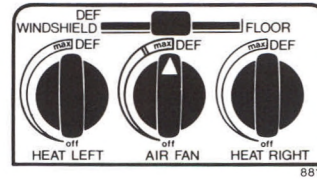

Maximum air volume to windshield as well as to front and rear footwells (open lever 5 fully for nonheated fresh air).

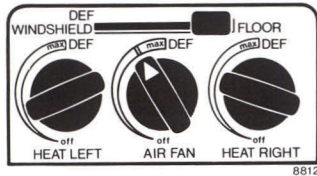

Varying heating power and increased air volume to front and rear footwells, left and right vehicle side.

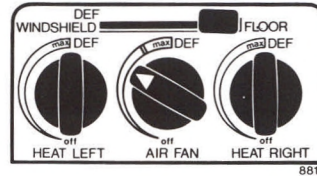

Normal air volume to front and rear footwells (open lever 5 halfway for nonheated fresh air).

Air Conditioning System

The temperature inside the vehicle can be lowered by means of the air conditioning system. When temperature switch 8 is switched on, the air is passed over an evaporator and is thus cooled and dehydrated at the same time.

The air is circulated by a blower and may be distributed according to preference by means of the ventilation system controls.

The air conditioning system is operative only when the engine is running. High engine speed produces a high refrigerant compressor speed which in turn means increased cooling.

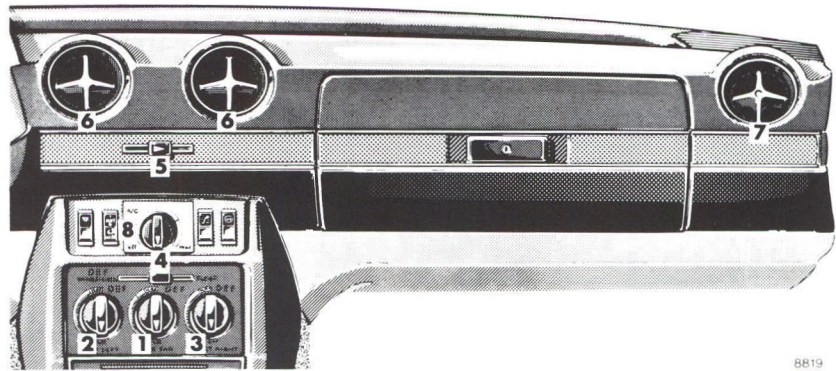

- 8 Temperature switch. Switch on by turning to the right. The cooling effect is increased up to the stop. After $\frac{2}{3}$ of the switch travel, the system changes over from fresh air cooling to recirculation air cooling with a small proportion of fresh air.

The blower (switch 1) must then be switched on. We re-

commend selecting a higher blower speed for increased cooling effect.

By pulling the temperature switch cooled air may also be passed to the footwell.

Note:

In case of dust and odor annoyance from outside, turn temperature switch to recirculation cooling with a small proportion of fresh air.

8819

Rapid cooling:

- Turn temperature switch 8 (depressed) and air volume control knob 1 clockwise to the stop.
- Push lever 4 completely to the right and lever 5 completely to the left. Open outlets 7.
- Close side windows completely. (Warm air inside the car may first be evacuated by driving briefly with all the side windows down.)

Mist on outside of windshield:

In damp weather the outside of the windshield may fog. In this case, turn lever 4 to the right. Less cooled air is then supplied to the windshield.

Mist on inside of windows:

In damp weather the air conditioning system can be switched on in addition to the heater. Moisture is then extracted either from the fresh air or from the recirculation air, depending upon the setting of temperature switch 8. This cooled and dehydrated air can be reheated to a pleasant temperature by positioning heater controls 2 and 3 accordingly. This action quickly dries up the windows.

Important!

In order to keep the air conditioning system in good working condition at all times, it is necessary to operate the system briefly at least once a month even during the seasons it is normally not required. Make sure that the ambient temperature is above 36° F (2° C) since the A/C compressor will not operate below this temperature. To avoid annoying cold air, switch blower to the lowest speed only and turn on the heater, if desired.

Automatic Climate Control

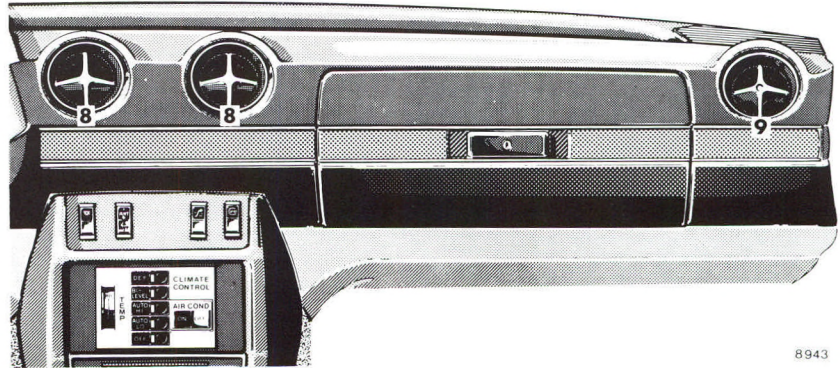
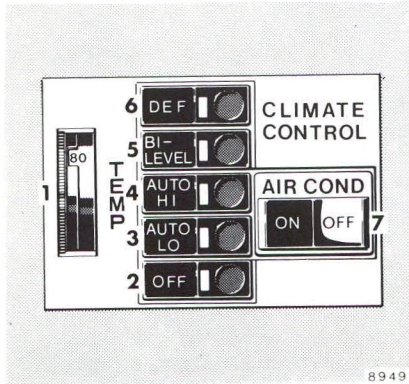

- 1 Temperature selector wheel
- 2 "OFF" button
- 3 "AUTO-LO" button
- 4 "AUTO-HI" button
- 5 "BI-LEVEL" button

- 6 "DEF" button
- 7 Refrigerant compressor switch
- 8 Swivelling outlets for cooled air
Turn right = open
Turn left = closed

- 9 Swivelling outlets for side ventilation
Turn right = open
Turn left = closed

The automatic climate control is designed to maintain the desired temperature in the vehicle interior. Heating, cooling and air distribution (top, center, bottom) are controlled automatically. The blower speeds will be varied automatically depending on the push button setting, operating and temperature conditions.

The automatic climate control is operational only if the engine is running.

For adaptation to the weather conditions various functions can be selected with the pushbuttons. Air outlets 8 — 9 must then be adjusted as required. Buttons 2 — 6 can be pressed only individually. The indicator lights in the individual buttons come on if the buttons are pressed and the vehicle lighting is switched on.

- 1 Temperature selector wheel
The desired temperature in the vehicle interior can be set with the selector wheel.

Normally only one adjustment is necessary for the entire year. If required to be altered, only slight adjustments should be made to this temperature setting.

- 2 "OFF" button:

Switching off the automatic climate control.

Simultaneously the fresh air supply to the vehicle interior is cut off. This position can be briefly selected in the case of odorous or dust annoyances or when passing through an automatic car wash.

- 3 "AUTO-LO" button:

Normal vehicle operation.

This setting will provide heating or cooling of the vehicle's interior depending on the selector wheel setting and the outside temperature. If heating is required, the fresh air supply and the blower will remain in the off position until the

engine cooling water is slightly warmed up. Only then will warm air enter the interior of the vehicle and be distributed mainly to the footwell outlets. A small amount of air is directed to the windshield to ensure defogging under normal weather conditions. For the defogging of the side windows, air can be diverted from the side outlets 9. The center outlets 8 remain closed during heating operation.

If cooling of the interior is required, the blower will start immediately regardless of engine temperature. The air is routed via center outlets 8 into the vehicle's interior and additionally via the side outlets 9. No air is allowed to flow to the windshield and to the footwell. The blower speed will be automatically reduced in several steps in the heating or cooling cycle as the interior temperature approaches the pre-selected temperature on the temperature wheel 1.

Automatic Climate Control

4 "AUTO-HI" button:

Fast heating or cooling of vehicle interior.

Air conditioning, air distribution and blower control are the same as in position "3" "AUTO-LO". The blower, however, operates at a higher speed.

5 "BI-LEVEL" button:

For fogged-up windows.

During heating and cooling operations air is channelled to the windshield and to the footwell. During the cooling operation air also enters via the center swivelling outlets 8.

The vehicle interior is cooled practically free of draft with more air being blown into the footwell. The blower then operates at a higher speed than "AUTO-LO".

We recommend this position at low ambient temperatures.

6 "DEF" button:

For iced-up windows.

Independent of the position of the temperature selector wheel air heated to maximum temperature is channelled to the windshield.

For the side windows, open swivelling outlets 9.

7 Refrigerant compressor switch:

Switching the air conditioning compressor on and off.

The compressor can be switched off completely in the positions "AUTO-LO" and "AUTO-HI", e.g. if no cooling is required because of low ambient temperatures (fuel economy).

Fresh air is supplied to the footwell if the refrigerant compressor is switched off while the system is working in the cooling mode.

Fresh air enters the vehicle through the openings in front of the windshield (keep free of snow) and is emitted through the ventilation openings below the rear window if the side windows are closed. Do not cover up ventilation openings with clothes etc.

Important!

In order to keep the air conditioning section of the climate control system in good working condition at all times, it is necessary to operate the A/C compressor briefly at least once a month even during the seasons it is normally not required. Switch compressor switch to "ON" and depress "AUTO-LO" or "AUTO-HI" button. Make sure that the ambient temperature is above 36° F (2° C) since the A/C compressor will not operate below this temperature.

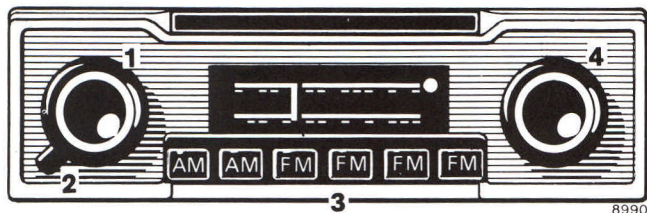

Europa
(Radio with Pushbutton Tuning)

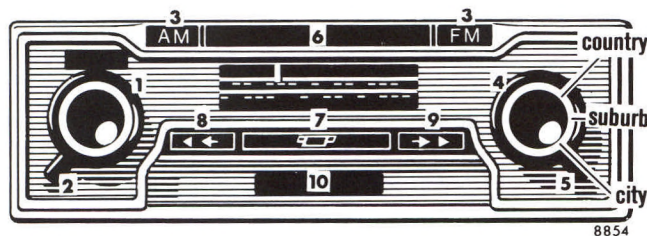

Mexico Casette
(Radio with Automatic Signal Seeker
and built-in Cassette Player)

- 1 On-Off/Volume Control
- 2 Tone Control
- 3 Push buttons for band selection and tuning of preset stations (band selection only on radios with built-in cassette player)
- 4 Manual tuning control
- 5 Search sensitivity switch
- 6 Automatic tuning bar (Mexico models only)
- 7 Cassette release
- 8 Fast forward
- 9 Fast rewind
- 10 Cassette slot

For control location, refer to the illustration on the type of radio installed in your MERCEDES-BENZ. The radio can only be operated with the ignition key in the number "1" or "2" position.

Radio

On-Off/Volume

Turn knob (1) clockwise to switch radio on and to increase volume. Green control light on the dial will light up.

Tone

Turn lever (2) clockwise to increase treble range and counterclockwise to increase bass range.

Front-Rear Speaker Balance

This control is installed whenever the vehicle is equipped with rear speakers. Turn rearward to increase volume of rear speakers and forward to increase volume of front speakers.

Station Tuning

First, select desired band by pressing one of the AM or FM station buttons (3), then tune manually by turning control knob (4). For good reception, accurate manual tuning is important.

To preset stations on pushbutton tuning radios in either the AM or FM band, pull station buttons (3), carefully tune in the desired station, push button slowly and firmly all the way in, then release.

Automatic station tuning (on signal seeking radios only) is accomplished by momentarily depressing the "Automatic Tuning" bar (6). The tuner moves from the left towards the right side of the dial and stops whenever a useable station is found.

Operating the automatic tuning bar again causes the tuner to resume its search function. When the end of the band is reached, the tuner will automatically return to the beginning of the band and start the search operation again.

The position of the search sensitivity switch (5) determines whether the tuner will stop at many or the most powerful stations only.

- | | |
|--------------|--|
| Position I | Selector stops at every "country" useable station |
| Position II | Selector stops only at "suburb" more powerful stations |
| Position III | Selector stops only at "city" the strongest stations |

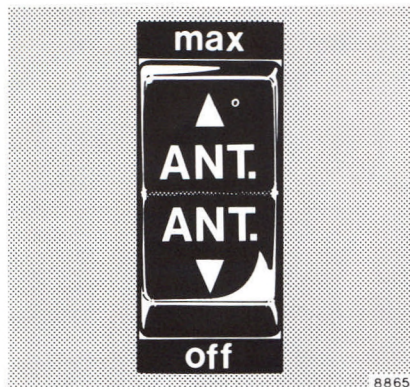

Automatic Antenna

The antenna switch can be actuated with the radio switched on and the key in steering lock positions "1" or "2".

- If the antenna switch is in center position, the antenna extends automatically to a specific height,
- if the antenna switch is engaged in the "max" position, the antenna extends fully,

- if the antenna switch is engaged in the "off" position, the antenna will not extend or will retract completely.

The height of the antenna can furthermore be adjusted continuously by actuating the antenna switch:

- If the antenna switch is in center position, the antenna will extend to the specific height. The antenna can be further extended or retracted to any height by rocking the switch (not engaging it).
- If the antenna is to be retracted, e. g. for playing cassettes, engage switch in "off" position.

When the key is turned to steering lock position "0" or the radio is turned off, the antenna will retract completely.

FM Reception

FM signals travel in a "line-of-sight". Reflections or "dead spots" may cause cancellations or loss of

the signal as well as strong signal overloading or capture.

Lowering the antenna height in strong signal areas may eliminate many of the resulting problems and restore good tone quality. However, fringe area reception requires the full antenna length to capture weak incoming signals. The antenna can be operated by depressing the respective side of the rocker switch.

FM Stereo Reception

When tuned to a FM stereo station, the red Stereo Indicator Light will light up. Because more information is carried in the FM stereo signal than in FM monoraul broadcasts, flutter, cancellation and capture effects may be even more noticeable. The noise-free broadcast range, therefore, is somewhat less and accurate tuning to the strongest available stereo stations is required, especially for fringe area reception.

Radio

Your radio is equipped with a specially designed Stereo Decoder which automatically switches the radio from stereo to mono reception if the signal becomes too weak. However, the Stereo Indicator Light remains lit to avoid the distracting flicker at short-time signal changes. The radio will return to the stereo mode automatically when signal strength permits it.

Tape Playback (Mexico Cassette Model)

This type of radio provides for the playback of prerecorded stereo

music through the unique combination of all the features of an automatic signalseeking stereo radio with a tape player.

To start playback, insert stereo cassette through the swing-away door of the cassette slot and depress until the mechanism engages. (Note: Full reel on the right tape side of cassette first.) The cassette will be automatically released when the tape reaches its end. To play the other side, remove the cassette from the radio, turn it upside down and reinsert through the slot. To manually eject the cassette, push the release bar (7).

When the cassette is ejected, the unit will automatically switch to radio reception.

For fast forward or rewind of the tape, depress button 8 or 9 past point of resistance. To stop tape winding, depress opposing button to point of resistance only.

Care of the Tape Player

Use only good quality cassettes with a maximum playing time of 45 minutes per side (C 90). "Unwound" tapes can be fixed by rewinding either reel with a pencil inserted in its hub. The pick-up head and roller should be cleaned occasionally to maintain the original high quality sound reproduction.

Driving



Hood

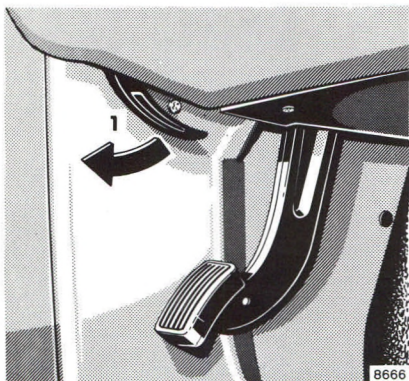

To open:

Pull lever (1) under the LH side of the instrument panel to unlock the hood. The hood opens to the safety catch stop. At the same time grip (2) will pop out of the radiator grille.

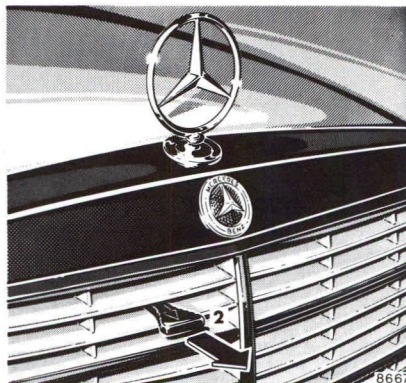

Pull grip (2) out of the radiator grille as far as the stop and lift up hood (windshield wiper arms must not be folded out).

Closing:

Close hood by depressing it firmly.

Note:

There is a risk of injury when the hood is open and the engine is running.

Have the following items checked regularly and prior to any long trip

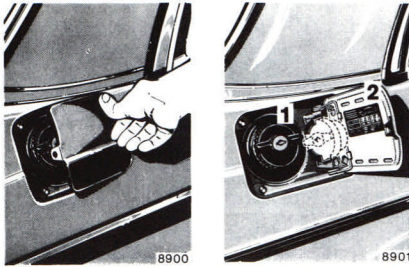

1 Fuel Supply

For winter and summer operation diesel fuels refer to "Fuels, Coolants, Lubricants, etc. and last page".

2 Tire Pressure

For tire pressure table refer to fuel filler flap or last page. Check at least every other week. For further information see "Wheels, Tires, Changing Wheels".

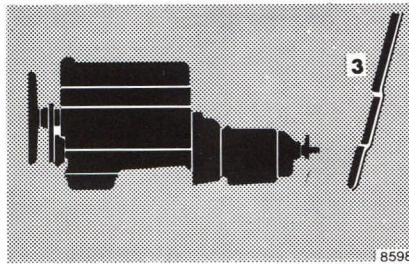

3 Oil/Fluid Level: Engine, Automatic Transmission

See "Checking Fuels, Coolants, Lubricants, etc.", "Fuels, Coolants, Lubricants, etc. and last page".

4 Coolant Level

See "Checking Fuels, Coolants, Lubricants, etc.", "Fuels, Coolants, Lubricants, etc. and last page".

5 Brake Fluid

When the minimum mark on the reservoir is reached, have the system checked (brake lining thickness, leaks).

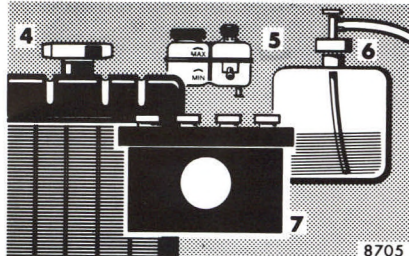

6 Windshield Washer

Replenish with water mixed with windshield washer detergent (container is in the engine compartment).

7 Battery

Replenish with distilled water only. See "Electrical System".

Vehicle Lighting

Check for function and cleanliness.

Parking Brake

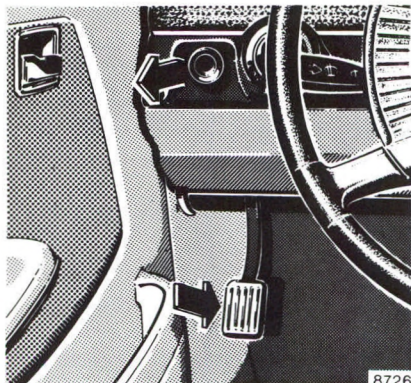

Depress parking brake pedal. When the steering lock key is in position "2", the brake warning light in the instrument cluster comes on.

To release, pull release button on the instrument panel. The parking brake releases in one rapid movement. The parking brake warning light in the instrument cluster must go out.

Starting and Turning off the Engine

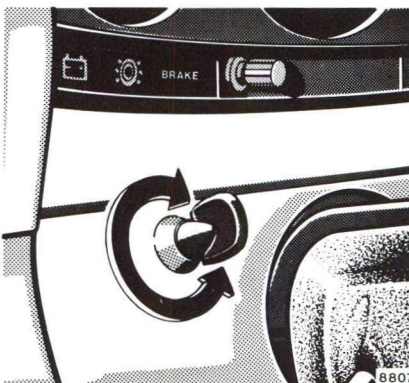

Engage parking brake or service brake before starting the engine.

Move gearshift lever to neutral (selector lever positions "P" or "N" on automatic transmissions).

Depress accelerator halfway and turn idle speed adjuster counterclockwise to the stop. Then release accelerator.

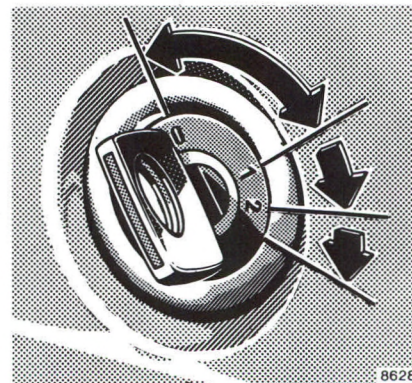

Turn key in steering lock to position "2". Charge indicator and preglowing indicator light must come on.

The preglowing process then begins. The engine can be started as soon as the preglowing indicator light has gone out. Since the glow plugs continue glowing for up to 1.5 minutes, the engine can be restarted during this period without preglowing again.

When the engine is at operating temperature (coolant temperature above approx. 158° F = 70° C) the preglowing indicator light comes on only briefly. The engine can be started immediately.

Turn key clockwise to the stop to start the engine. Release key only when the engine is running smoothly.

At ambient temperatures of less than -4° F (-20° C), depress the accelerator three times prior to starting.

At ambient temperatures below +59° F (+15° C) and with the engine cold, depress accelerator at least half of its travel while starting.

At ambient temperatures below +23° F (-5° C) and with the engine cold, depress clutch pedal completely and the accelerator at least half of its travel while starting.

If the engine has not started after approx. 20 secs, discontinue the

starting procedure and return key to position "0".

This need not be done if the engine has started firing. The starter may then be engaged even longer. Do not exhaust battery.

After an unsuccessful starting attempt, repeat the entire starting procedure.

When the engine has started firing, adjust idle speed as follows:

- Ambient temperature below +59° F (+15° C) and engine cold: Turn idle speed adjuster knob clockwise until the engine just runs smoothly.
- Ambient temperature above +59° F (+15° C): After approx. 10 secs, turn idle speed adjuster knob clockwise to the stop.

With the engine at operating temperature the idle speed adjuster knob should be returned clockwise to the stop (normal position).

Observe the oil pressure gauge immediately after starting the engine. In a very cold engine the oil pressure will only rise slowly, some time after the engine has started. Do not speed up the engine before pressure is registered on the pressure gauge.

The charge indicator light must go out as soon as the engine has started.

Turning off

Turn key in steering lock to position "0" and remove only when the vehicle has stopped.

Should the engine continue to operate in steering lock position "0", refer to page 73.

With very high coolant temperatures (e.g. after driving on steep inclines), do not shut down the engine immediately but allow to run at slightly increased idle speed for another 1 – 2 minutes approximately.

Starting and Shifting Gears

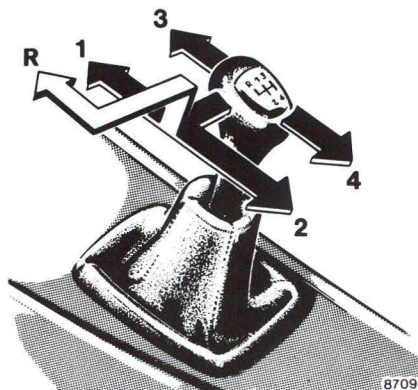

Do not store any objects in the driver's footwell area because they could become lodged under the operator's pedals thus rendering these controls partially or totally inoperative.

Test the service brake shortly after driving off.

Warm the engine smoothly. Do not place full load on the engine until the operating temperature has been reached.

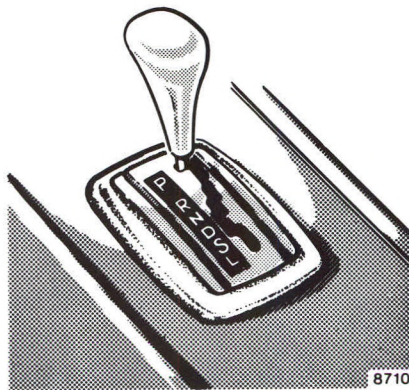

Manual Transmission

See figure for gearshift lever positions corresponding to the individual gears.

Engage reverse gear only with the vehicle at standstill; pull up gearshift lever and engage reverse gear shortly after declutching.

Do not exceed the maximum speed in the individual gears. See line markings on the speedometer.

Note:

When parking the vehicle, engage 1st or reverse gear and depress parking brake pedal.

Automatic Transmission

The automatic transmission facilitates and simplifies the handling of the vehicle. The individual gears are shifted automatically dependent upon selector lever position, vehicle speed and accelerator position.

Hint

When parking the vehicle or if working on the vehicle with the engine running, depress parking brake pedal and move selector lever to position "P".

Starting

Shift selector lever to the desired driving position only when the engine is idling and the service brake is applied. Do not release the brake before moving off. The vehicle may otherwise start creeping when the selector lever is in a driving position.

Accelerator position

Partial throttle = early upshifting
= normal acceleration

Full throttle = retarded upshifting
= maximum acceleration

Depressing the accelerator beyond full throttle to kickdown position means downshifting to the next lower gear and thus maximum acceleration. If you ease up on the accelerator after having attained the desired speed, the transmission will shift up again.

Gearshifting is controlled by the vehicle speed.

Selector lever positions

The automatic gear shifting process can be adapted to specific operating conditions by means of the selector lever.

"P" Parking lock. The parking lock is an additional safeguard when parking the vehicle. Engage only when the car is stationary.

"R" Reverse gear. Shift reverse gear only with the vehicle at halt.

"N" Neutral. No power is transmitted from the engine to the rear axle. When the brakes are released, the vehicle can be moved freely (pushed, towed or tow-started). Do not engage **"N"** when driving except when the vehicle is in danger of skidding (e.g. on icy roads). See page 49.

"D" Drive. All gears are available. 1st gear can be engaged only by means of kickdown. Position **"D"** affords optimum driving characteristics under all normal operating conditions.

"S" Slope. Shifting up to 3rd gear only. 1st gear can be engaged only by means of kickdown. Suitable for moderate ascents and descents. As the transmission is shifted up to 3rd gear only, this position permits the utilization of the engine braking effect.

"L" Low. Upshifting to 2nd gear only. The vehicle starts out in 1st gear. For driving on steep mountain passes, for trailer operation in mountainous regions, under severe operating conditions and as braking position on extremely steep declines. If the selector lever is briefly shifted to position **"S"** and then returned to position **"L"**, 2nd gear is shifted sooner at higher speed.

Do not exceed top speeds corresponding to the individual selector lever positions. Refer to speedometer markings.

Starting and Shifting Gears

Maneuvering

To maneuver in restricted area, e.g. when pulling into a parking space, control the car speed by gradually releasing the service brake. Accelerate gently and do not pump the accelerator. To rock a car out of soft ground (mud or snow), alternately shift one forward gear range and the reverse gear at partial throttle.

Trailer operation

Do not allow the engine speed to drop too low at uphill gradients to prevent the engine from laboring at low RPMs. Depending on the degree of the incline, shift selector

lever to positions "S" or "L" early enough to maintain engine RPMs within best torque range.

Stopping

For brief halts, e.g. at traffic lights, leave the selector lever in a driving position and control vehicle with the service brake.

For longer stops with the engine idling, shift selector lever to position "N".

When stopping the car on a slope, do not hold it by means of the accelerator but use the brake. This avoids unnecessary heat-up of the transmission.

Safe Driving

Always drive according to the rule "Safety first". The comfortable ride of the vehicle may easily tempt you to underestimate the speed you are actually driving at. For this reason you should get used to keeping an eye on the speedometer needle because high speeds demand long stopping distances.

Do not attempt to move or roll the vehicle with the engine not in operation, as engine-driven accessories such as the power steering system or power brakes are not "powered", therefore, requiring substantially more effort for their operation even though they always remain mechanically operative.

Do not allow your tires to wear down too far. With less than appr. $\frac{1}{8}$ in. (3 mm) of tread, the antiskid properties on a wet road fall off sharply.

Depending upon the weather and/or road pavement, the grip of the tires varies widely.

The retention of the specified tire pressure is essential. This applies

particularly if the tires are subjected to high loads (e. g. high speeds, heavy loads, high ambient temperatures).

Aquaplaning:

Depending on the depth of the water layer on the road, aquaplaning may occur even with tires still showing the full tread depth, and even at low speeds. Avoid track grooves in the road and apply brakes cautiously in the rain.

Tire friction:

Dry road = 100 %

Wet road = from approx. 50 % to approx. 80 % (be particularly cautious on wet and dirty roads)

Icy road = approx. 15 %

A given speed at which a vehicle driven on dry roads can still be fully controlled must be reduced when the same vehicle is to be driven safely on a wet or icy road.

You should pay particular attention to the condition of the road as soon as the prevailing tempera-

tures fall close to the freezing point. If ice has formed on the road (e. g. due to fog), a thin film of water is then quickly produced on the ice which substantially reduces the grip of the tires. Under such weather conditions, drive, steer and brake particularly carefully.

We recommend M + S radial-ply tires for the cold season. On ice or packed snow, they can reduce your stopping distance as compared with summer tires. Stopping distance, however, is nevertheless considerably greater than when the road is wet or dry.

When driving down long and steep declines, relieve the brakes by engaging a lower speed (selector lever position "S" or "L" in the case of automatic transmissions). This prevents overheating of the brakes and reduces brake pad wear.

After hard braking it is advisable not to switch off the engine right away but to drive on for some

time so the air stream will cool down the brakes faster.

When driving in heavy rain for some time without applying the brakes, the first braking action may be somewhat retarded and increased pedal pressure may be necessary. For this reason, stay further away from vehicle in front.

The condition of the parking brake will be checked during every maintenance service. Furthermore it is recommended to exert once or twice between the regular maintenance services, a maximum pressure of 22 lbs. (10 kp) on the parking brake pedal for 10 seconds while travelling at a speed around 30 mph (50 km/h) on dry road. Pull release knob during this process! Repeat procedure once or twice. Exercise care, the stoplights do not work.

Have all inspections of and work on the brake system carried out by a MERCEDES-BENZ service station.

Safe Driving

If the parking brake is released and the brake warning light in the instrument cluster comes on, the brake fluid level in the reservoir is too low.

A leak or brake pad wear may cause a shortage of brake fluid in the reservoir.

Have brake system checked in a MERCEDES-BENZ service station as soon as possible.

Install only brake pads recommended by us. If other than recommended brake pads are installed, the braking properties of the vehicle can be affected to an extent that the safety is substantially impaired.

Brake Pad Wear Indicator

The brake pad wear indicator in the instrument cluster comes on when the key in the steering lock is turned to driving position "2" and it must go out when the engine is running. If the indicator lights up during braking or driving, this shows that the front wheel brake pads are worn down.

Have brake system checked in a MERCEDES-BENZ service station as soon as possible.

Brake Fluid

During the course of the operation of the vehicle, the boiling point of the brake fluid is continuously being reduced through the absorption of moisture from the atmosphere. Under extremely hard operating conditions, this moisture content can lead to the formation of vapor in the system thus reducing the system's efficiency. The brake fluid must therefore be replaced annually, preferably in the spring. It is recommended to use only brake fluid approved by MERCEDES-BENZ.

Your MERCEDES-BENZ dealer will provide you with additional information.

Charge Indicator Light

Should the charge indicator light fail to come on prior to starting when the ignition key is in position "2" or should it fail to go out after starting or during operation, this indicates a fault which must be repaired at a MERCEDES-BENZ service station as soon as possible.

Oil Pressure Gauge

The oil pressure may drop at idle speed to 7.1 psi (0.5 kp/sq.cm) if the engine is at operating temperature. This will not jeopardize its operational reliability. Pressure must, however, rise immediately upon acceleration.

The oil pressure gauge does not provide any information concerning the oil level in the engine.

Coolant Temperature Gauge

Due to the pressurized cooling system, the coolant only starts boiling at a temperature of approx. 257° F (125° C) with an antifreeze-blended coolant fill protecting down to -22° F (-30° C) (see also "Fuels, Coolants, Lubricants, etc.").

During severe operating conditions and stop-and-go city traffic the coolant temperature must rise to red marking only.

Safe Driving

Emission Control

Certain systems of the engine and/or adjustments serve to keep the toxic components of the exhaust gases within permissible limits required by law. (Nevertheless, we urgently advise you not to let the engine run in a closed garage.) These systems, of course, will function properly only when maintained strictly according to factory specifications. Any adjustments on the engine should, therefore, be carried out only by qualified MERCEDES-BENZ technicians. The adjustments of the engine should not be altered in any way. Moreover, the specified service and maintenance jobs must be carried out regularly according to MERCEDES-BENZ servicing requirements. For details refer to Emission Control and Maintenance Manual.

Driving Economically

Fuel Consumption

Fuel consumption depends to a great extent on driving habits and operating conditions.

For economical driving you should

- avoid frequent and quick acceleration
- avoid frequent slowdowns
- avoid high speeds

Recommended shift points for manual transmission

To obtain good results regarding fuel economy, the following shift points are recommended:

Shift

from 1st to 2nd at 13 mph (21 km/h)
from 2nd to 3rd at 22 mph (35 km/h)
from 3rd to 4th at 32 mph (52 km/h)

Driving in low temperature weather, in stop-and-go city traffic and on short hops, and in hilly country as well increases fuel consumption.

Engine Oil Consumption

Engine oil consumption can only be determined after a certain mileage has been covered. During the break-in period, higher oil consumption may be noticed and is normal. Frequent high engine speed operation will also cause increased oil consumption.

The First 1,000 Miles (1,500 km)

The more cautiously you treat your engine during the break-in period, the more satisfied you will be with its performance later on. Therefore, drive your vehicle during the first 1,000 miles (1,500 km) at moderate vehicle and engine speeds.

During this period, avoid heavy loads (full throttle driving) and high RPMs (no more than $\frac{2}{3}$ of maximum permissible speed in each gear) and do not force the engine to labor at low engine speed.

Shift down in good time!

On vehicles with automatic transmission, avoid accelerating by kick-down. It is not recommended to brake vehicle by means of manually shifting to a lower gear. We recommend to select positions "S" or "L" only at moderate speeds (for hill driving).

After 1,000 miles (1,500 km), speeds may gradually be increased to the permissible maximum.

Special Operating Conditions

Winter Driving

Have your car winterized in a MERCEDES-BENZ service station before the onset of winter.

- Engine oil change: If no "all-year round" engine oil is used, fill with recommended winter oil. For viscosity and capacity, refer to "Fuels, Coolants, Lubricants, etc. and last page".
- For diesel fuels, refer to page 85 and last page.
- Antifreeze in the coolant: Check antifreeze protection periodically. For capacity refer to "Fuels, Coolants, Lubricants, etc.".
- Additive in the windshield washer system: Add windshield washer solvent to the water in the windshield washer system.
- Test battery: Battery capacity drops with decreasing ambient temperature. A well charged battery ensures that the engine can always be started, even at low ambient temperatures.
- Tires: For the cold season we recommend mounting M + S radial-ply tires on all wheels. Permissible top speed for M + S radial-ply tires is 100 miles/h (160 km/h).

Hints for Driving

The most important rule for slippery or icy roads is to drive sensibly and to avoid abrupt acceleration, braking and steering action. Do not use the cruise control system under such conditions.

When the vehicle is in danger of skidding, declutch or — in case of an automatic transmission — move selector lever to position “N”. Try to keep the vehicle under control by means of corrective steering action.

Provided the traffic conditions will allow, only brake in a way that the wheels are locked for no more than fractions of a second as otherwise the steerability of the vehicle is lost.

Thawing salts and water can adversely affect the braking efficiency. Increased pressure on the pedal may be required to achieve the usual braking effect.

We therefore recommend you to actuate the brakes repeatedly in order to test their efficiency after driving on salt treated roads for some time. In doing this it must, of course, be made sure that no danger is created for other road users.

If the vehicle is parked after being driven on salt treated roads, the braking efficiency should be tested as soon as possible after driving is resumed while adhering to the safety requirements. Should the braking efficiency have deteriorated considerably it can be improved again by braking several times.

High Altitude Correction Device

The engine is equipped with an automatic high altitude correction device.

Tire Chains

Tire chains can only be used on the driving wheels. Use only chains tested and recommended by us. Any MERCEDES-BENZ service station will readily advise you. Retighten newly mounted tire chains after a few miles of driving. Do not exceed permissible maximum speed of 30 mph (50 km/h). On clear roads remove the chains as soon as practicable. Adhere to the manufacturer's mounting instructions.

Traveling Abroad

Abroad, too, there is a widely-spread MERCEDES-BENZ service network at your disposal. If you travel into areas which are not listed in the index of your service station booklet, you should request pertinent information from your dealer.

Vehicle Care



MERCEDES-BENZ Maintenance System

Like any other mechanical equipment, the vehicle requires care and maintenance.

A maintenance booklet is delivered with your car listing all the maintenance jobs that must be carried out after the following mileages:

- Once after 300 to 600 miles (500 — 1,000 km).
- Once after 3,000 miles (5,000 km).
- After 12,500 miles (20,000 km) and thereafter every 12,500 miles (20,000 km), but at least once a year.

We would also like to draw your attention to the hints contained in the maintenance booklet covering necessary lubrication services every 3,000 miles (5,000 km), lubrication and brake inspections every 6,000 miles (10,000 km), additional maintenance jobs every 37,500 miles (60,000 km) and MB individual maintenance as required.

Renew brake fluid once a year, preferably in spring. Use only recommended brake fluids.

The vehicle must receive the prescribed maintenance and/or lubrication work at the specified intervals as listed in the maintenance booklet. Verification of performance of such maintenance/lubrication work should be recorded in the spaces provided in the maintenance booklet.

The maintenance jobs are described in detail in a manual which you can order from your MERCEDES-BENZ service station.

A small sticker attached to the door post of the driver's door by the service station personnel is to remind you when the next maintenance service, lubrication and brake inspection or lubrication service is due.



Maintenance service



Lubrication and
brake inspection



Lubrication service

Severe Operating Conditions

In the case of severe operating conditions or heavy use mainly in city traffic or over short distances, frequent mountain driving, poor roads, dusty and muddy conditions, trailer operation, hard and sporty driving, etc., it may be necessary to inspect e. g.

- the front axle brake linings
 - the tires
- at shorter intervals.

Any MERCEDES-BENZ service station will be pleased to give you expert and individual advice.

Engine Oil Change and Filter Change

To be carried out every 3,000 miles (5,000 km), but at least twice a year (in spring and fall).

Under severe operating conditions or if diesel fuels with high sulphur content (in excess of 0.5 % by weight) are used, the oil should be changed every 1,500 miles (2,500 km). It is not mandatory to change the filter at this oil change.

For regular oil level checks, refer to "Checking Fuels, Coolants, Lubricants, etc.".

Automatic Transmission — Fluid and Filter Change

To be carried out every 37,500 miles (60,000 km) according to the maintenance booklet.

Under severe operating conditions, have the automatic transmission fluid changed every 12,500 miles (20,000 km) without filter change.

All MERCEDES-BENZ service stations store the MERCEDES-BENZ original spare parts required for maintenance and repair work. In addition, depots are provided all over the globe intended to ensure the rapid supply of MERCEDES-BENZ original spare parts.

More than 200,000 different spare parts, even for rather old vehicle models, are furthermore stocked in the central plant warehouses.

We warrant maximum operational efficiency and reliability as well as optimum retention of the vehicle value when MERCEDES-BENZ original spare parts are installed, as they are subjected to most severe quality inspections. Each part has been specifically developed, manufactured or selected for and adapted to MERCEDES-BENZ vehicles.

For this reason, only MERCEDES-BENZ original spare parts should be installed.

Cleaning and Care of the Vehicle

In operation, your vehicle is subjected to a great amount of varying external influences which, if gone unchecked, can attack the paint-work as well as the underbody and cause lasting damage.

Such damage is caused not only extreme and varying climatic conditions, but also by air pollution, road salt, tar, gravel and stone chipping. Grease and oil, fuel, coolant, brake fluid, bird droppings, tree resins, etc. should be immediately removed to avoid paint damage. Frequent washing, however, reduces and/or eliminates the aggressivity and potency of the above adverse influences.

Special car-care measures may be necessary to deal with unfavorable conditions; for example, near the coast, in industrial areas (smoke, exhaust emissions), or during winter operation.

You should check over your vehicle from time to time for stone chipping or other damage. Any damage should be repaired as soon as possible.

In doing so, do not neglect the underside of the car. A prerequisite for a thorough check is a washing of the underbody followed by a rustproofing treatment.

Your vehicle has been treated at the factory with a wax-base rest-proofing in the body cavities.

After every engine cleaning you should have the engine compartment rustproofed. Before rustproofing, all control linkage bushings have to be lubricated with hydraulic oil (check with your local MERCEDES-BENZ dealership for recommended brands).

We have selected car-care products and compiled recommendations which are specially matched to our vehicles and which always reflect the newest in technological standing. You can obtain MB car-care products at every MERCEDES-BENZ service center.

Scratches, corrosive deposits, corrosion or damage due to negligent or incorrect care cannot always be removed with the car-care products recommended here. In such cases it is best to seek aid at your MERCEDES-BENZ service center.

The following topics deal with the cleaning and care of your vehicle and give important "how-to" information as well as references to recommended MB car-care products.

Car Wash

Before washing your vehicle, remove insect residues. The car should not be washed in the sun.

Thoroughly spray the car with a diffused jet of water. Direct only a very weak spray towards the ventilation intake. Use plenty of water and rinse the sponge and chamois frequently. Rinse with clear water and thoroughly wipe dry with a chamois.

If the vehicle has been run through an automatic car wash — in particular one of the older installations — rewipe the recessed sections provided in the tail lights (for improved prevention of soiling) if necessary. No solvents (fuels, thinners, etc.) must be used.

In the winter, thoroughly remove all traces of road salt as soon as possible.

When washing the car underbody, do not forget to clean the inner sides of the wheels.

Tar Stains

Quickly remove tar stains before they dry and become more difficult to remove.

Window Cleaning

Use a window cleaning solution on very dirty or oil-stained windows. Clean windshield wiper blades with a clean cloth and washing solution. Replace blades once or twice a year.

Plastic Parts, Rubber Parts and MB-Tex Upholstery Covers

Do not use oil or wax on these parts.

Seat Belts

The webbing must not be treated with chemical cleaning agents. Use only clear, lukewarm water and

soap. Do not dry the webbing at temperatures above 176° F (80° C) or in direct sunlight. Never bleach or re-dye the webbing.

Steering Wheel and Gear Shift Lever

Use a gentle dish-washing detergent or mild detergent for delicate fabrics as a washing solution. Wipe with a cloth moistened in lukewarm solution. Do not use scouring agents.

Upholstery

Leather: Wipe leather upholstery with a damp cloth and dry thoroughly. Exercise particular care when cleaning perforated leather as its underside should not become wet.

Cleaning and Care of the Vehicle

Velours: Pressure marks resulting from dampness and heat may appear to be stains. Such marks can be removed by wiping with a moistened brush, ironing with a wet cloth or by treating with a dry shampoo. Do not sit on damp upholstery. Quick drying is achieved by applying hot air — for example, by using a hair dryer. If in doubt, please consult your MERCEDES-BENZ service station.

Paintwork

Do not apply wax if your car is parked in the sun or if the hood is still hot. For maximum protection, the paintwork should be waxed approximately once every three months. Use the appropriate MERCEDES-BENZ Touch-Up Stick for quick and provisional repairs of minor paint damage.

Ornamental Moldings (Chrome-Plated, Aluminium)

For regular cleaning and care of very dirty chrome-plated parts, use a chrome cleaner.

Practical Hints

Practical Hints

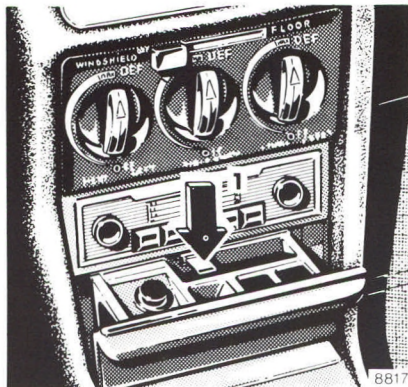

Ash trays

To remove front ash tray:
Pull ash tray out as far as possible.
Push down the spring (1) in the center and remove ash tray.

To install ash tray:
Position ash tray squarely and push in.

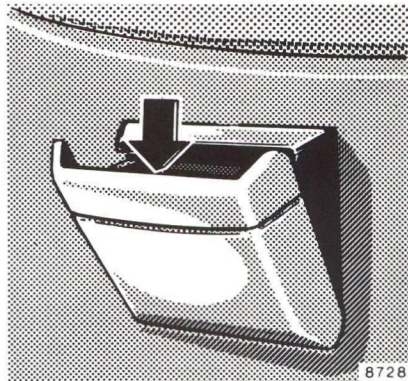

To remove rear ash tray:

Push the ash tray down while opening and remove.

To install ash tray:

Position ash tray squarely and push in.

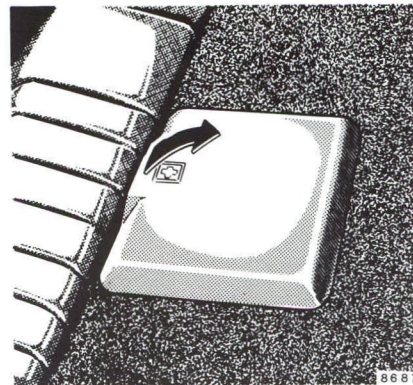

First Aid Kit

The first aid kit is stowed in a cavity in the hat shelf at the rear.

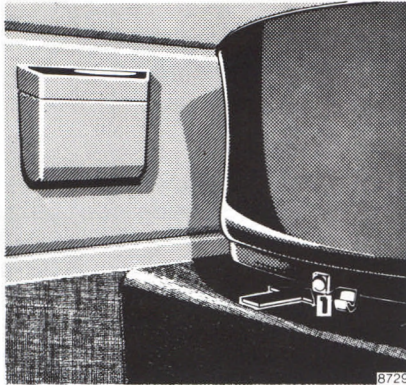

Rear Seat Cushion

Removal: Depress buttons 1 (left and right) and at the same time slightly lift up rear seat cushion at the front end. Then pull the cushion forward. (Center arm rest of rear seat cushion must be folded up.)

Installation: Push rear edge of rear seat cushion under the backrest to the stop, press down front edge onto the support and allow to engage.

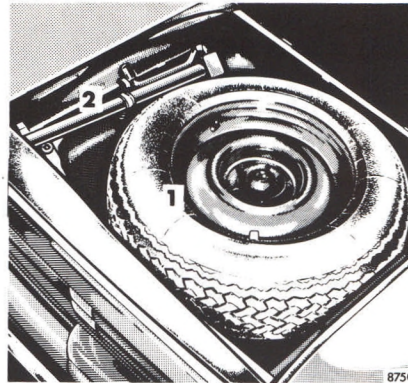

Spare Wheel, Jack, Vehicle Tool Kit

Spare wheel (1), jack (2) and the tool kit are stowed in a trough below the trunk floor.

Fold back trunk floor mat and remove cover plate.

Note:

The jack is designed exclusively for jacking up the vehicle at the jack tubes provided on either side of the vehicle. Jack stands must be used when working under the vehicle.

Luggage or Ski Racks

The only type of rack to be mounted on the roof we recommend is the drip rail mounted type which has no other supports (suction cups or legs) to support the rack on the roof. Such supports may lead to marring of the paint or even denting of the roof if excessive weight is placed on the rack. Your MERCEDES-BENZ dealer can give further advice.

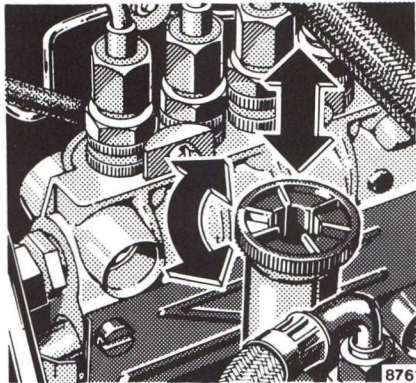

Bleeding the Fuel System

A completely bled fuel system is imperative for perfect engine operation. During operation, the system is continuously bled via the overflow line.

The entire system must be bled when the car has been driven until the fuel tank was completely emptied.

After refueling, start the engine, engaging the starter for about 20 seconds until all the trapped air has been evacuated.

With a poorly charged battery the system must be bled manually.

Operate the primer pump until the injection pump overflow valve opens (rattling noise audible).

Disengage primer pump handle prior to operating it (turn counterclockwise). Retighten after use.

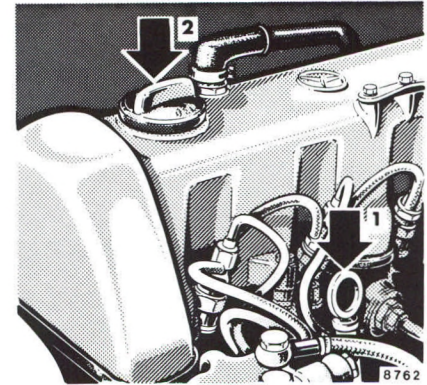

Engine Oil Level Check

Check engine oil level at regular intervals, e.g. after refueling, with the engine at operating temperature and shut off.

- 1 Dipstick
- 2 Oil filler hole

The vehicle should be parked on level ground and the oil level must be somewhere between the lower and the upper mark on dipstick (1); do not replenish in excess of the upper mark.

For viscosity and capacity, see "Fuels, Coolants, Lubricants, etc., and last page".

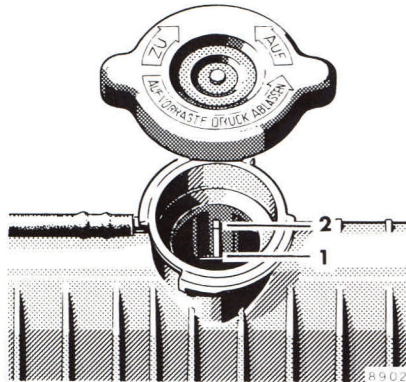

Replenishing Coolant

The coolant level must reach:

- to marking 1 if the coolant is cold,
- to marking 2 if the coolant is hot.

Do not remove radiator cap if engine temperature is above 194° F (90° C). Allow engine to cool down before removing cap. The radiator contains hot water and is under pressure.

First turn cap to first notch to relieve excess pressure using a rag. If opened immediately, hot scalding fluid and steam will be blown out under pressure.

Add cold water only if engines is running. Both hot and cold engines can be readily filled up with hot water (see also “fuels, coolants, lubricants, etc.”, page 86).

If a small amount of coolant has to be added (due to evaporation of water), plain water can be added.

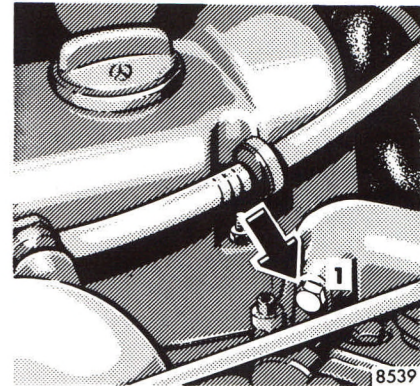

If a larger quantity of coolant has to be added, a 50/50 mixture of water and antifreeze should be used.

The drain plugs are on the RH side of the engine and LH bottom mount of the radiator.

Important

Bleed screw (1) must be removed when filling empty radiator. Turn in screw as soon as coolant emerges.

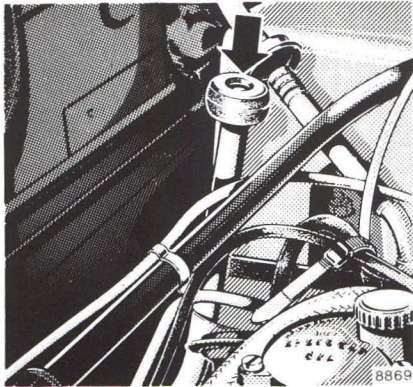

Fluid Level — Automatic Transmission

At regular intervals, check the fluid level of the automatic transmission together with the engine oil level prior to every long trip, at the latest, however, after every 3,000 miles (5,000 km).

Check transmission fluid level with the engine idling, parking brake engaged and selector lever in position "P". The vehicle must be parked on level ground. Prior to the check, allow engine to idle for approx. 1 to 2 minutes.

Exercise utmost cleanliness! To wipe the dipstick, use a clean and lintless cloth (preferably leather). To fill the transmission with fluid, only pour it through a fine-mesh filter into the dipstick opening. Even the slightest impurity may cause operational troubles.

The oil level in the transmission is dependent upon the oil temperature. The maximum and minimum

oil level marks on the dipstick are applicable references only if the transmission fluid has reached its normal operating temperature of 176° F (80° C).

If, however, the transmission fluid cools down to 68 — 86° F (20 — 30° C), which is the normal shop temperature range, then the maximum oil level will be approximately 1.2 in. (30 mm) below the minimum mark on the dipstick.

We stress this point because an oil change is normally performed when the transmission oil has cooled down to shop temperature.

The fluid level must not exceed the dipstick maximum mark with the fluid at operating temperature. Drain or siphon off excess fluid, if required.

Wheels, Tires

In case of replacement we recommend you use tires of identical design, version and brand.

See any MERCEDES-BENZ service station for information on tested and recommended wheels and tires for summer and winter operation. They will also offer more advice concerning tire service and purchase.

Mount newly acquired single tires on the front axle. It is advisable to break in new tires over a mileage of approximately 60 miles (100 km) at moderate speeds.

To prevent damage to the valves, vehicles equipped with steel rims must only be driven with the hub caps installed.

For tire specifications, refer to "Technical Data".

Rotating wheels:

The wheels can be rotated according to the degree of tire wear while retaining the same sense of rotation. Rotating, however, should be carried out before the characteristic tire wear pattern (shoulder wear on front wheels and tread center wear on rear wheels) becomes visible at a mileage of 3,000 — 6,000 miles (5,000 — 10,000 km) as otherwise the driving properties deteriorate.

Slowly leaking air (e. g. due to a nail in the tire) may cause damage to the tire such as tread separation. Regular tire pressure checks at intervals of no more than 14 days are therefore essential. For the tire pressure checks, keep in mind that hot tires show higher pressure than cold tires. See tire pressure chart on last page.

Should the tire pressure decrease constantly, check whether foreign objects have penetrated the tire or if rim or valve allow the air to leak.

Caution: Use longer wheel bolts for light alloy rims than those required for steel rims (see illustration on page 64).

Thoroughly clean the inner side of the wheels any time you rotate the wheels or wash vehicle underside.

Dented, bent or corroded rims cause tire pressure loss and damage to the tire beads. For this reason, check rims for damage at regular intervals. Derust steel rims and spot paint, if required.

Check rim flanges of light alloy rims for wear prior to mounting a tire. If necessary, remove burrs.

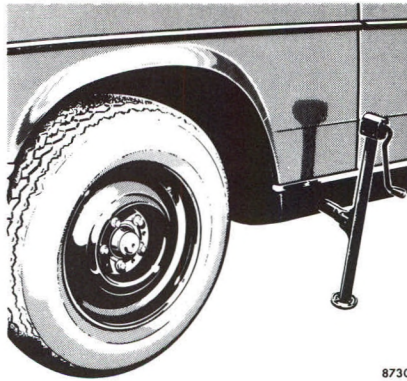
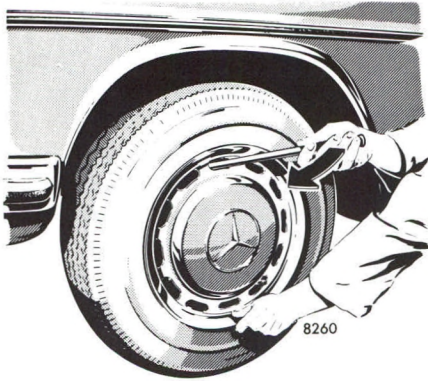

Observe wheel bolts!

- 1 For light alloy rims only
- 2 For steel rims only

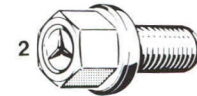
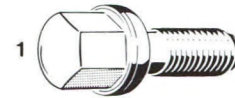

9103

Changing Wheels

1. Depress parking brake pedal.
2. With manual transmission, shift gear shift lever to 1st or reverse gears respectively, with automatic transmission, move selector lever to position "P".
3. Safeguard vehicle against rolling off by using chocks or similar. Place chocks under both opposite wheels (on downhill side), on a level road on both sides of the opposite front wheel when changing a rear wheel.

4. Insert the combination wrench in one of the trim ring slots and pry off the hub cap.
5. Using the combination wrench, loosen but do not yet remove the wheel bolts.
6. Clean jack supporting tube, if necessary. (Jack tubes are behind the front wheel housings and in front of the rear wheel housings.)
7. Insert jack arm into the tube hole up to the stop. Position the jack so that it will always be

vertical as seen from the side, even on inclines. Jack up the vehicle until the wheel is clear of the ground.

8. Then back out the wheel bolts. Protect bolt threads from dirt and sand. Remove the wheel.
9. Adjust the jack to allow the wheel to be slipped on without being lifted.
10. Slip on wheel (valve down) and press onto the hub plate. Screw in wheel bolts but use only such bolts that suit the particular rim.

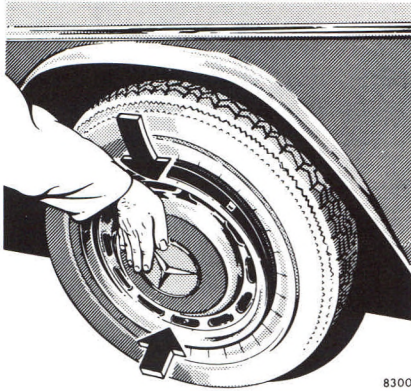

11. Lower car and remove jack. Tighten the five bolts evenly by going around the wheel and tightening every other bolt until all the bolts are tight. Observe a tightening torque of 72 ft. lbs. (10 mkp).
12. To install the hub cap, slip the tire valve through one of the slots appr. in the middle between two hub cap mounting clips and press the hub cap

against the wheel flange at this point. Then push the two opposite clips against the rim and seat the hub cap by firmly striking it towards the valve with the flat of the hand.

13. Correct tire pressure.

Tire Pressure

A table (see fuel filler flap or last page) lists the tire inflation pres-

ures specified for summer and winter tires as well as for the varying operating conditions.

Tire temperature and pressure increase with the vehicle speed. Tire pressure should therefore only be corrected on cold tires. Correct tire pressure in hot tires only if pressure has dropped below the data listed in the table and the respective operating conditions are taken into consideration.

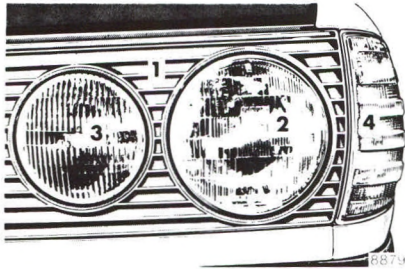

Replacing Bulbs

To remove, push the bulb in and turn to the left, then lift the bulb out.

To install, grip the bulb with a paper tissue or similar cloth, align the pins on the base of the bulb with the grooves in the bulb socket, push in lightly and turn to the right until the stop is felt.

Install only bulbs of prescribed wattage. Refer to "Technical Data and last page".

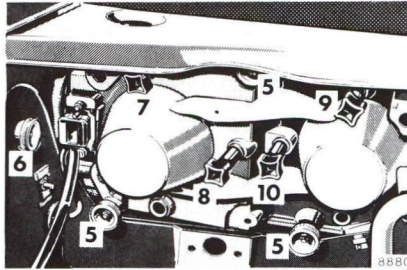

Headlight Aiming

Correct headlight aiming is of paramount importance to the roadworthiness of the car. Check and readjust headlights at regular intervals and invariably when a lamp has been replaced.

Front Lights

(Sealed Beam Version — USA Specifications, Fog Light)

- 1 Cover. Remove cover (1) after backing out knurled plastic nuts located behind headlights.
- 2 Sealed-beam unit for high and low beam

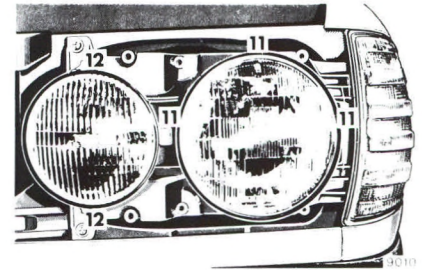

- 3 Fog light
- 4 Turn signal, clearance (standing) and side marker light
- 5 Securing nuts for cover
- 6 Securing nuts for turn signal, clearance (standing) and side marker light
- 7 Vertical aiming screw, sealed-beam unit
- 8 Horizontal aiming screw, sealed-beam unit
- 9 Vertical aiming screw, fog light
- 10 Horizontal aiming screw, fog light

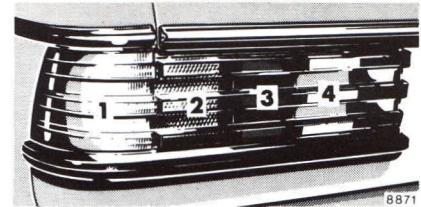
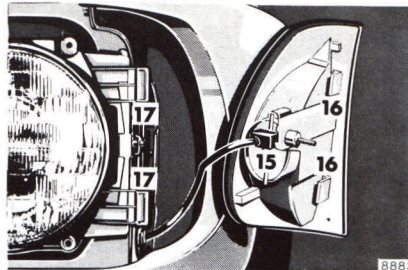
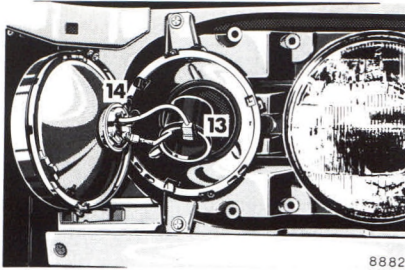

- 11 Securing screws for sealed-beam unit retaining ring. Loosen securing screws, remove retaining ring and unit. Pull off connector.
- 12 Securing screws for fog light retaining ring. Loosen securing screws and take out light body. Pull off plug (13). Disengage retaining spring and remove bulb (14).

- 15 Bulb for turn signal, clearance (standing) and side marker light. Loosen fastener (6). Push light body forward and detach. Hold lamp holder by the wide lug and pull out. Depress bulb, turn to the left and take out. When installing the bulb holder, the lugs must engage the light body recesses. When installing the light body, never fail to engage the locating webs (16) between the retaining springs (17).

Tail Light Assembly

Remove both knurled nuts in the trunk and pull off lens assembly. To replace the bulbs, depress, turn left and pull out.

- 1 Turn signal light side marker light
- 2 Standing light/tail light
- 3 Stop light
- 4 Back up light

Electrical System

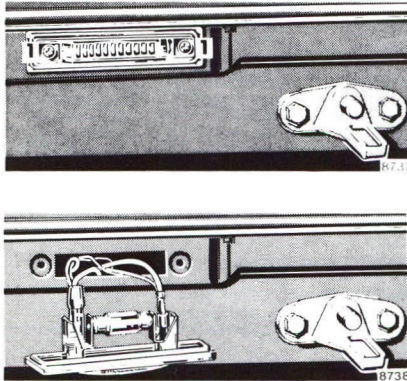

License Plate Lights

Open trunk lid. Loosen both the securing screws (1) and take out light.

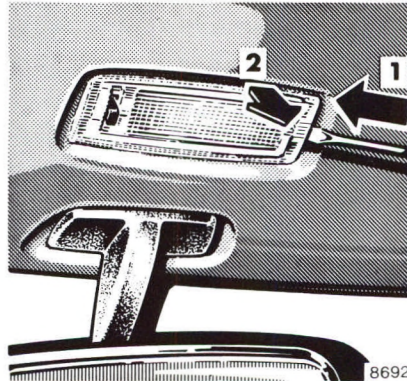

Courtesy Lights

To replace the bulb, press courtesy light slightly towards the left (1), lift off at right-hand side (2) and pull out to the right.

The same applies when removing the rear courtesy light.

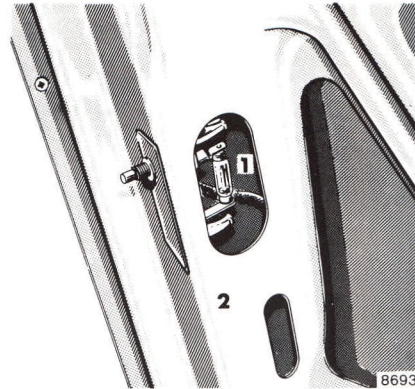

Trunk Light

The bulb (1) is easily accessible when the trunk lid (2) is opened.

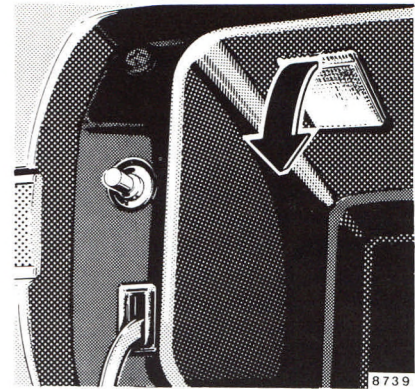

Glove Compartment Light

To replace the bulb, pull out light.

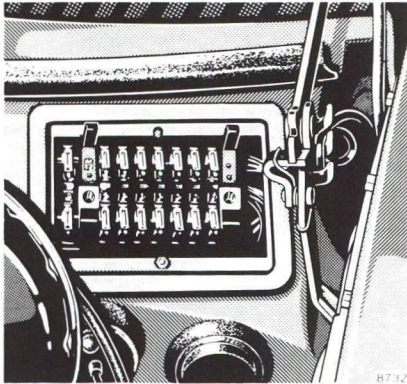

Fuses

The fuse box is located in the engine compartment.

A summary of the protected equipment is printed in the fuse box cover.

Fuse arrangement in the box — starting at engine side, proceeding from inside to outside —
upper row: odd numbers
1, 3, 5 etc. up to 13;
lower row: even numbers
2, 4, 6 etc. up to 14.

Fuses must be replaced, not repaired or bridged.

Spare fuses are stored in the fuse box (observe amperage and color code).

Determine the cause of a short prior to replacing a burned-out fuse.

After replacing a fuse, screw on the fuse box cover firmly.

Battery

Approximately every four weeks, and more frequently in summer and in tropical zones, check the electrolyte level in the battery cells from outside.

The electrolyte level must be somewhere between the lower and the upper marking.

Replenish only with distilled water and do not use metal funnels. Do not overfill battery.

Lubricate battery terminals with acidproof grease. Keep battery clean and dry.

Tow-start vehicle only with the battery connected. Only charge battery with rapid charging equipment if it has been disconnected from the vehicle's electrical circuit.

Note:

Battery terminals must not be loosened or detached while the engine is running as otherwise the three-phase alternator will be destroyed.

Emergency Operation of Sliding Roof

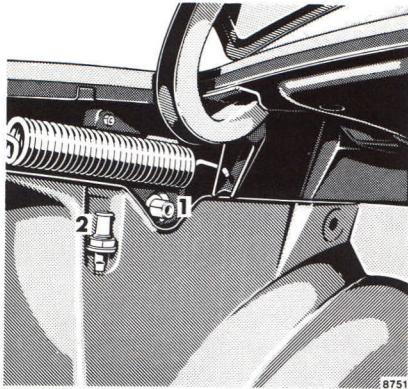

If the electric drive fails, the sliding roof can also be moved by hand. For this purpose a manual drive (1) has been provided on the drive motor (LH side of trunk).

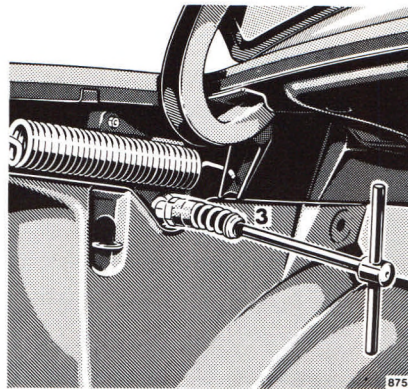

ual drive can be rotated by means of adapter (2) and spark plug wrench (3) to move the sliding roof in the desired direction. To close the sliding roof, turn clockwise.

Unlocking of the Filler Flap

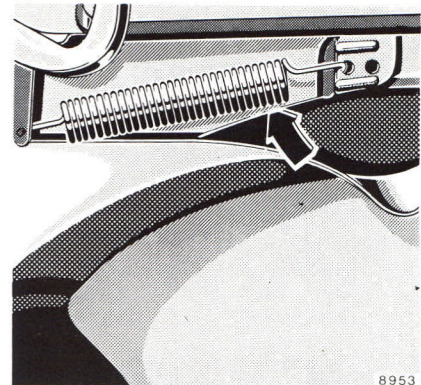

If the filler flap cannot be opened when the master lock system is unlocked, withdraw the link of the vacuum element (on RH side in trunk).

Emergency-starting and Towing the Vehicle

Towing eyes are situated underneath the front and rear end on the RH side. Use a solid towing link such as a towbar.

Tow-start vehicle only with the battery connected.

Caution: Remember, however, that until the engine is running, the power steering and power brakes do not offer assistance and considerable additional effort is required to steer and stop the car.

Emergency Starting of an Engine (Tow-starting) in a Vehicle with Automatic Transmission

Turn idle speed adjusting knob counterclockwise to the stop. Shift

selector lever to "N" and turn key in steering lock to position "2".

Have vehicle towed. Having attained a speed of 18 mph (30 km/h) — cold transmission — or 30 mph (50 km/h) — warm transmission — keep on driving at this speed for approximately 2 minutes to ensure sufficient fluid pressure in the transmission.

To crank the engine, shift selector lever to "L" (300 D, 300 CD — "S"). Touch the accelerator only when the engine starts firing. As soon as the engine has started, immediately return selector lever to "N". Adjust idle speed. It is important to allow the engine to idle for at least 3 minutes before starting off

because the preglowing process starts when the key is in steering lock position "2" and is not immediately disrupted after the engine has been tow-started. During this time the preglowing process is cut out automatically.

If the engine has not fired after a few seconds, shift the selector lever from "L" to "N" to protect the transmission from damage.

For a new starting attempt, tow-start the vehicle for some time again with the selector lever in position "N" and repeat the starting procedure.

The same method can be used to start the engine in emergencies when rolling downhill.

Emergency-starting and Towing the Vehicle

Starting the Engine with Jumper Cable (35 mm² Minimum Cable Cross Section) and Auxiliary (Booster) Battery

Connect positive (+) terminal of auxiliary battery to positive terminal of car battery and negative (-) terminal of the auxiliary battery to the negative terminal of the car battery. If the battery of another vehicle is used, the engine of the other car should be run at high idle. After the engine has started, first disconnect the negative terminal and then the positive terminal.

If the engine is started with charging equipment, the battery must be connected.

Towing a Vehicle with Automatic Transmission

The vehicle may be towed with the driving wheels on the ground and the selector lever in position "N" for distances up to 75 miles (120 km) and at a speed not to exceed 30 mph (50 km/h).

To positively avoid a possibility of damage to the transmission, however, we recommend to disconnect the drive shaft at the rear axle drive flange on any towing beyond a short tow to a nearby garage.

Turning off Engine Manually

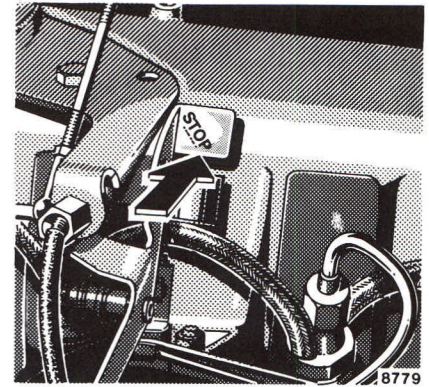

If the engine continues operating in steering lock position "0", open hood and press lever marked "STOP" towards engine until it stops.

Technical Data
Fuels Coolants
Lubricants etc.

Identification Plates Vehicle Data Cards

When ordering spare parts, please quote chassis and engine numbers.

With your MERCEDES-BENZ you receive two vehicle data cards listing all major vehicle data.

Data card No. 1 bears the key number and should on no account be left in the vehicle. Submit this card to your MERCEDES-BENZ service station to request a replacement key in case of loss.

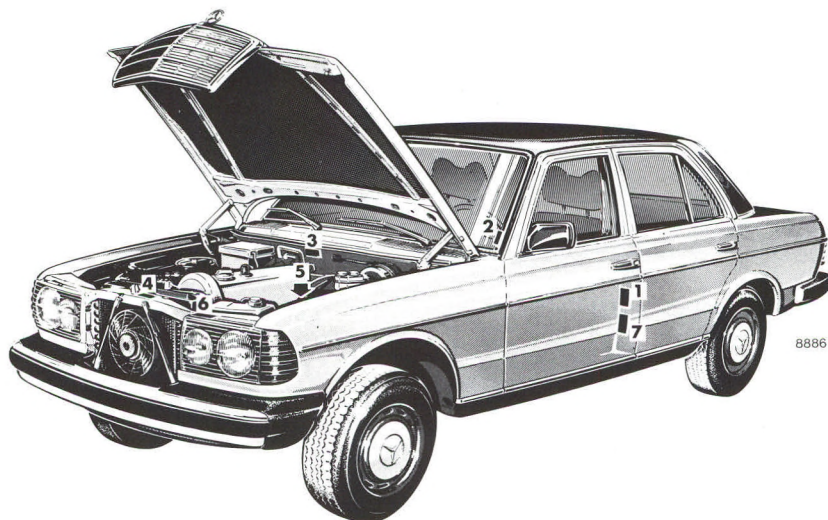

- 1 Certification Tag (left door pillar)
- 2 Identification Tag (left window post)
- 3 Chassis No.

- 4 Body No. and Paintwork No.
- 5 Engine No.
- 6 Emission Control Tag
- 7 Emission Control Tag Catalyst Information

The production data card bears no key data and is kept in the maintenance booklet. Presenting this card to the service station will facilitate the processing of the order.

Type 240 D (123 123)¹

Engine

Engine type 616
 Work cycle Diesel four stroke
 No. of cylinders 4
 Bore 3.58 ins. (90.9 mm)
 Stroke 3.64 ins. (92.4 mm)
 Total piston displacement .. 146.4 cu.ins.
 (2,399 cm³)
 Compression ratio 21
 Output acc. to SAE 62 net bhp/4,000 rpm

Valve clearance } Intake ... 0.004 in. (0.1 mm)
 (cold engine) } Exhaust .. 0.012 in. (0.3 mm)
 Injection order 1 - 3 - 4 - 2

V-belts:
 Water pump - fan - alter-
 nator 9.5 x 970 mm
 Power steering 12.5 x 1,150 mm
 Air conditioning 12.5 x 1,350 mm

Transmission

Design Manual four-speed
 transmission
 Optional extra. Automatic four-speed
 torque-converter
 transmission

Steering System

Design Power steering

Rims - Tires

Rims 5 1/2 J x 14 H 2
 Summer tires:
 Radial-ply tires 175 SR 14
 Winter tires:
 Radial-ply tires 175 SR 14 M + S

Electrical System

3-phase alternator. 14 V / 55 A
 Starter motor 12 V / 2.5 H.P.
 Battery 12 V / 88 Ah

The quoted data apply only to the standard vehicle. See a MERCEDES-BENZ service station for the corresponding data of all special bodies and special equipment.

Technical Data 240 D

Bulbs	12 V
High and low beams	Sealed beam
Fog lights	H 3
Turn signal, clearance and side marker lights, front	21/5 W (32/3 cp)
Stop lights	21 W (32 cp)
Turn signal lights, rear	21 W (32 cp)
Side marker lights, rear	4 W (2 cp)
Tail and standing lights	10 W (6 cp)
Backup lights	21 W (32 cp)
License plate lights	5 W festoon lamp
Interior lights	10 W festoon lamp
Trunk light	10 W festoon lamp
Glove compartment light	5 W festoon lamp

Main Dimensions

Overall vehicle length	190.9 ins. (4,848 mm)
Overall vehicle width	70.3 ins. (1,786 mm)
Overall height (unloaded)	56.6 ins. (1,438 mm)
Wheel base	110.0 ins. (2,795 mm)
Track, front	58.6 ins. (1,488 mm)
Track, rear	56.9 ins. (1,446 mm)

Weights See certification tag

Type 300 D (123 130)¹
 300 CD (123 150)¹

Engine

Engine type 617
 Work cycle Diesel four stroke
 No. of cylinders 5
 Bore 3.58 ins. (90.9 mm)
 Stroke 3.64 ins. (92.4 mm)
 Total piston displacement. 183.0 cu.ins.
 (2,998 cm³)
 Compression ratio 21
 Output acc. to SAE 77 net bhp/4,000 rpm
 Valve clearance } Intake 0.004 in. (0.1 mm)
 (cold engine) } Exhaust 0.012 in. (0.3 mm)
 Injection order 1 – 2 – 4 – 5 – 3

V-belts:

Water pump — fan — alter-
 nator. 9.5 x 980 mm
 Power steering 12.5 x 1,150 mm
 Air conditioning 12.5 x 1,350 mm

Transmission

Design Automatic four-speed
 torque-converter
 transmission

Steering System

Design Power steering

Rims — Tires

Rims 6 J x 14 H 2
 Summer tires:
 Radial-ply tires 195/70 HR 14
 195/70 SR 14
 Winter tires:
 Radial-ply tires 195/70 SR 14 M + S

Electrical System

3-phase alternator. 14 V / 55 A
 Starter motor 12 V / 2.5 H.P.
 Battery 12 V / 88 Ah

The quoted data apply only to the standard vehicle. See a MERCEDES-BENZ service station for the corresponding data of all special bodies and special equipment.

Technical Data 300 D, 300 CD

Bulbs	12 V
High and low beams	Sealed beam
Fog lights	H 3
Turn signal, clearance and side marker lights, front	21/5 W (32/3 cp)
Stop lights	21 W (32 cp)
Turn signal lights, rear	21 W (32 cp)
Side marker lights, rear	4 W (2 cp)
Tail and standing lights	10 W (6 cp)
Backup lights	21 W (32 cp)
License plate lights	5 W festoon lamp
Interior lights	10 W festoon lamp
Trunk light	10 W festoon lamp
Glove compartment light ...	5 W festoon lamp
Weights	See certification tag

Main Dimensions 300 D

Overall vehicle length	190.9 ins. (4,848 mm)
Overall vehicle width	70.3 ins. (1,786 mm)
Overall height (unloaded) ...	56.6 ins. (1,438 mm)
Wheel base.	110.0 ins. (2,795 mm)
Track, front	58.6 ins. (1,488 mm)
Track, rear	56.9 ins. (1,446 mm)

Main Dimensions 300 CD

Overall vehicle length	187.5 ins. (4,763 mm)
Overall vehicle width	70.3 ins. (1,786 mm)
Overall height (unloaded) ...	54.9 ins. (1,395 mm)
Wheel base.	106.7 ins. (2,710 mm)
Track, front	58.6 ins. (1,488 mm)
Track, rear	56.9 ins. (1,446 mm)

Vehicle components and their respective lubricants must match.

Therefore use only brands tested and recommended by us.

Enquire at your MERCEDES-BENZ service station.

	Type	Capacity
Total oil capacity in case of engine oil and filter change	240 D 300 D 300 CD	7/5.7 US/Imp. qts. (6.5 l)
Total oil capacity in case of engine oil change without filter replacement		5.2/4.4 US/Imp. qts. (5.0 l)

Fuels, coolants, lubricants, etc.

Recommended engine oil

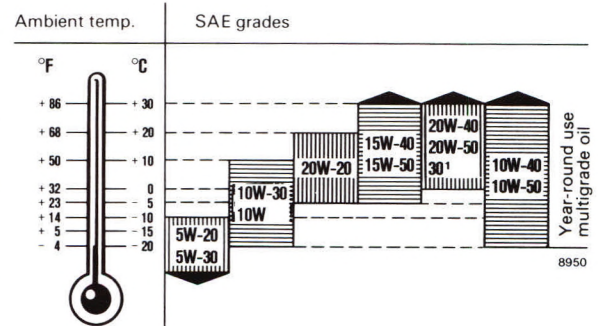

SAE 40 may be used if ambient temperatures constantly exceed +86° F (+ 30° C).

Fuels Coolants Lubricants etc. Capacities

	Type	Capacity	Fuels, coolants, lubricants, etc.
Manual transmission	240 D	3.4/2.8 US/Imp. pts. (1.6 l)	Engine oil SAE 10 W/20 W-20
Automatic transmission	240 D 300 D 300 CD	Initial fill: 6.4/5.4 US/Imp. qts. (6.1 l) Fluid change: 5/4.2 US/Imp. qts. (4.8 l)	Automatic transmission fluid (ATF)
Rear axle		2.1/1.8 US/Imp. pts. (1.0 l)	Hypoid gear oil SAE 90
Accelerator control linkage			Hydraulic fluid
Power steering		3/2.5 US/Imp. pts. (1.4 l)	Automatic transmission fluid (ATF)
Front wheel bearings		2.1 oz. each, approx. (60 g each, appr.)	Multipurpose or antifriction bearing grease
Grease fittings			Multipurpose or lubrication grease

Fuels Coolants Lubricants etc. Capacities

	Type	Capacity	Fuels, coolants, lubricants, etc.
Door locks	240 D 300 D 300 CD		Special grease
Battery terminals			Bosch special grease
Brake and (with mechanical transmission) clutch reservoir		1.1/0.9 US/Imp. pts. (0.5 l)	Brake fluid
Windshield washer system		approximately 5.3/4.4 US/Imp. qts. (5.0 l)	Water plus windshield detergent
Fuel tank including a reserve of		approximately 21.1/17.6 US/Imp. gal. (80 l) approximately 3.0/2.5 US/Imp. gal. (11.5 l)	Diesel fuels acc. to ASTM D 975, grades 1 and 2 as well as VV-F-800a grades 1 and 2
Cooling system	240 D	10.6/8.8 US/Imp. qts. (10 l)	Coolant
	300 D 300 CD	11.6/9.6 US/Imp. qts. (11 l)	

Engine Oils

Engine oils are specifically tested for their suitability in our engines. Therefore, use only engine oils recommended by us. Information on recommended brands is available at any MERCEDES-BENZ service station.

A new or reconditioned engine is filled with an initial operation oil in

the factory or in a MERCEDES-BENZ service station. This oil is specially developed for the specific operating conditions during the first 300 – 600 miles (500 – 1,000 km).

A recommended engine oil may be used for topping up if the oil level drops below the dipstick minimum mark prior to the first service 300 – 600 miles (500 – 1,000 km).

Brake Fluid

Brake fluid should be changed once a year, preferably in spring. Only use brake fluid recommended by us. For further information, refer to “Safe Driving”.

Diesel Fuels

Use only commercially available vehicular diesel fuels No. 2 or No. 1 (ASTM D 975 No. 2-D or No. 1-D).

Change engine oil in compliance with section "Engine Oil Change and Oil Filter Service" if diesel fuels are used whose sulphur content exceeds 0.5% by weight. Marine diesel fuel, heating oil or the like must not be used.

At very low temperatures the fluidity of No. 2-D diesel fuel may become insufficient due to paraffin separation.

To avoid malfunctions, No. 2-D diesel fuel of a lowered cloud point is marketed during the cold season.

If winter diesel fuel is used, there will hardly be any malfunctions at outside temperatures reaching as low as +3° F (−16° C).

Varying with the temperature, add a certain quantity of kerosene, if only No. 2-D summer diesel fuels or

less cold resistant winter diesel fuels are available or if temperatures drop below +3° F (−16° C). If regular gasoline does have to be added, its proportion should not exceed 30%. Premium fuels are not be used.

Engine power may drop according to the proportion of supplementary fuel. For this reason, keep percentage of fuel added to the minimum necessitated by the ambient temperature. Even at ambient temper-

atures of less than −8° F (−22° C) the proportion of supplementary fuel (kerosene) must not exceed 50%.

The following table can be used as a reference, if it becomes necessary to add kerosene to No. 2-D diesel fuel. The mixing ratios shown refer to the total mixture based on No. 2-D summer diesel fuel. We recommend not to exceed the mixture ratio, dependent on prevailing temperatures.

Ambient temperature	No. 2-D Summer diesel fuel %	Supplementary fuel %
+32° F to +14° F (0° C to −10° C)	70	30
+14° F to +5° F (−10° C to −15° C)	50	50

The adding of supplementary fuel to No. 1-D diesel fuel is not recommended even at low ambient temperatures.

Coolants

The coolant is a mixture of water and antifreeze. In production, the cooling system is filled with an antifreeze-water mixture offering protection to approx. -22°F (-30°C). The red mark on the temperature gauge in the instrument cluster is matched to this antifreeze-water mixture (approx. boiling point $257^{\circ}\text{F}/125^{\circ}\text{C}$). The protection against corrosion is also ensured by this mixture making it unnecessary to add a corrosion inhibitor.

The coolant remains in the cooling system all year round and must be renewed after 2 years at the latest. This applies also to trailer operation, hard driving and to vehicles driven in tropical countries.

If coolant has leaked from the cooling system, replace the missing quantity with water and a recommended brand of antifreeze. For normal replenishment (due to evaporation of water) plain water will do.

The water should be clean, soft to medium soft and contain the minimum amount of scale forming minerals (potable water quality).

The coolant mixture should always contain enough antifreeze to ensure protection to a minimum of -4°F (-20°C).

If antifreeze is not available, add a corrosion inhibitor to the cooling water to ensure proper protection against corrosion. To treat the cooling water, do not use more than 1 % (10 cc cm/l) of a recommended corrosion inhibitor.

Without antifreeze in the cooling system, the water already starts boiling at approx. 224°F (118°C), which means that the pointer of the temperature gauge in the instrument cluster may still be below the red mark.

Antifreeze

Prior to the onset of the cold season, check the coolant for its resistance to cold. Repeat this check during the cold spell. Regular testing of the antifreeze concentration is carried out only at each MERCEDES-BENZ maintenance service.

To prevent damage to the cooling system, fill only with recommended brands of antifreeze.

Any MERCEDES-BENZ service station will readily advise you on recommended antifreeze brands.

	240 D	300 D 300 CD
Protection up to	Antifreeze US/Imp. qts. (liter)	
-4°F (-20°C)	3.7/3.1 (3.5 l)	3.7/3.3 (3.75 l)
-22°F (-30°C)	4.7/3.9 (4.5 l)	5.3/4.4 (5.0 l)
-40°F (-40°C)	5.5/4.6 (5.25 l)	6/5.1 (5.75 l)

Customers who are interested in ordering service literature for their vehicles are advised to contact our subsidiaries in the U.S. or Canada at the following addresses, respectively

for U.S.A.: Mercedes-Benz of N.A. Inc.
One Mercedes Drive
P.O. Box 350
Montvale, New Jersey 07645
Att: Technical Publications
Tel: (201) 573-0600

for Canada: Mercedes-Benz of Canada
849 Eglinton Ave., East
Toronto 17, Ont., Canada
Att: Service Department
Tel: 416-425-3550

The above companies will be happy to handle any such requests from customers.

We consider this to be the best way in obtaining accurate information for your vehicle.

Printed in Germany

We reserve the right to modify the technical details of the vehicle as given in the data and illustrations of this Owner's Manual (s.e.e.o.). Reprinting, translation and copying, even of excerpts, is not permitted without our prior authorization in writing.

ZKD / VIII 78 15 / PVL

- **Fuel:** Diesel fuels acc. to ASTM D 975, grades 1 and 2 as well as VV-F-800a grades 1 and 2. Fuel tank capacity approx. 21.1/17.6 US/Imp. gal. (80 l), this includes a 3.0/2.5 US/Imp. gal. (11.5 l) reserve.
- **Engine Oil:** Year-round multigrade oils 10 W-40/10 W-50. For further information, refer to page 81.
Quantity differential between upper and lower dipstick marking level: 3.2/2.6 US/Imp. pts. (1.5 l).
- **Automatic Transmission:** Automatic transmission fluid (ATF). For level checks and replenishment, refer to page 62.
- **Coolant:** For normal replenishment, use water (potable water quality). For further information (e. g. antifreeze), refer to page 86.
- **Bulbs:** High and low beams: Sealed beam, tail and standing lights 10 W (6 cp), turn signal, clearance and side marker lights, front 21/5 W (32/3 cp), turn signal lights, rear 21 W (32 cp), stop lights 21 W (32 cp). For further information, refer to "Technical Data".

- **Tire Pressure:** For driving up to 100 mph (160 km/h)

Cold tires:

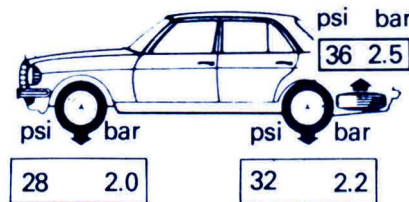

Warm tires:

- after low-speed operation
+ 4 psi (+ 0.3 bar)
- after high-speed operation
+ 8 psi (+ 0.5 bar)



Mercedes-Benz
service

Daimler-Benz AG Stuttgart-Untertuerkheim Zentralkundendienst
123 584 06 97 6500 5060 USA-Ausgabe B 1979